



OPERATING MANUAL

WORK STATION FOR SPRAY GUN CLEANING UW300



UNI-RAM CORPORATION • ONTARIO • CANADA

INTRODUCTION

Uni-ram holds many patents on designs used in its innovative products. Every machine is tested for compliance with Quality Assurance standards. Follow the directions in this manual to operate this machine safely and effectively. Not following these instructions can lead to malfunction or damage to the machine. Follow directions on labels attached to the machine and ensure that the manual is readily available to the operator at all times. If you have any questions about the operation of this machine, call your distributor or a Uni-ram Service Engineer:

North America: Uni-ram Technical Service 1-800-417- 9133

Other Continents: Contact Your Supplier

SETUP

INSPECTION

- Report any transport damage immediately to the carrier and your vendor. Initiate a freight claim with the carrier. The manufacturer is not responsible for freight damage.
- Make sure the bag of accessories contains the following:
- Manual
- Kit-Plug, Guns w. Trigger Lock Springs, 2 pieces (Part No. 140-2340)
- Nozzle Adapters:
 - 110-430 Push-on, conventional systems only
 - 110-430PPS Push-on, disposable cup or conventional systems
- KIT-GCTOOLS Cleaning Tool kit

SPRAY GUN AND CUP

There are 2 nozzle adapters in the accessory bag. If you use a spray gun with a reusable cup, use the nozzle adapter 110-430PPS push-on, the adapter with the holes on the side of the tip of the nozzle adapter. If you use a conventional spray gun system use the nozzle adapter 110-430 or 110-430PPS. Select the one which fits better. The nozzle adapter goes over the nozzle at the bottom of the tank. See the photos in the section, Automatic Cleaning of Spray Guns and Cups.

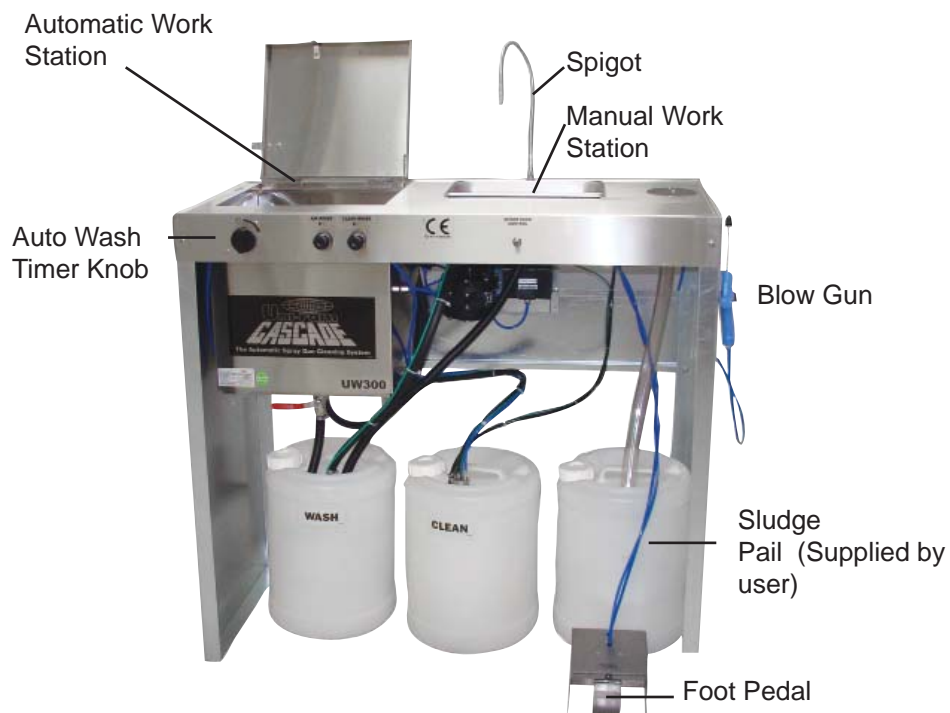

SOLVENTBORNE AND WATERBORNE CLEANING

The UW300 can be used to clean either solventborne or waterborne paint from spray guns but not both types. If you select solventborne cleaning no changes are required. If you choose waterborne cleaning change the auto wash timer so that the timer is set for 3 minutes instead of 1 minutes.

Procedure For 3 Minute Timer

- Note indicator mark is at the top of auto wash timer knob.
- Pull the auto wash timer knob to remove from unit.
- Use pliers to remove the tab (see photo at side).
- Return the tab to the opposite site of center. Make secure.
- Return auto wash timer knob to unit with indicator mark at top.

Auto Wash Timer Knob

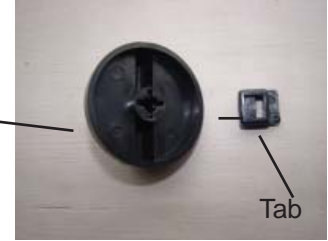

AIR SUPPLY

Remove the cover on the "Air Input" (right side of machine) and attach an air supply adapter (not supplied). The air supply pressure must be at least 85 PSI and the air must be free from contaminants such as water, dust, rust, tar, grease etc.

To prevent damage to the Diaphragm Pump an internal Air Pressure Regulator has been installed to limit the air pressure. Do not install a second air pressure regulator or use a pressure set below 85 PSI.



INSTALL BLOW GUN

The Blow Gun may already be installed. if not, remove the Blow gun from the Accessory Kit bag (inside the tank). Connect the blue line to the Blow Gun and hang it on the bracket (right side).

PAIL SETUP

- The unit is shipped with 2 pails installed. To re-install the pails follow the picture below.
- Move the Drain Valve handle to the "closed" (horizontal) position if it is not already there.
- Two 5-Gal (19 L) pails with liquid are required, one full and one containing 3 gal, full pail on the right ((CLEAN RINSE) and the partially filled pail on the left (WASH).
- The third pail is used to collect used paint. This pail is supplied by the user. .



OPERATION

PRE-CLEAN

- Disconnect the spray gun from the air hose. Pour paint from the cup (when present) into drain on the right hand side of the table. **Note: Make sure the drain has a drain hose and funnel connected to a container (third pail - not supplied with the unit).**
- Rinse cup with liquid and pour into the drain.

AUTOMATIC CLEANING OF SPRAY GUNS AND CUPS

- Loosen the air cap of the spray gun two full turns.
- Lock the trigger in the open position with the Trigger Clamp.
- To prevent liquid from entering the air passgae during automatic cleaning, insert the white plastic Air Passage Plug into the Spray Gun's air inlet. If the air inlet has a male threaded connector instead of a quick connect use the knurled nut attached to the Trigger Clamp (included).
- Place the spray gun so that the cap faces the corner jets. Placement depends on type of spray gun. (See pictures on next page.) Place cup onto the low spray jets and cup holders.

Note on Gravity Feed Spray Gun: Some customers prefer to clean the cup separate from the spray gun.

- Close the lid and turn the "Auto Wash Timer" knob clockwise to start cleaning. In one minute the pump will send 3 gallons (11 L) through the jets and on to the spray gun.
- Push and hold the "Air Rinse" button for about 3 seconds to air-rinse the guns.
- Push and hold the "Clean Rinse" button for about 5 seconds to rinse guns with clean liquid. This will send a pre-set amount of clean liquid (100 cc) through the jets. Wait 30 seconds for the Rinse Pump to fully recharge before repeating.

The liquid flow per clean-rinse cycle is limited to 100 cc to minimize consumption. This quantity is usually sufficient to clean the inside passages of the spray guns.

- To maximize the drying operation, dry the paint channel with the Blow Gun while squeezing the trigger of the spray gun. As a final check for dryness, remove the cap and check it for moisture.

NOTE: THOROUGH DRYING OF THE GUN BOTH INSIDE AND OUT WILL PREVENT CORROSION.

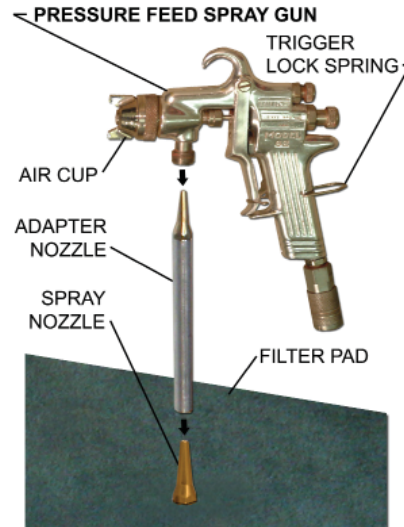
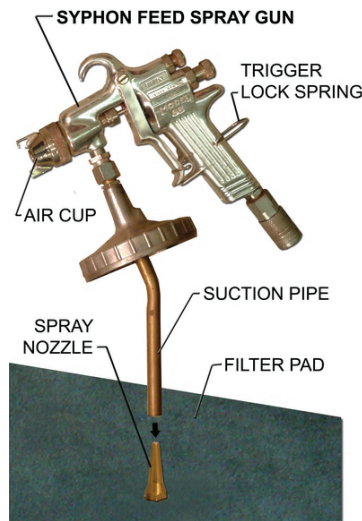
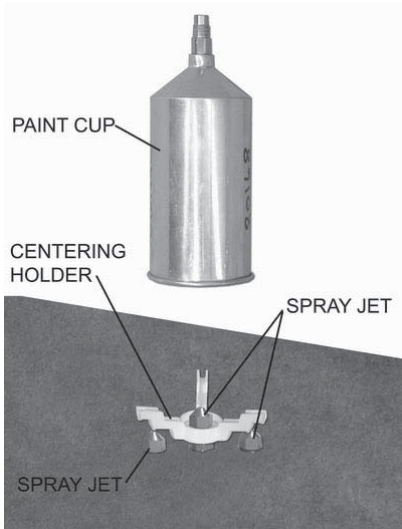

MANUAL CLEANING

Wear gloves and a mask.

- Dissassemble the spray gun and place components in the tray.
- Clean each component. Step on the foot pedal to start the flow of liquid through the spigot and use a cleaning tool (included) to clean the component. Once clean, dry the component with the blow gun and place the component on the table. Reassemble the spray gun when all components are clean.
- Lift the tray and pour the liquid either down the sludge opening if very dirty or pour it down the drain that takes the liquid to the wash pail.
- Use the blow gun to do a final drying of the spray gun. Send air through the air passage way while adjusting the air control dial then send air through the paint passage way while adjusting the dial that

TROUBLESHOOTING

| SYMPTOM | REASON | SOLUTION |
|---|---|--|
| WASH LIQUID DOES NOT FLOW AND PUMP MAKES A HISSING NOISE | <ul style="list-style-type: none"> • Wash pail empty • Paint debris in pump | <p>After Each Step Below, step on the foot pedal. If liquid does not flow, carry out the next step.</p> <ul style="list-style-type: none"> • Check wash water level. • Follow Procedure 1, Blocked Fluid Passage in Diaphragm Pump. |
| WASH LIQUID DOES NOT FLOW AND PUMP MAKES A HISSING NOISE | <ul style="list-style-type: none"> • Water in air line causes pump to stall | <ul style="list-style-type: none"> • Follow Procedure 2, Blockage in Air Passage in Diaphragm Pump |
| WASH LIQUID DOES NOT FLOW AND PUMP DOES NOT MAKE A NOISE | <ul style="list-style-type: none"> • Blockage in air passage • Pump leaks | <ul style="list-style-type: none"> • Follow Procedure 3, Blocked Passage in Air Line • Replace pump |
| PUMP DOES NOT STOP WHEN FOOT REMOVED FROM PEDAL | <ul style="list-style-type: none"> • Air valve stuck | <ul style="list-style-type: none"> • Replace air valve |
| WET FLOOR | <ul style="list-style-type: none"> • Too much liquid in the system • Filter is blocked. | <ul style="list-style-type: none"> • Remove excess liquid (more than 19L) • Clean or replace filter. |

TROUBLESHOOTING PROCEDURES

PROCEDURE 1

Blocked Fluid Passage In Diaphragm Pump

If the pump sounds like it is working but liquid does not flow, clear the fluid passage as follows:

- Remove suction tube from the pail and blow air at 60 PSI into the INLET Solvent Hose (see diagram). Step on foot pedal. This procedure may have to be repeated several times. If this procedure does not help, blow some liquid into the suction hose using a spray gun, wait one minute and step on foot pedal. This procedure may have to be repeated several times. If this procedure does not work, the pump must be replaced.

If you need to replace the pump call your local dealer. The warranty on the diaphragm pump is two years from date of purchase.

This procedure will also clear a blockage in the fluid line for the wash gun.



UDP2TAB

PROCEDURE 2

Blocked Air Passage In Diaphragm Pump

If there is a steady hissing sound and the pump is not cycling, the spool valve has stalled due to a blocked air passage. Follow the procedure below to clear the blockage.

- Connect a blow gun to an 60 PSI source. Locate the blue hose that extends from the air exhaust port of the diaphragm pump. Use a blow gun to blow air into the open end of this hose. Turn timer. If the procedure is successful, the pump will start working. The procedure may have to be repeated several times. If this procedure does not work, replace the pump.
- **Cause:** Contaminants in the air supply (water, oil, solid particles etc)
- **Preventative Action:** If necessary, install an Airline (Moisture) Filter.



UDP4TA

PROCEDURE 3

Blocked Passage in Air Line

The components in the air line are the **diaphragm pump, air valve and regulator.**

To troubleshoot a component:

- 1) Disconnect the air line to the component using the quick disconnect.
- 2) Step on foot pedal and check for presence of positive air pressure in the air line. If there is ample positive air pressure, replace the component.

If air pressure is absent, there is a faulty component upstream. Reconnect the air line and check the operation of the next component upstream by following steps 1 and 2 above.

FLOW DIAGRAM

Use the diagram to trace the flow of compressed air and liquid.

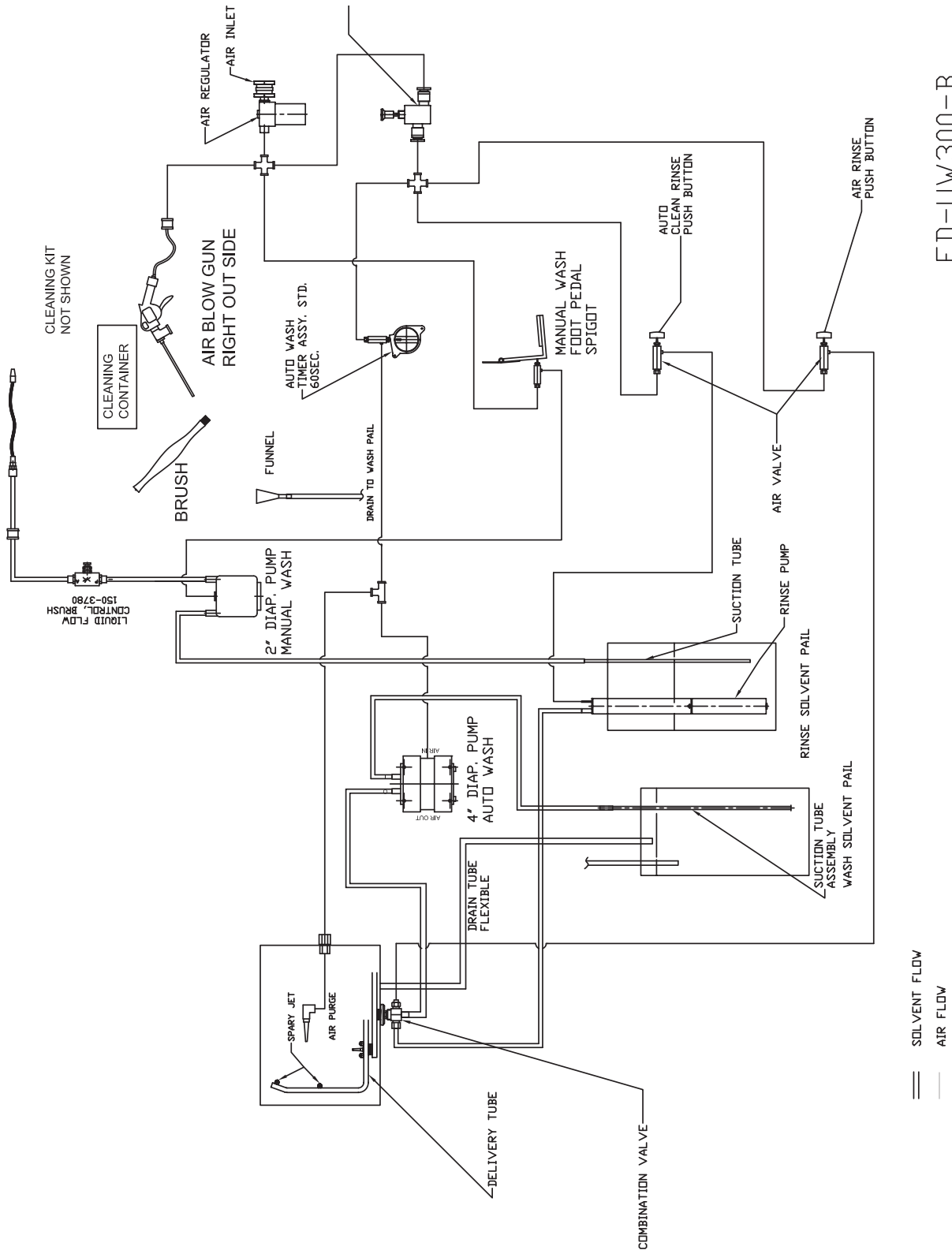

FD-UW300-B

DATE:2015-10-14

REPLACEMENT PARTS

| DESCRIPTION | Part Number |
|------------------------------------|--------------------|
| 2" DIAPHRAGM PUMP | UDP2TAB |
| 4" DIAPHRAGM PUMP | UDP4TA |
| AIR BLOW GUN | 102-7010 |
| TIMER KIT | 115-200/K |
| PEDAL VALVE | 115-400BF |
| PEDAL VALVE, COMPLETE ASSEMBLY | 780-4300 |
| NOZZLE EXTENSION, REGULAR, PUSH-ON | 110-430 |
| NOZZLE EXTENSION, PPS, PUSH-ON | 110-430PPS |
| NOZZLE EXTENSION, PPS, THREADED | 780-3530 |
| TRIGGER CLAMP & PLUG KIT | 140-2340 |
| AIR SUPPLY PLUG WITH TUBE | 140-230 |
| "CLEAN" PAIL (RINSE) | 780-8111P |
| "WASH" PAIL (3 HOLES) | 780-8114P3 |



Full Product Warranty

These Uni-ram products have been engineered and manufactured to high performance standards. Each unit has been subjected to detailed factory testing before shipment.

This product comes with a one-year full warranty from the date of purchase. Uni-ram Corporation reserves the right to repair or replace the unit, free of charge, to the original purchaser if a part is found to be defective in material or workmanship as determined by factory service personnel. The items listed below under "Conditions of Warranty" as consumables are not covered.

Uni-ram reserves the right to direct the customer to ship the unit collect to the Uni-ram factory or to an approved Service Center for repair using the Uni-ram Return Goods Procedure or to repair the unit on-site. To prevent damage in transport, the purchaser must ship the unit in the original packaging or use alternate adequate packaging. All units must be **shipped clean and free of solvent**.

Diaphragm Pump:

We are pleased to advise that the warranty on the diaphragm pump, the heart of the spray gun cleaner, comes with a 2 year replacement warranty. If, in the unlikely event your diaphragm pump fails during the first two years of service, call Uni-ram Service at 1-800-417-9133. We will send you a new pump free of charge and arrange for the return of your original pump.

Conditions of Warranty:

As Uni-ram Corporation has no control over the working conditions or circumstances under which the purchaser stores, handles or uses the product, Uni-ram makes no warranty or claim, either expressed or implied with respect to this product's fitness for any purpose or the result to be obtained from its use. This condition applies to the sale of all products and no representative or distributor of Uni-ram Corporation has the authority to waive or change these conditions.

This warranty applies only to the original purchaser and does not apply if the unit has been mis-used, overloaded, neglected, altered or used for any purpose other than those specified in the operating and installation instructions. Deterioration due to normal wear is not covered by this warranty. Damage due to accident, transportation, fire, floods or acts of God is also not covered. Units whose serial numbers have been altered or removed are not covered. The warranty is invalid if unauthorized chemicals as noted in the manual or solvents with acid content are used in this unit. Unauthorized attempts at self-repair or alterations by the owner also invalidate this warranty. Interior or exterior finishes are not covered by this warranty.

Consumable Items are not covered by this warranty (eg: gaskets, screens, bags, filters, nozzles and air jets).

This warranty replaces all other warranties expressed or implied by statute or otherwise.

To make a claim, call Uni-ram Service at 1-800-417-9133 and quote the serial number of the unit.