

Master Fuel Injection Test Kit

Stock Number W89726

OWNER'S MANUAL



FOR YOUR SAFETY,
please read these instructions carefully and retain them for future use.

PRODUCT SPECIFICATIONS

Product Features

Allows for accurate and quick diagnoses of fuel intake issues.
Compatible with most domestic and import cars.
Includes all necessary adapter clamps and hoses.
Quick, convenient hook ups.

Material Brass / Steel / Aluminum / Polyurethane / Rubber / Vinyl / Thermoplastic

Contents Fuel Gauge w/Quick Release Valve / Seven Various Hose Assemblies
Four Metric Paired Hose Adapters / Two Steel Hose Clamps
Four Copper Washers / Fifteen Metric Sized Fittings / 8 SAE Sized Fittings

SAVE THIS MANUAL

You will need this manual for the safety warnings and precautions, assembly, operating, inspection, maintenance and cleaning procedures, parts list and assembly diagram. Keep your invoice with this manual. Write the invoice number on the inside of the front cover. Keep this manual and invoice in a safe and dry place for future reference.

GENERAL SAFETY RULES

IMPORTANT SAFETY INSTRUCTIONS

READ AND UNDERSTAND ALL INSTRUCTIONS

Failure to follow all instructions detailed in this manual may result in serious personal injury.

SAVE THESE INSTRUCTIONS

1. Keep your work area clean and well lit. Cluttered and dark work areas invite accidents.
2. Stay alert. Watch what you are doing, and use common sense when operating tools and equipment. Do not assemble or use this product while tired or under the influence of drugs, alcohol, or medication. A moment of inattention while operating tools and equipment may result in serious personal injury.
3. Wear eye protection. Wear ANSI-approved safety impact glasses and full face shield when using this product.
4. Do not force the Pressure Test Kit. Use the correct product for your application. The correct product will do the job better and safer at the rate for which it is designed.
5. Maintain the Pressure Test Kit with care. Keep this product clean. Properly maintained products are less likely to malfunction. Do not use damaged products. Tag damaged products "Do not use" until repaired.
6. Check for any condition that may negatively affect the Pressure Test Kit's operation. If readings are inconsistent, or if it appears that the fuel gauge is not functioning properly, the Test Kit should be serviced by a qualified service technician. Many accidents are caused by poorly maintained products.
7. Use only accessories that are recommended by the manufacturer for your model. Accessories that may be suitable for one product may become hazardous when used on another product.
8. Industrial applications must follow OSHA requirements.
9. Maintain labels and nameplates on the Pressure Test Kit. These carry important information. If unreadable or missing, contact Harbor Freight Tools for a replacement.
10. Use the right product for the job. There are certain applications for which this product was designed. Do not use small products to do the work of larger industrial products. Do not use this product for a purpose for which it was not intended.
11. Product service must be performed only by qualified service technician. Service or maintenance performed by unqualified personnel could result in a risk of injury.
12. When servicing the Pressure Test Kit, use only identical replacement parts. Follow instructions in the "Inspection, Maintenance, And Cleaning" section of this manual.

INSPECTION, MAINTENANCE AND CLEANING

CAUTION! Make sure to wear ANSI-approved safety impact goggles before performing any inspection, maintenance, or cleaning of Pressure Test Kit.

Before each use: Inspect the general condition of the Pressure Test Kit. Check for damaged parts, and any other condition that may affect this product's safe operation. If a problem occurs, have the problem corrected before further use. Do not use damaged equipment. To clean: Use a clean, soft, damp cloth, and mild detergent. Then, allow to air dry. Do not use solvents.

CAUTION! All maintenance, service, and repairs not discussed in this manual should only be performed by a qualified service technician.

Use of unauthorized parts or failure to follow maintenance instructions may create a risk of personal injury.

13. Always make sure the area of use for this product is clear of any children. Do not allow children to play with this product.
14. Do not allow the vehicle's engine to run while using the Pressure Test Kit. When running, the engine of a vehicle produces carbon monoxide, a colorless, odorless, toxic gas that, when inhaled, can cause serious personal injury or death.
15. Prior to using this product, make sure to read and understand all instructions and safety precautions as outlined in the vehicle manufacturer's manual.
16. Always keep hands and fingers away from the moving parts and hot parts of an engine.
17. Do not use this Pressure Test Kit on diesel fuel systems.
18. Do not smoke while performing any fuel injection tests or repairs.
19. Always have a dry chemical (Class B) fire extinguisher within reach.
20. Make sure to provide a suitable container to catch released fuel when the system is de-pressurized.
21. Take extra care to prevent fuel from contacting hot engine parts. It is recommended that tests be performed when the engine is cold.
22. If a drop light is used, do not allow fuel to contact the hot surface of the bulb.
23. Never remove any fittings with the engine running.
24. Never loosen any fittings or attempt to remove hoses of vehicle or Pressure Test Kit until you have relieved the fuel system pressure. Refer to the vehicle manufacturer's service manual for specific fuel pressure relief procedures.
25. Always check all connections for leaks during the testing procedure. At any sign of leaks, turn off the engine or disable the fuel pump. Clean up any spilled fuel and repair all leaks before resuming test. When preparing for pressure testing, make sure the vehicle's transmission is placed in "PARK" or "NEUTRAL" and the emergency brake is applied.
26. When the test is complete, de-pressurize the system and remove the Pressure Test Kit. Re-assemble the vehicle's fuel line(s) to its original condition. Start the engine and check for leaks. If any leaks are present, stop the engine, relieve fuel pressure and repair all leaks.
27. **WARNING:** The brass components of this product contain lead, a chemical known to the State of California to cause birth defects (or other reproductive harm). (California Health & Safety code § 25249.5, et seq.)
28. People with pacemakers should consult their physician(s) before use. Electromagnetic fields in close proximity to heart pacemaker could cause pacemaker interference or pacemaker failure.
Caution is necessary when near coil, spark plug cables, or distributor of running engine. Engine should be off during distributor adjustment.
29. The warnings and cautions discussed in this manual cannot cover all possible conditions and situations that may occur. It must be understood by the operator that common sense and caution are factors which cannot be built into this product, but must be supplied by the operator.

UNPACKING

When unpacking, check to make sure all the parts shown in the Parts List on page 20 are included. If any parts are missing or broken, please call 1-800-497-0552.

Before each use: Inspect the general condition of the Pressure Test Kit. Check for damaged parts, and any other condition that may affect this product's safe operation. If a problem occurs, have the problem corrected before further use. Do not use damaged equipment.

CAUTION! All maintenance, service, and repairs not discussed in this manual should only be performed by a qualified service technician.

APPLICATIONS

#	IMAGE	DESCRIPTION	APPLICATION
1		Basic Gauge with boot and Hook - 100 P.S.I.	Connects to #8 for basic testing
2		General Motors 2.5L & 5.7L (Non Multi-port)	For vehicles with quick connect fuel filters such as 2.5L Oldsmobile Clera 1989 & up, and 5.7L Chevrolet Caprice 1991 & up
3		General Motors 2.2L (Non Multi-port)	1992 & up: Chevrolet Cavalier, Pontiac Sunbird, Buick Skylark and Quad 4 equipped Pontiac Grand Am
4		Hose Clamps and Connection Hoses	For use in making certain hook up connections
5		General Motors Throttle Body Injection (TBI)	In line Adapter - Replaces fuel filter with threads on both ends
6		Parts	Seals, Tank Valve and Gasket
7		Double End Barbed Hose Adapter	When vehicle requires testing by splicing into 1/4, 5/16 or 3/8 in. Fuel line hose
8		Single End Barbed Hose Adapter	All vehicles requiring end of line testing with 1/4, 5/16 or 3/8 in. Fuel line hose
9		Honda, Acura and Sterling Multi-Port (PGM-FI)	For vehicles with 6mm - 1.00 fittings
10 - 14		Asian and European vehicles with Multi-Port & Boach AFC	For vehicles with 8mm - 1.00, 10mm - 1.00, 12mm - 1.25, 12mm - 1.50 & 14mm - 1.5 Banjo Bolts
15 - 24		E & K Jetronic Systems/CISE	Tests CIS (Continuous Injection Systems) found on European cars and Volkswagon models assembled in the U.S. For vehicles with metric threads/Tests CISE (Constant Injection System Electronic) found on European cars with metric threads
25		Pressure Testing and Bleed-off Assembly	For use in performing tests with Basic Gauge (1) and Adapters
26		Ford-Multi-Port (EFI)	For smaller Schrader valves
27		General Motors, Chrysler & Imports with 7/16 in. - 20 threaded test port	For Larger Schrader valves on Multi-Port vehicles
28		Ford CFI	For 5/16 in. hair pin connections
29		General Motors and Chrysler inline Adapter	In line Adapter for vehicles with 3/8 in. hair pins
30		Ford EFI	For Spring Lock Fittings
31		CIS Testing Assembly with Ball Valve	For use in testing with Basic Gauge (1), Pressure Testing, and Bleed-off Assembly (25) and Adapters

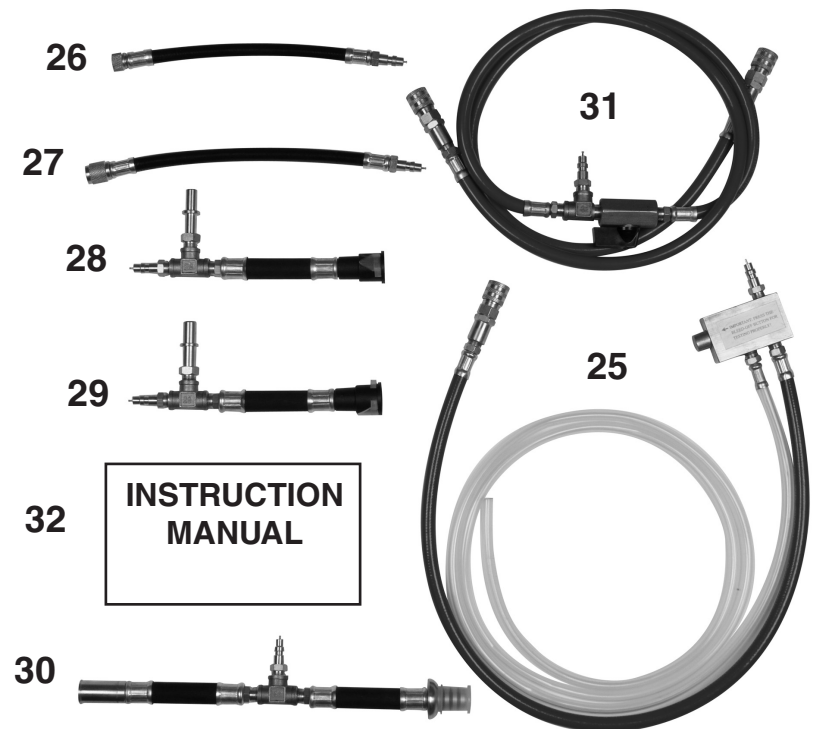
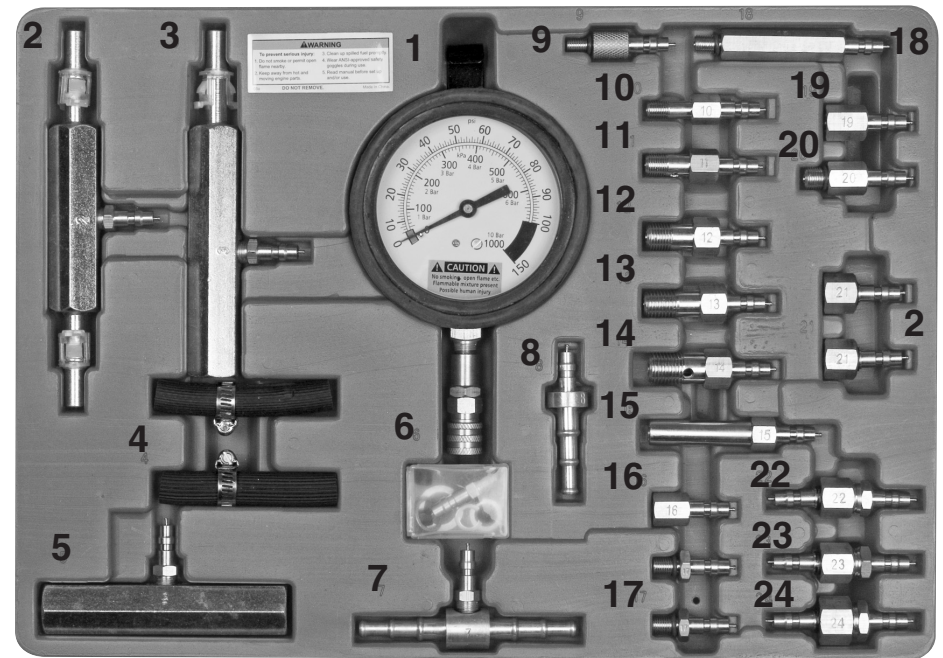

PLEASE READ THE FOLLOWING CAREFULLY
THE MANUFACTURER AND/OR DISTRIBUTOR HAS PROVIDED THE PARTS LIST AND ASSEMBLY DIAGRAM IN THIS MANUAL AS A REFERENCE TOOL ONLY. NEITHER THE MANUFACTURER OR DISTRIBUTOR MAKES ANY REPRESENTATION OR WARRANTY OF ANY KIND TO THE BUYER THAT HE OR SHE IS QUALIFIED TO REPLACE ANY PARTS OF THE PRODUCT. IN FACT, THE MANUFACTURER AND/OR DISTRIBUTOR EXPRESSLY STATES THAT ALL REPAIRS AND PARTS REPLACEMENTS SHOULD BE UNDERTAKEN BY CERTIFIED AND LICENSED TECHNICIANS, AND NOT BY THE BUYER. THE BUYER ASSUMES ALL RISKS AND LIABILITY ARISING OUT OF HIS OR HER REPAIRS TO THE ORIGINAL PRODUCT OR REPLACEMENT PARTS THERETO, OR ARISING OUT OF HIS OR HER INSTALLATION OF REPLACEMENT PARTS THERETO.

PARTS LIST

PART	DESCRIPTION
1	0-100 PSI (0-7.0 Bar) Gauge w/Boot & Hang-Up Hook
2	GM 2.5L & 5.7L Fuel Injection Pressure Test Adapter
3	GM 2.2L Fuel Injection Pressure Test Adapter
4	Hose Clamps & Hoses
5	GM Throttle Body Injection (TBI) Fuel Pressure Adapter
6	Seals, Tank Valve & Gasket
7	Double End Barbed Hose Adapter
8	Single End Barbed Hose Adapter
9	6mm-1.00 Honda & Acura Multi-Port (PGM-FI) Adapter
10	8mm - 1.00 Banjo Bolt Adapter
11	10mm - 1.00 Banjo Bolt Adapter
12	12mm - 1.25 Banjo Bolt Adapter
13	12mm - 1.50 Banjo Bolt Adapter
14	14mm - 1.50 Banjo Bolt Adapter
15	8mm - 1.00 Long Adapter
16	8mm - 1.00 Female Adapter
17	8mm - 1.00 Male Adapter with O-Ring
18	8mm - 1.00 Male Adapter (Long)
19	10mm - 1.00 Female Adapter
20	10mm - 1.00 Male Adapter
21	12mm-1.50 Female Swivel Adapter
22	14mm-1.50 Male & Female Swivel Adapter
23	1/4" BSPT Male & Female Swivel Adapter
24	16mm-1.50 Male & Female Swivel Adapter
25	Pressure Testing & Bleed-Off Assy.
26	Small Schrader Valve Test Adapter for Ford
27	Large Schrader Valve Test Adapter for GM & Chrysler
28	5/16" Hair Pin Adapter for Ford CFI
29	3/8" Hair Pin Adapter for GM & Chrysler
30	Spring Lock Adapter for Ford EFI
31	CIS Testing Assy. w/Ball Valve
32	Instruction Manual
33	Carrying Case (Not Shown)

NOTE:

Some parts are listed and shown for illustration purposes only, and are not available individually as replacement parts.

TYPICAL HOOK-UPS

Note: Prior to using this product, make sure to read and understand all instructions and safety precautions as outlined in the vehicle manufacturer's manual.

GM Multi-Port And Chrysler Multi-Port - FIGURE A:

1. Turn off ignition.
2. Relieve the fuel pressure. Refer to the vehicle's service manual for specific pressure relief procedures.
3. Connect the Gauge (1) to the Pressure Testing and Bleed-off Assembly (25).
4. Remove the protective cap from test fitting on vehicle.
5. Attach the swivel female fitting on the Adapter (27) to the test fitting on the vehicle. Hand tighten.
6. Attach the female quick coupler on the Pressure Testing and Bleed-off Assembly (25) to the male quick connector on the Adapter (27).
7. Start the engine and allow it to idle. Check for leaks.
8. Read the Gauge (1) and compare result with the pressure in service manual.
9. Stop engine and turn ignition OFF.
10. With free end of Bleed-off Hose in suitable container, press the Button on side of bleed-off assembly slowly to de-pressurize the fuel system.
11. Refer to the General Safety Rules section before removing Tester from vehicle.
12. Replace the protective cap onto the test fitting on vehicle. Check for leaks.

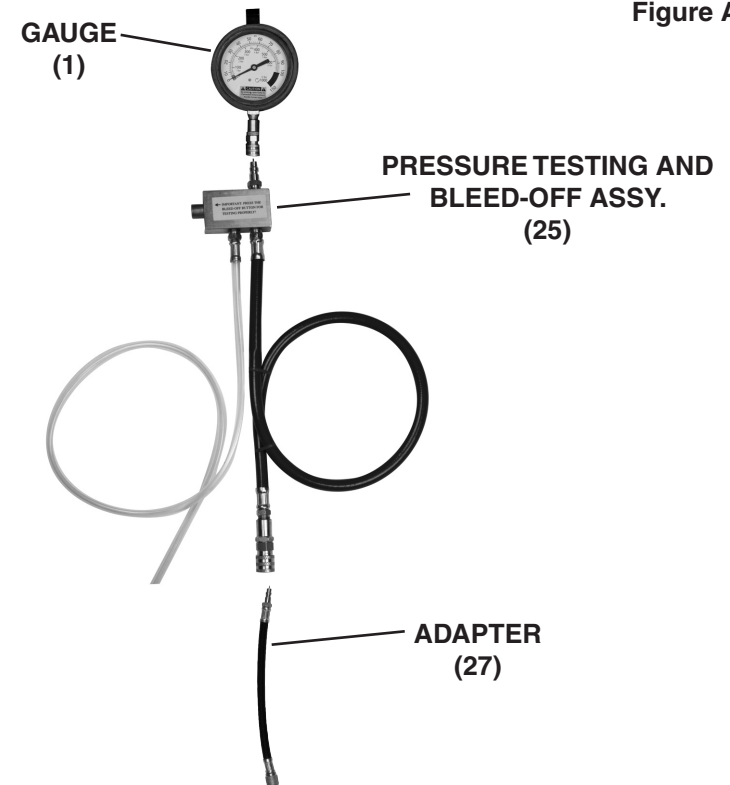
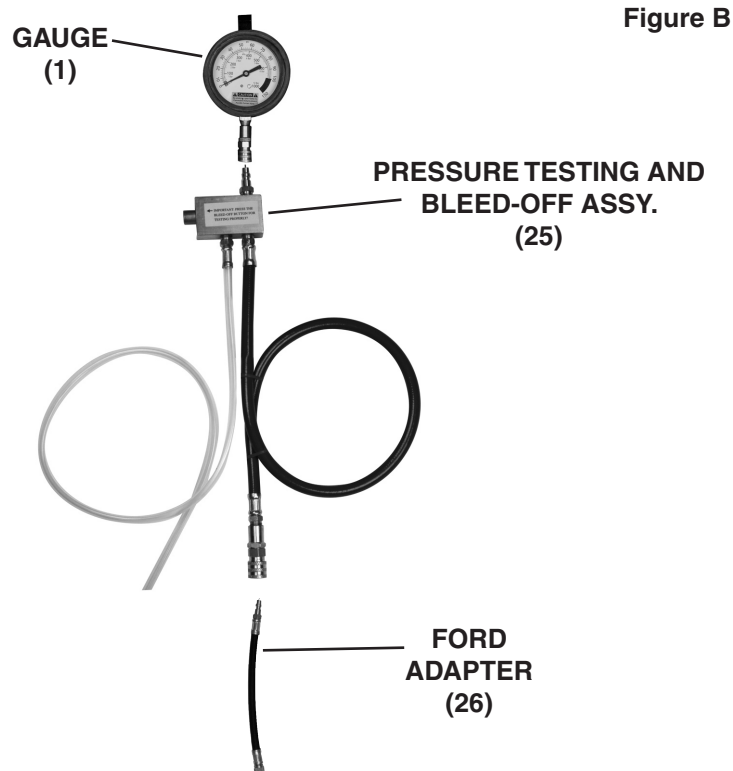

Figure A

Ford Multi-Port (EFI) - FIGURE B:

1. Turn off ignition.
2. Relieve the fuel pressure. Refer to the vehicle's service manual for specific pressure relief procedures.
3. If the vehicle has multi-port fuel injection, the test valve is located on the fuel rail. Remove the protective cap from the test valve.
4. Connect the Gauge (1) to the Pressure Testing and Bleed-off Assembly (25).
5. Attach the female end of Ford Adapter (26) to test the valve. Hand tighten.
6. Attach the female quick coupler on the Pressure Testing and Bleed-off Assembly (25) to the male quick coupler on the Ford Adapter (26).
7. Start the engine and allow it to idle. Check for leaks.
8. Read the Gauge (1) and compare result with pressure in service manual.
9. Stop the engine and turn the ignition OFF.
10. With free end of bleed-off hose in suitable container, press the button on side of bleed-off assembly slowly to de-pressurize the fuel system.
11. Refer to the General Safety Rules section before removing Tester from vehicle.
12. Replace the protective cap onto the test fitting on vehicle. Check for leaks.



Constant Injection System Electronic (CISE) - European Vehicles - FIGURE O:

1. Turn off ignition.
2. Clean the top of the fuel distributor to keep dirt from entering the fuel system.
3. Relieve the fuel pressure. Refer to the vehicle's service manual for specific pressure relief procedures.
4. The CIS system has a primary circuit with pressure regulated at the fuel distributor. This is known as supply pressure, primary pressure, or line pressure. The side of the tester without the ball valve is connected to this circuit. The other circuit is known as the control circuit. This contains the control pressure regulator, known as the warm-up compensator. The side of the test with the ball valve is connected to this circuit.
5. Connect the Gauge (1) to the Pressure Testing and Bleed-off Assembly (25).
6. Install Adapter(s) (10, 11, 12, 13, 15, 16, 18, 19, 20, 21, 22, 23, or 24) and "O-Ring" to the engine as required. Hand tighten only. Then connect Hoses to Adapters.
7. Attach the female quick coupler on the Pressure Testing and Bleed-off Assembly (1) to the male quick coupler on the CIS Testing Assembly with Ball Valve (31). With free end of bleed-off hose in a suitable container, press button on side of bleed-off assembly slowly to release any air in the test Hose.
8. Refer to the General Safety Rules section before removing tester from vehicle. Remove tester and Adapters from vehicle. Reconnect vehicle's fuel injection lines to original condition. Start the vehicle and check for leaks.
9. Start the engine and check for leaks. Read the fuel pressure. Compare the value on the Gauge (1) to the value in the service manual.

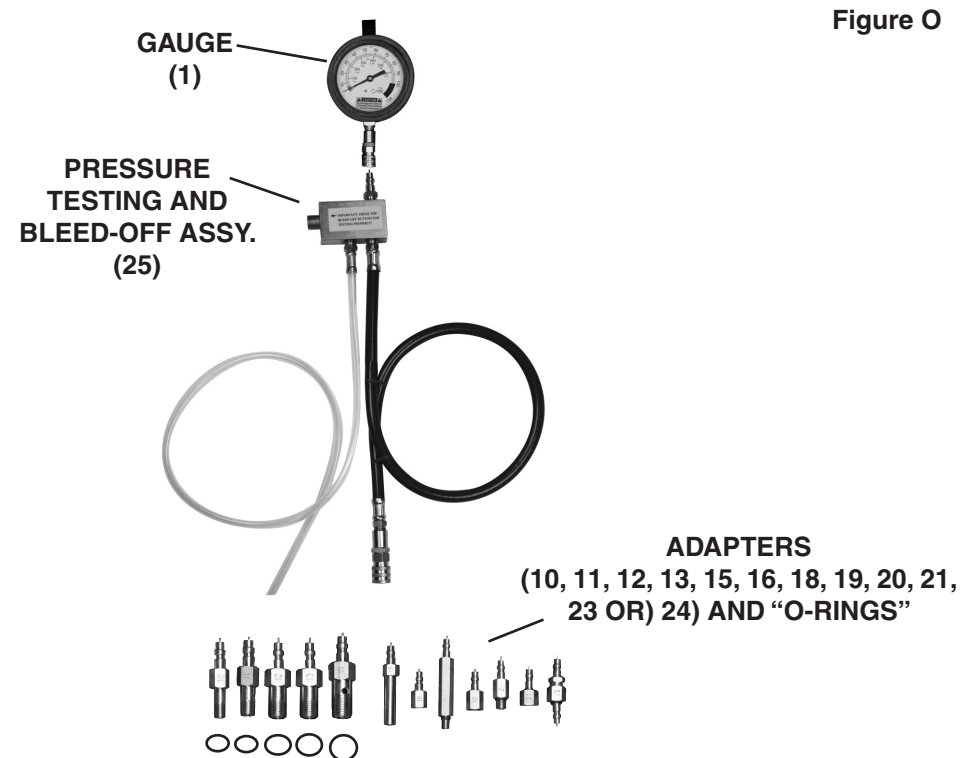

Bosch Continuous Injection System (CIS) Testing - FIGURE N:

1. Turn off ignition.
2. Clean the top of the fuel distributor to keep dirt from entering the fuel system.
3. Relieve the fuel pressure. Refer to the vehicle's service manual for specific pressure relief procedures.
4. The CIS system has a primary circuit with pressure regulated at the fuel distributor. This is known as supply pressure, primary pressure, or line pressure. The side of the tester without the ball valve is connected to this circuit. The other circuit is known as the control circuit. This contains the control pressure regulator, known as the warm-up compensator. The side of the test with the ball valve is connected to this circuit.
5. Connect the Gauge (1) to the Pressure Testing and Bleed-off Assembly (25).
6. Install Adapter(s) (10, 11, 12, 13, 15, 16, 18, 19, 20, 21, 22, 23, or 24) and "O-Ring" to the engine as required. Hand tighten only. Then connect Hoses to Adapters.
7. Attach the female quick coupler on the Pressure Testing and Bleed-off Assembly (1) to the male quick coupler on the CIS Testing Assembly with Ball Valve (31). With free end of bleed-off hose in a suitable container, press button on side of bleed-off assembly slowly to release any air in the test Hose.
8. Refer to the General Safety Rules section before removing tester from vehicle. Remove tester and Adapters from vehicle. Reconnect vehicle's fuel injection lines to original condition. Start the vehicle and check for leaks.
9. Start the engine and check for leaks. Read the fuel pressure. Compare the value on the Gauge (1) to the value in the service manual.

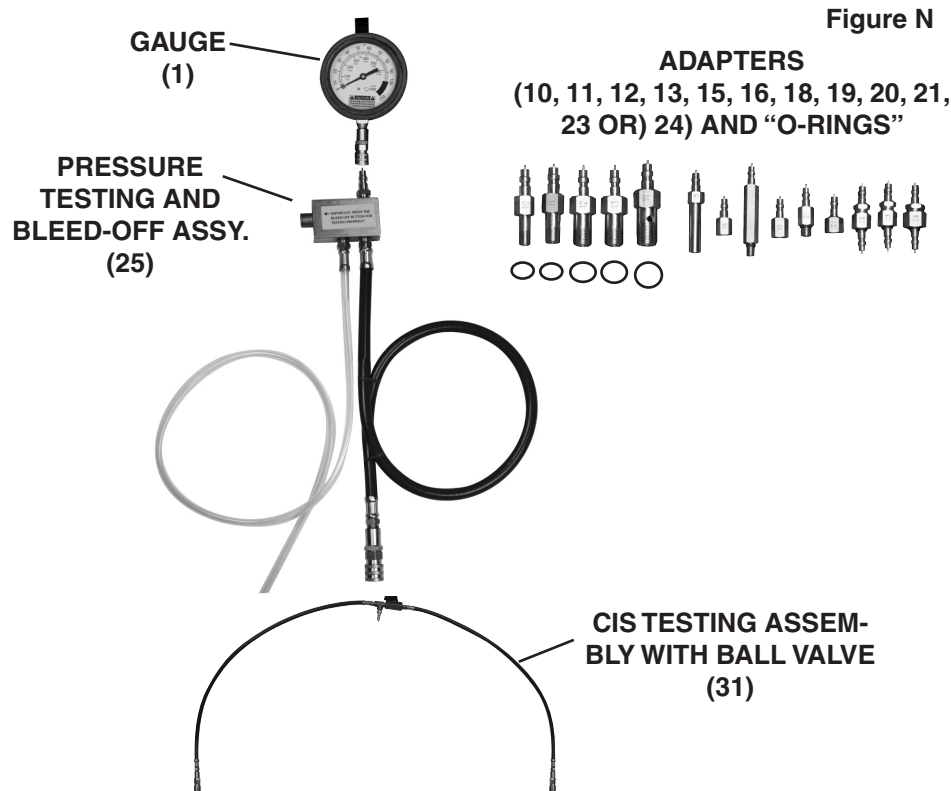

Asian And European Multi-Port Vehicles (Bosch AFC) - FIGURE C:

1. Turn off ignition.
 2. Relieve the fuel pressure. Refer to the vehicle's service manual for specific pressure relief procedures.
 3. The pressure test connection for these vehicles is located at the point where the fuel inlet meets the fuel rail or cold start injector. The fuel inlet is secured to the fuel rail of cold start injector by a banjo fitting.
 4. Remove the banjo fitting that secures the fuel inlet to the fuel rail or cold start injector. Place a shop cloth around the bolt to catch any spilled fuel.
 5. Install one of the five pressure test Adapters (10, 11, 12, 13, 14) with the corresponding sealing washer and one of the gaskets from the banjo fitting so that the fuel inlet is once again connected to the fuel rail or cold start injector. The test Adapter will hold the banjo assembly in position.
 6. Torque the Adapters (10, 11, 12, 13, 14) to the following specifications:
- | Adapter # | Size | Torque Specifications |
|-----------|-------------|-----------------------|
| 10 | 8mm - 1.00 | 48in/lb. (5.5 N-m) |
| 11 | 10mm - 1.00 | 72in/lb. (8.0 N-m) |
| 12 | 12mm - 1.25 | 96in/lb. (11.0 N-m) |
| 13 | 12mm - 1.50 | 96in/lb. (11.0 N-m) |
| 14 | 14mm - 1.50 | 125in/lb. (14.0 N-m) |
7. Connect the Gauge (1) to the Pressure Testing and Bleed-off Assembly (25).
 8. Attach the female quick coupler on the Pressure Testing and Bleed-off Assembly to the male quick coupler on the test Adapter.
 9. Start the engine and allow it to idle. Check for leaks.
 10. Read the Gauge (1) and compare the result with pressure in the service manual.
 11. Stop the engine and turn the ignition OFF.
 12. With free end of bleed-off hose in a suitable container, press the button on side of bleed-off assembly slowly to de-pressurize the fuel system.
 13. Refer to the General Safety Rules section before removing Tester from vehicle.
 14. Remove the Tester and the pressure test Adapter.
 15. Re-assemble the banjo fitting to the fuel inlet and fuel rail (or cold start injector). New Gaskets (6) should be used when re-assembling fuel lines. Check for leaks.

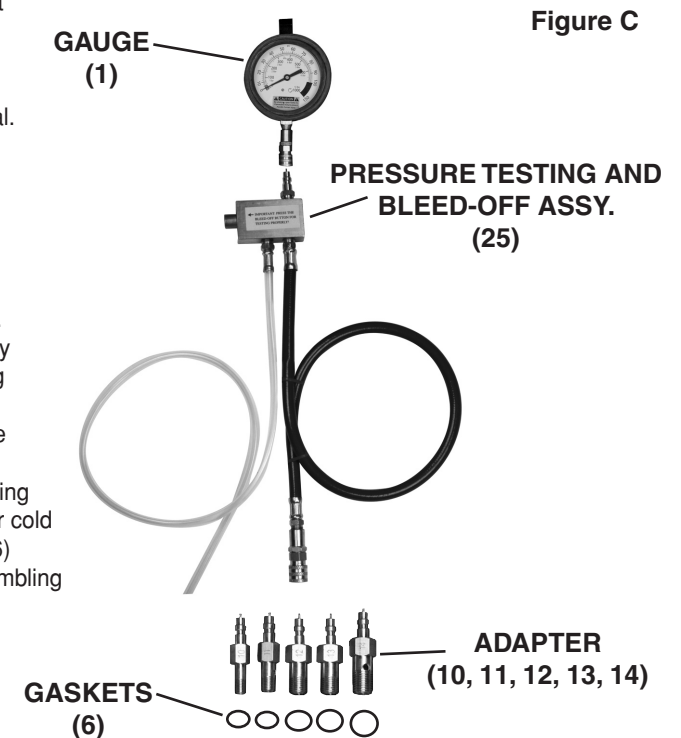

GM Throttle Body Injection (TBI) With Fuel Filter Threaded On Both Sides - FIGURE D:

1. Turn off ignition.
2. Relieve the fuel pressure. Refer to the vehicle's service manual for specific pressure relief procedures.
3. Locate the fuel filter on the vehicle.
4. Remove the fuel filter by unscrewing the fuel lines from both ends of the fuel filter. Use a container to catch any fuel that may spill out. Wipe off excess fuel that may spill on the vehicle.
5. Install the GM TBI Adapter (5) in place of the fuel filter by threading each fuel line into either end of the Adapter. Do not overtighten.
6. Connect the Gauge (1) to the Pressure Testing and Bleed-off Assembly (25).
7. Attach the female quick coupler on the Pressure Testing and Bleed-off Assembly to the male quick coupler on the GM TBI Adapter (5).
8. Start the engine and check for leaks. Read the fuel pressure. Compare the value on the Gauge (1) to the value in the service manual.
9. Stop the engine and turn the ignition OFF.
10. With free end of bleed-off hose in a suitable container, press the button on side of bleed-off assembly slowly to de-pressurize the fuel system.
11. Refer to the General Safety Rules section before removing Tester from vehicle.
12. Remove the fuel pressure Adapter following the above instructions for removing the fuel filter.
13. Re-install the fuel filter. Start the vehicle and check for leaks.

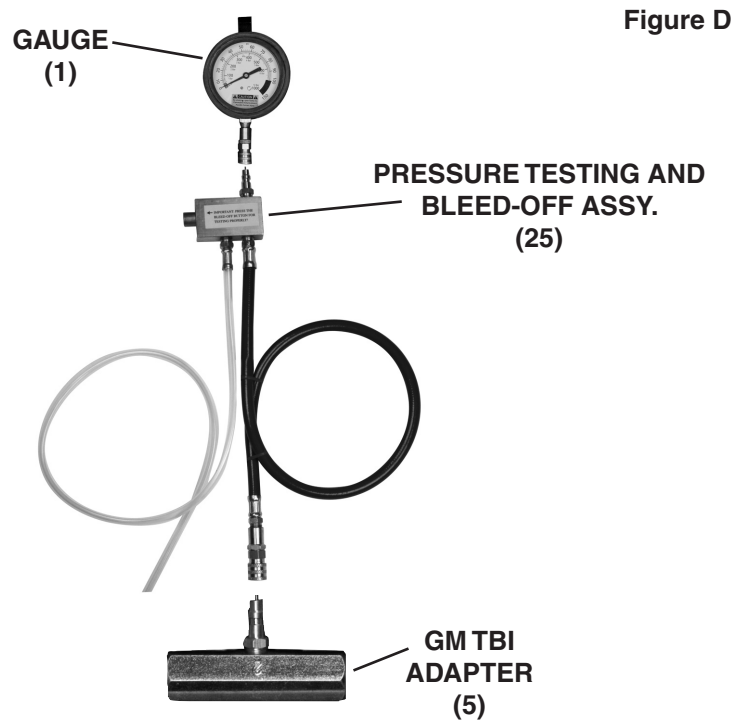

Figure D

Chrysler Throttle Body Injection - FIGURE M:

1. Turn off ignition.
2. Relieve the fuel pressure. Refer to the vehicle's service manual for specific pressure relief procedures.
3. Loosen the hose clamp and disconnect the fuel line hose from the inlet side of the vehicle's throttle body.
4. Confirm if the size of the inlet fuel line hose is 1/4" or 5/16".
5. Assemble the correct Hose (4) and Hose Clamps (4) onto the Double End Barbed Adapter (7).
6. Connect the Adapter assembly between the disconnected fuel line and the throttle body inlet nipple on the vehicle. Tighten all Hose Clamps (4) securely.
7. Connect the Gauge (1) to the Pressure Testing and Bleed-off Assembly (25). Attach the female quick coupler on the Pressure Testing and Bleed-off Assembly (25) to the male quick coupler on the Adapter (7).
8. Start the engine and allow it to idle. Check all connections for leaks. Read the Gauge (1) and compare the result with the pressure values in the service manual.
9. Stop the engine and turn the ignition OFF.
10. With free end of bleed-off hose in a suitable container, press button on side of bleed-off assembly slowly to de-pressurize the fuel system. Refer to General Safety Rules section before removing tester from vehicle.
11. Reconnect vehicle's fuel line and tighten all clamps securely. Check all connections for leaks.

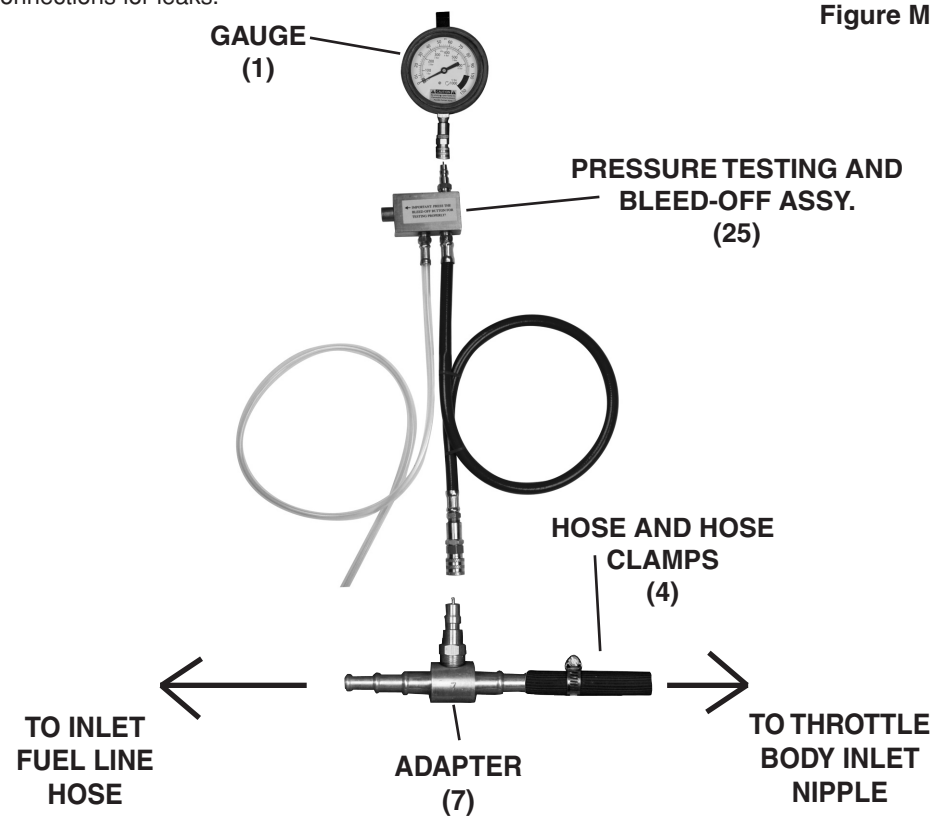
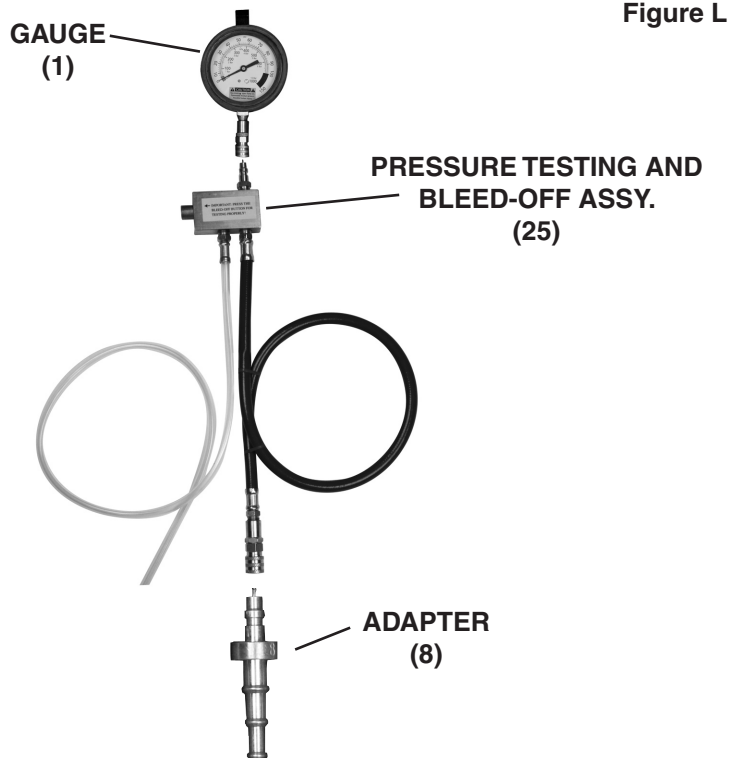

Figure M

All Vehicles Requiring End Of Line Testing With 1/4", 5/16", Or 3/8" Fuel Line Hose - FIGURE L:

1. Turn off ignition.
2. Relieve the fuel pressure. Refer to the vehicle's service manual for specific pressure relief procedures.
3. Loosen the hose clamp and disconnect the fuel line.
4. Install the Single End Barbed Hose Adapter (8) into the fuel supply hose. Tighten hose clamp securely.
5. Connect the Gauge (1) to the Pressure Testing and Bleed-off Assembly (25).
6. Attach the female quick coupler on the Pressure Testing and Bleed-off Assembly (25) to the male quick coupler on the Adapter (8).
7. Start the engine and allow it to idle. Check all connections for leaks. Read the Gauge (1) and compare the result with the pressure values in the service manual.
8. Stop the engine and turn the ignition OFF.
9. With free end of bleed-off hose in a suitable container, press button on side of bleed-off assembly slowly to de-pressurize the fuel system. Refer to General Safety Rules section before removing tester from vehicle.
10. Reconnect vehicle's fuel line and tighten all clamps securely. Check all connections for leaks.



GM Throttle Body Injection (TBI) With Quick Connect Fuel Filter (2.5L 1989 And Up, 5.7L 1991 And Up - FIGURE E:

1. Turn off ignition.
2. Relieve the fuel pressure. Refer to the vehicle's service manual for specific pressure relief procedures.
3. Locate the fuel filter on the vehicle.
4. Remove the fuel filter by compressing the tabs while pulling outward on each fuel line. Use a container to catch any fuel that may spill out. Wipe off any excess fuel that may spill on the vehicle.
5. Install the fuel pressure Adapter (2) in place of the fuel filter by pushing each of the Adapter's male tubes into the fuel lines. Make sure the nylon clips on the tubes are seated inside the fuel line connectors.
6. Connect the Gauge (1) to the Pressure Testing and Bleed-off Assembly (25).
7. Attach the female quick coupler on the Pressure Testing and Bleed-off Assembly to the male quick coupler on the Adapter (2).
8. Start the engine and check for leaks. Read the fuel pressure. Compare the value on the Gauge (1) to the value in the service manual.
9. Stop the engine and turn the ignition OFF.
10. With free end of bleed-off hose in a suitable container, press button on side of bleed-off assembly slowly to de-pressurize the fuel system.
11. Refer to the General Safety Rules section before removing Tester from vehicle.
12. Remove the fuel pressure Adapter following the above instructions for removing the fuel filter.
13. Re-install the fuel filter. Start the engine and check for leaks.

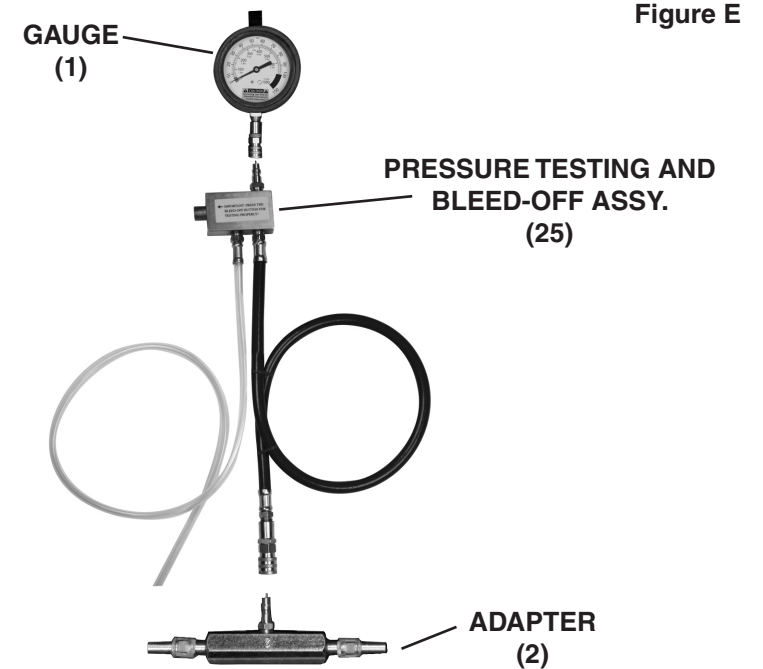

GM 2.2L Engines, 1992 And Up - FIGURE F:

1. Turn off ignition.
2. Relieve the fuel pressure. Refer to the vehicle's service manual for specific pressure relief procedures.
3. Locate the fuel filter on the vehicle.
4. Remove the fuel filter by unscrewing the steel fuel line from one end of the fuel filter. Remove the nylon fuel line on the other end by compressing the tabs while pulling outward on the fuel line. Use a container to catch any fuel that may spill out. Wipe off any excess fuel that may spill out.
5. Install the fuel pressure Adapter (3) in place of the fuel filter by threading the steel fuel line into the threaded end of the Adapter. Do not overtighten. Connect the other end of the Adapter by pushing the male tube into the nylon fuel line. Make sure the nylon clip on the tube is seated inside the fuel line connector.
6. Connect the Gauge (1) to the Pressure Testing and Bleed-off Assembly (25).
7. Attach the female quick coupler on the Pressure Testing and Bleed-off Assembly (25) to the male quick coupler on the Adapter (3).
8. Start the engine and check for leaks. Read the fuel pressure. Compare the value on the Gauge (1) to the value in the service manual.
9. Stop the engine and turn the ignition OFF.
10. With free end of bleed-off hose in a suitable container, press button on side of bleed-off assembly slowly to de-pressurize the fuel system.
11. Refer to the General Safety Rules section before removing Tester from vehicle.
12. Remove the fuel pressure Adapter (3) following the above instructions for removing the fuel filter. Re-install the fuel filter. Start the engine and check for leaks.

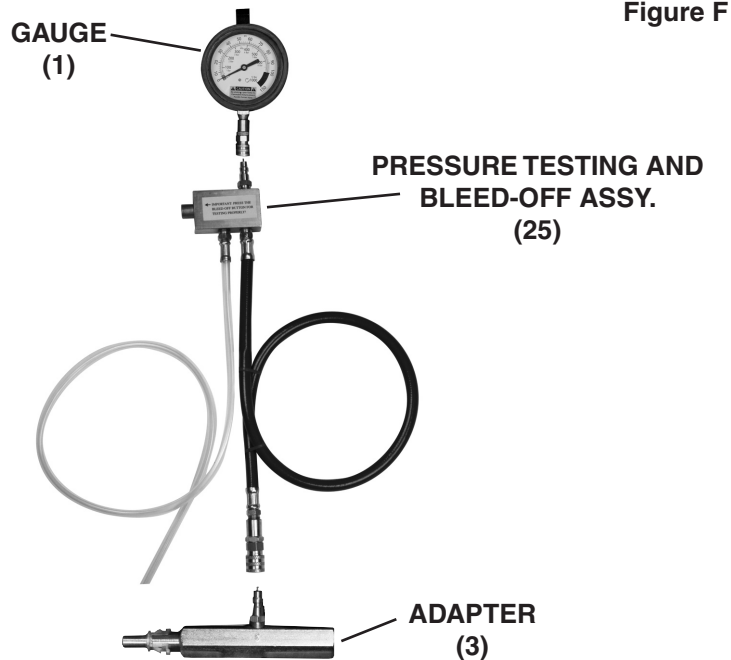

Figure F

All Vehicles With 1/4", 5/16", or 3/8" Fuel Line Hose - FIGURE K:

1. Turn off ignition.
2. Relieve the fuel pressure. Refer to the vehicle's service manual for specific pressure relief procedures.
3. Loosen the hose clamp and disconnect the fuel line hose from the inlet side of the vehicle's throttle body or discharge side of the fuel pump.
4. Assemble the Double End Barbed Adapter (7) and Hose (4) with Hose Clamps (4).
5. Connect the Double End Barbed Adapter (7) as assembled above between the disconnected fuel line and the throttle body inlet or fuel pump. Tighten all Hose Clamps (4) securely.
6. Connect the Gauge (1) to the Pressure Testing and Bleed-off Assembly (25).
7. Attach the female quick coupler on the Pressure Testing and Bleed-off Assembly (25) to the male quick coupler on the Adapter (7).
8. Start the engine and allow it to idle. Check all connections for leaks. Read the Gauge (1) and compare the result with the pressure values in the service manual.
9. Stop the engine and turn the ignition OFF.
10. With free end of bleed-off hose in a suitable container, press button on side of bleed-off assembly slowly to de-pressurize the fuel system. Refer to General Safety Rules section before removing tester from vehicle.
11. Replace the vehicle's fuel line and tighten all clamps securely. Check all connections for leaks.

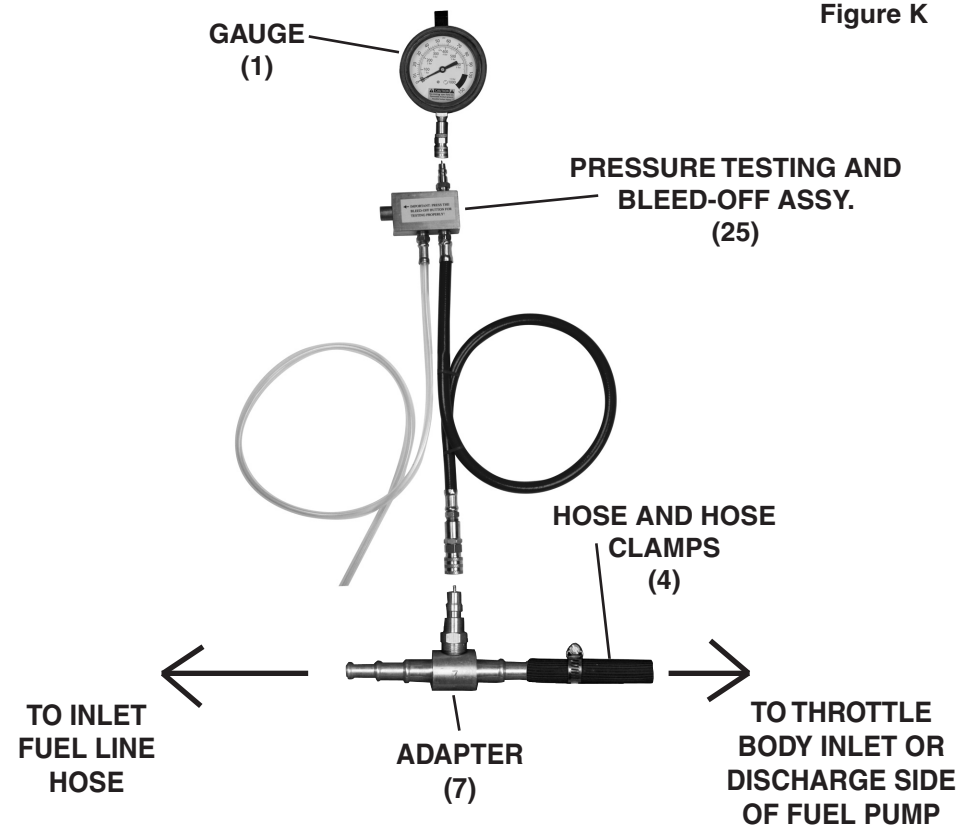

Figure K

Ford Throttle Body Injection With Small Schrader Valve - FIGURE J:

1. Turn off ignition.
2. Relieve the fuel pressure. Refer to the vehicle's service manual for specific pressure relief procedures.
3. Remove the air cleaner assembly. The test valve is located at the top of the throttle body unit.
4. Connect the Gauge (1) to the Pressure Testing and Bleed-off Assembly (25).
5. Attach the female end of the Ford Adapter (26) to the test valve.
6. Attach the female quick coupler on the Pressure Testing and Bleed-off Assembly (25) to the male quick coupler on the Adapter (26).
7. Start the engine and allow it to idle. Check all connections for leaks.
8. Read the Gauge (1) and compare the result with the pressure values in the service manual.
9. Stop the engine and turn the ignition OFF.
10. With free end of bleed-off hose in a suitable container, press button on side of bleed-off assembly slowly to de-pressurize the fuel system.
11. Refer to General Safety Rules section before removing tester from vehicle.
12. Start the vehicle and check for leaks.

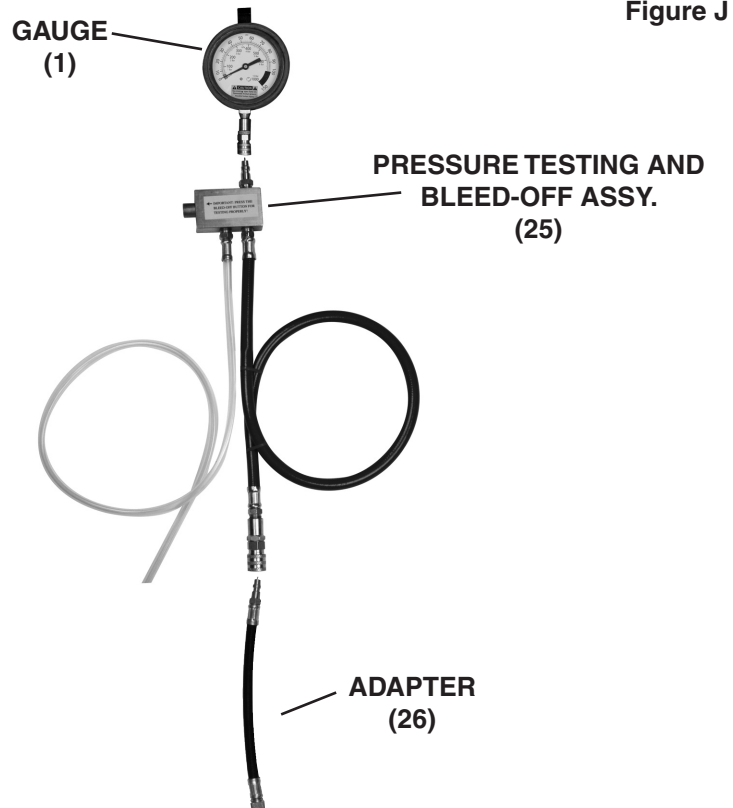

Figure J

Ford Central Fuel Injection (CFI) 1.9L and 2.3L With 5/16" Hair Pin Coupling And GM And Chrysler 3/8" Hair Pin Coupling - FIGURE G:

1. Turn off ignition.
2. Relieve the fuel pressure. Refer to the vehicle's service manual for specific pressure relief procedures.
3. The connection with the vehicle's fuel injection system is at the throttle body. Remove the fuel line at the inlet by prying up on the hair pin from the coupling with a small screwdriver. Use care as the hair pin is made of plastic. Once disconnected, re-install the hair pin into the hair pin coupling.
4. Attach the Hair Pin Adapter (28 for Ford and 29 for GM and Chrysler) to the disconnected fuel line. Make sure both ends of mating parts are seated and locked together.
5. Connect the Gauge (1) to the Pressure Testing and Bleed-off Assembly (25). Attach the female quick coupler on the Pressure Testing and Bleed-off Assembly (25) to the male quick coupler on the Adapter (28 or 29).
6. Start the engine and allow it to idle. Check all connections for leaks.
7. Read the Gauge (1) and compare the result with the pressure values in the service manual.
8. Stop the engine and turn the ignition OFF.
9. With free end of bleed-off hose in a suitable container, press button on side of bleed-off assembly slowly to de-pressurize the fuel system. Refer to General Safety Rules section before removing tester from vehicle.
10. Remove the fuel pressure Adapter following the above instructions. Re-install the vehicle's fuel line. Start the engine and check for leaks.

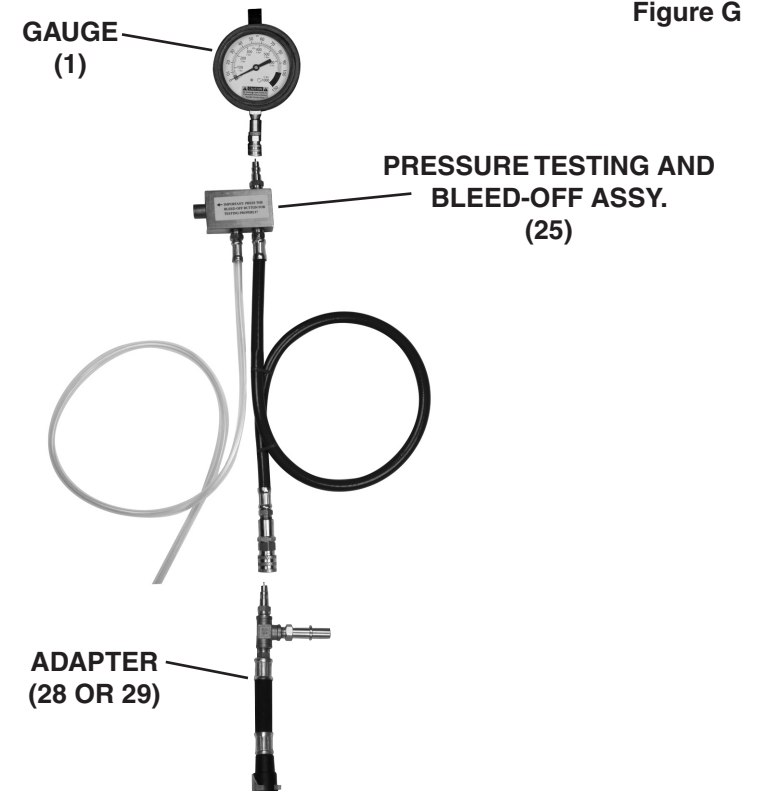
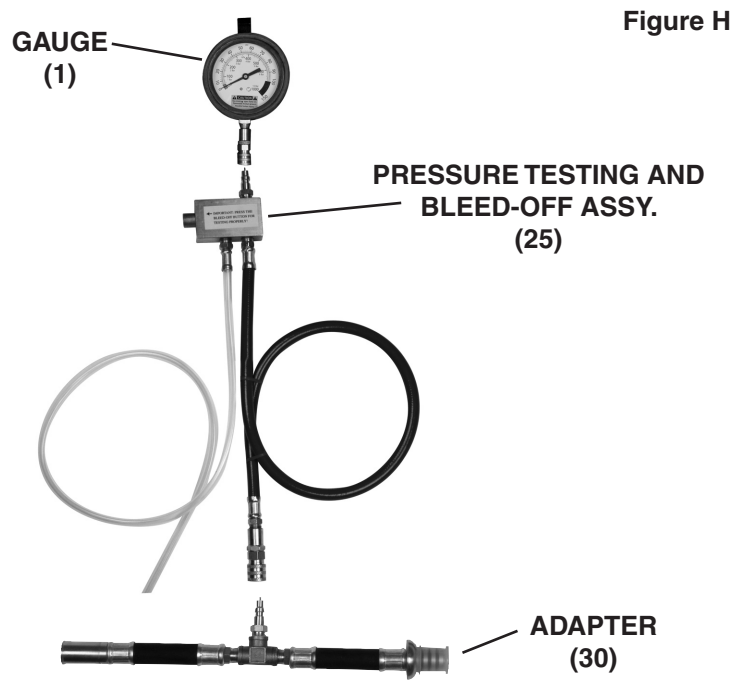

Figure G

Ford Central Fuel Injection (CFI) With Spring Lock Fittings - 2.5L - FIGURE H:

1. Turn off ignition.
2. Relieve the fuel pressure. Refer to the vehicle's service manual for specific pressure relief procedures.
3. The connection with the vehicle's fuel injection system is on the fuel rail.
4. A disconnect tool (not included) is required to separate the spring lock fitting on the vehicle's fuel line.
5. After the spring lock fitting has been disconnected, assemble the Ford Spring Lock Adapter (30) into the line, making sure both ends of the mating couplings are locked together.
6. Connect the Gauge (1) to the Pressure Testing and Bleed-off Assembly (25). Attach the female quick coupler on the Pressure Testing and Bleed-off Assembly (25) to the male quick coupler on the Adapter (30).
7. Start the engine and allow it to idle. Check all connections for leaks.
8. Read the Gauge (1) and compare the result with the pressure values in the service manual.
9. Stop the engine and turn the ignition OFF.
10. With free end of bleed-off hose in a suitable container, press button on side of bleed-off assembly slowly to de-pressurize the fuel system. Refer to General Safety Rules section before removing tester from vehicle.
11. Using a disconnect tool, remove the test Adapter (30) and install the vehicle's fuel line. Start the vehicle and check for leaks.



Honda, Acura, & Sterling Multi-Port (PGM-FI) - FIGURE I:

1. Turn off ignition.
2. Relieve the fuel pressure. Refer to the vehicle's service manual for specific pressure relief procedures.
3. The test port is at the vehicle's fuel filter, under the hood, just forward of the firewall.
4. The Fuel outlet is secured to the fuel filter by a "double D" bolt. Within this bolt is a smaller hex bolt that provides access to the test connection.
5. Place a shop cloth around the fuel outlet and slowly remove the smaller hex bolt.
6. Screw the small male end of the Honda Adapter (9) into the hole where the removed hex bolt was. Hand tighten.
7. Connect the Gauge (1) to the Pressure Testing and Bleed-off Assembly (25). Attach the female quick coupler on the Pressure Testing and Bleed-off Assembly (25) to the male quick coupler on the Adapter (9).
8. Start the engine and allow it to idle. Check all connections for leaks.
9. Read the Gauge (1) and compare the result with the pressure values in the service manual.
10. Stop the engine and turn the ignition OFF.
11. With free end of bleed-off hose in a suitable container, press button on side of bleed-off assembly slowly to de-pressurize the fuel system. Refer to General Safety Rules section before removing tester from vehicle.
12. Re-install the hex bolt on the fuel filter. Check for leaks.

