

THE INFORMATION CONTAINED IN THIS DRAWING IS THE SOLE PROPERTY OF PLASTICASE ANY REPRODUCTION IN PART OR WHOLE WITHOUT THE WRITTEN PERMISSION OF PLASTICASE IS PROHIBITED.

REVISIONS			
REV.	DESCRIPTION	DATE	APPROVED

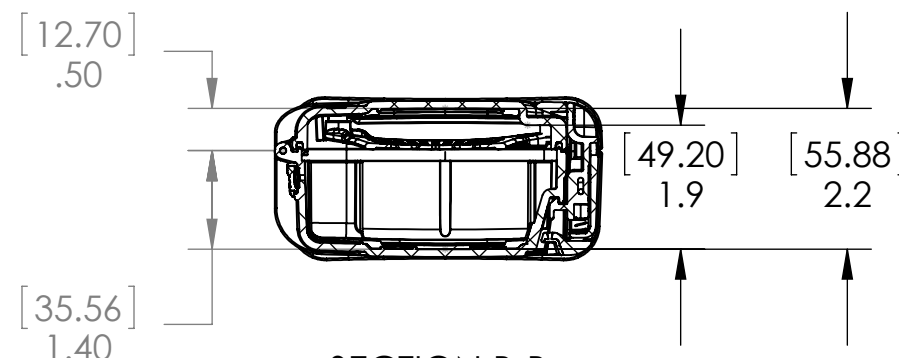
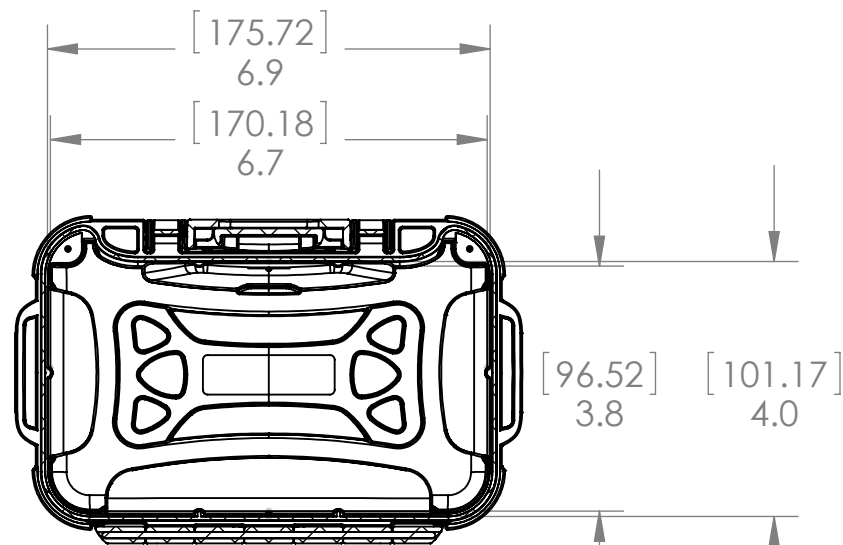
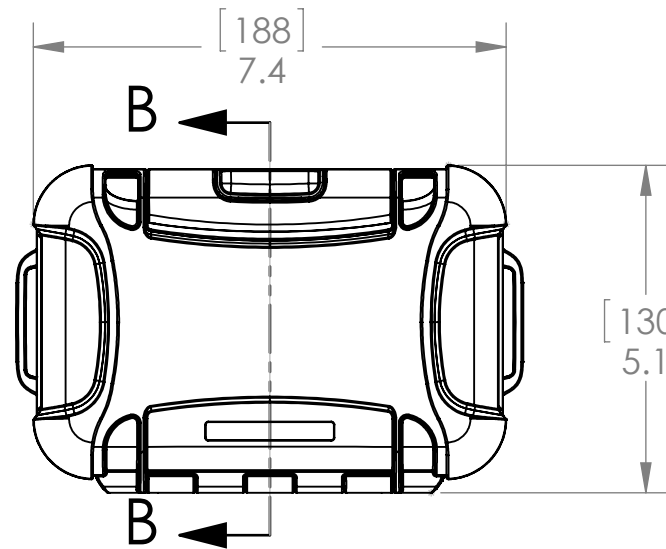
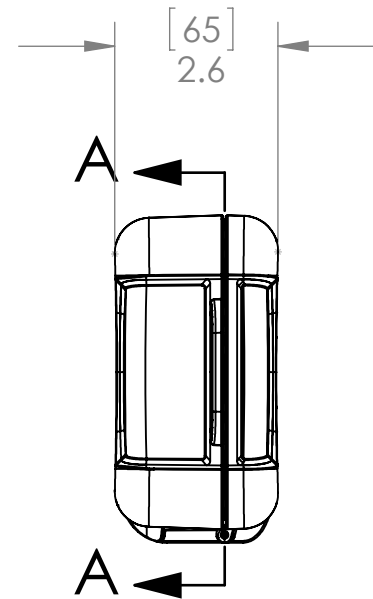
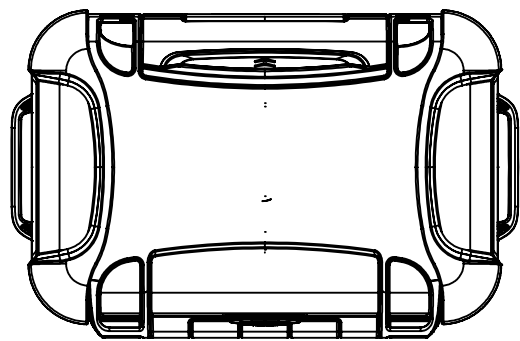
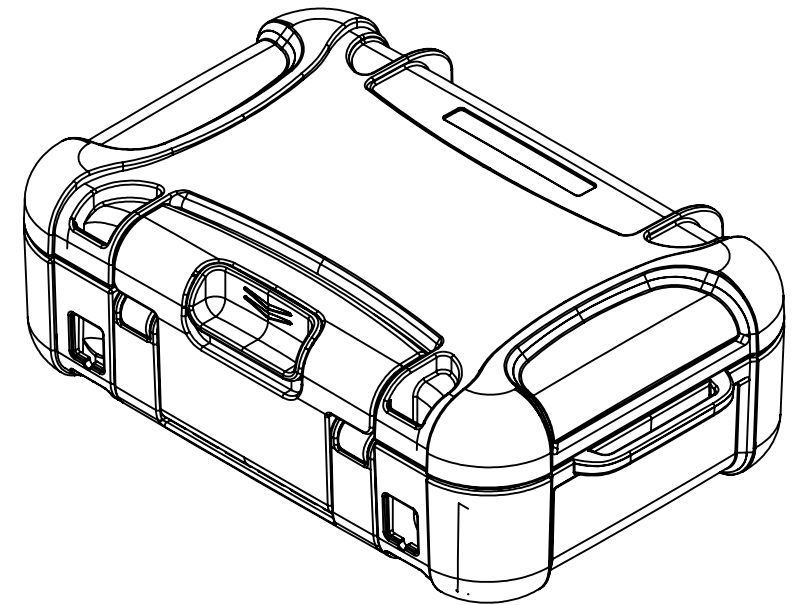
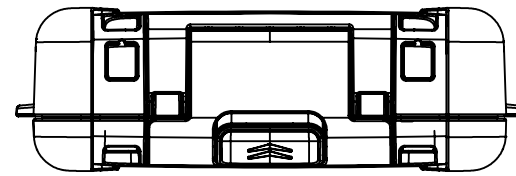

SECTION A-A  
SCALE 1 : 3

SECTION B-B  
SCALE 1 : 3

### NANUK nano 330 Specifications

Interior Length	6.7" / 170mm
Interior Width	3.8" / 96mm
Interior Height	1.9" / 49mm
Interior Lid Depth	0.66" / 17mm
Interior Base Depth	1.54" / 39mm
Exterior Length	7.4" / 188mm
Exterior Width	5.1" / 130mm
Exterior Height	2.6" / 65mm
Master Pack Qty.	10
Master Pack Wt.	11.14lbs / 5.05kg
Max Buoyancy	-
Case Weight Empty	0.8lbs / 0.4kg

PARTS LIST			
UNLESS OTHERWISE SPECIFIED DIMENSIONS ARE IN INCHES	CAD GENERATED DRAWING, DO NOT MANUALLY UPDATE		PLASTICASE
	APPROVALS	DATE	
	DRAWN B.C.	30/01/2015	NANUKNANO 330
	CHECKED		
MATERIAL	RESP ENG		
FINISH --	MFG ENG		
DO NOT SCALE DRAWING	QUAL ENG		REV.
			SCALE 1:1
			CAD FILE: AssemblageV1.9.0.large
			SHEET 1 OF 1