

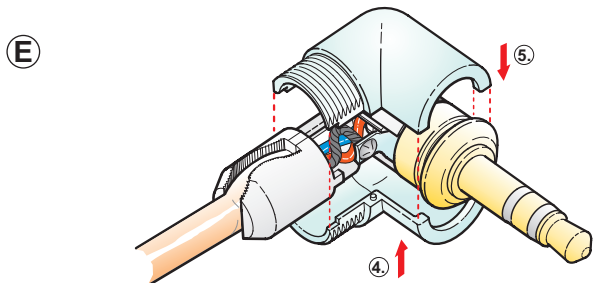

ASSEMBLY INSTRUCTION

NEUTRIK tinyPLUG | 3.5 mm right-angle stereo plug

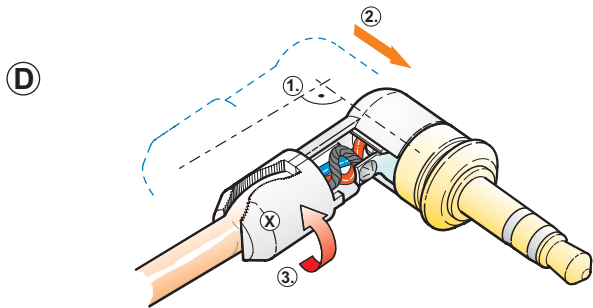
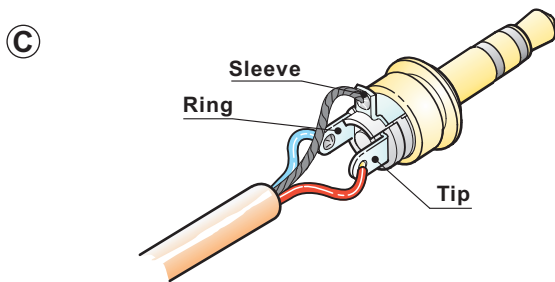
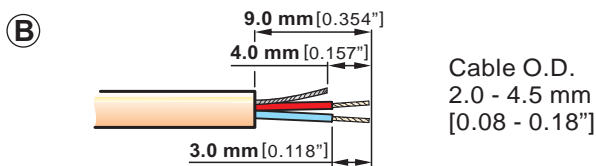
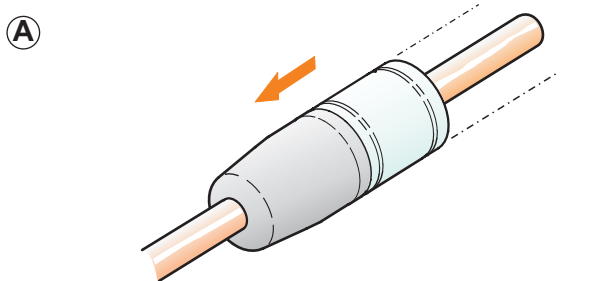

A Slide the boot onto the cable.

B Prepare cable as shown.

C Solder the wire ends .

D Assembly of strain relief:

- 1 Bend cable by 90° towards the sleeve contact.
- 2 Position the chuck on the connector body.
- 3 Close the strain relief (break away part **X** if cable O.D. > 3.2 mm)

E Place the shell halves onto the connector body.

F Slide the bushing up to the thread and tighten it.

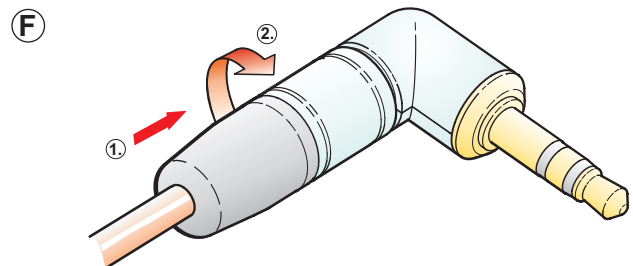

NEUTRIK AG LI T: +423 / 237 24 24 F: +423 / 232 53 93
NEUTRIK USA Inc. USA T: +1 704 / 972 3050 F: +1 704 / 438 9202
NEUTRIK (UK) Ltd. UK T: +44 1983 / 811 441 F: +44 1983 / 811 439
NEUTRIK Vertriebs GmbH DE/NL/AT/DK T: +49 8131 / 280 890 F: +49 8131 / 280 830

NEUTRIK France FR T: +33 1 / 4131 6750 F: +33 1 / 4131 0511
NEUTRIK Tokyo Ltd. JP T: +81 3 / 3663 4733 F: +81 3 / 3663 4796
NEUTRIK Hong Kong Ltd. HK T: +852 / 2687 6055 F: +852 / 2687 6052

Draft. Nr.: BDA 128 / 3102M1241 | Update: 30.07.2011 | Data subject to change without prior notice. ©2012 NEUTRIK®. ALL RIGHTS RESERVED. NEUTRIK® are registered trademark.