

# SPREES

PEAVEY ELECTRONICS

Peavey Low Rider® 18  
00560600

Peavey Low Rider® 15  
00560310

The Low Rider driver series represents a milestone in high-powered sub-woofer design. An incredible 1,600 Watt program rating and extra-long cone excursion provide maximum amounts of amazingly clean, deep bass.

The Low Rider is a superior choice for the bottom end of any high-powered sound system, from DJ rigs to the largest professional touring shows.

## DESIGN

The Low Rider utilizes a variation on the existing Kevlar®-impregnated cones used on all Black Widow® speakers. The cone is stronger and tougher and uses an innovative asymmetrical -M surround for superior excursion and motion control.

High quality spring terminals accepting large gauge wire are attached to large diameter high-current tinsel leads with silver solder to withstand high currents, high temperatures and long excursion.

The massive new voice coil uses polyimide-insulated copper ribbon wire, edge-wound and bonded onto an incredibly durable and heat-resistant polyimide composite former. The coil's winding length of 1.150" is an amazing 80% longer than Peavey's standard Black Widow coil. The long coil has a large surface area to dissipate



heat, and its increased length drives the cone to a far higher excursion. The coil is over coated with a tough thermoset epoxy for added durability, abrasion resistance and heat dissipation.

The coil wires are solderless diffusion welded to high-conductivity OFHC copper ribbon leads, which are embedded inside the former assembly and

soldered to the tinsel leads with high temperature silver solder. The solder joint is then coated with a special, thermally conductive silicone adhesive for encapsulation and heat dissipation.



The voice coil assembly is bonded to the Kevlar cone and new, incredibly tough plastiseal-coated Nomex® progressive-roll spider using a thermoset epoxy originally developed for attaching nose cones onto ICBM missiles — truly an aerospace grade adhesive. The spider and surround are bonded to the frame with a strong, toughened cyanoacrylate adhesive, which is also used to bond the dust cap to the cone.

The magnet structure is all new and was designed using extensive Finite Element computer modeling. The back plate/pole piece is cold forged from a single massive billet of ultra low carbon steel, included Peavey's patented Focused Field Geometry and is undercut to allow greater coil travel. The pole is extended beyond the front plate to improve coil cooling and make it more magnetically linear and the front plate is 10mm thick to match the long voice coil and provide a better path for heat and magnetic energy. The result is 50% more total magnetic gap energy than can be found in the standard Black Widow Super Structure magnet assembly.

A patent pending vent plate greatly improves voice coil cooling. This heat conductive, ported and finned aluminum ring delivers cool air pumped by the spider directly to the voice coil to keep operating temperatures under control. The improved cooling increases power handling and reliability and reduce power compression.

The cast aluminum frame is tough and rigid and has the strength needed to hold the cone and huge magnet assembly in perfect alignment. The deep dish design and large spider clearance make high excursion and high output possible.

These dynamic new drivers also utilize the user friendly Black Widow replaceable basket assemblies with Rubatex® gaskets.

The result of these specially designed components are truly amazing loudspeakers. The Low Rider's astonishing low frequency output is due to its high power handling capability and its 1.4" of available cone movement. These speakers can also be used with small enclosures, adding a new dimension to compact, high output sound reinforcement systems.

### **APPLICATIONS**

The Low Rider® is specifically designed for sub woofer use, with extremely high output capabilities and massive power handling. While most sub woofer applications are below 150 Hz, it is usable to frequencies as high as 500 Hz.

The compact enclosure designs are ideal for instrument amplification and high portability applications such as DJ and small touring bands. They provide solid bass performance in extraordinarily small enclosures. Band pass enclosures also fit into this range as standalone sub woofers.

The medium sized enclosures are still smaller than usual and have more bass extension and much higher output capabilities than conventional designs. They are excellent choices for high performance sound reinforcement. These designs are the best combination of size and bass performance.

For permanent installations and applications requiring extremely deep bass performance, the large vented enclosures are ideal. The low frequency extension and high sound pressure levels these systems can produce is astounding. As is typical in large, vented systems with low vent tuning, power handling is reduced by at least 15% due to the increased cone excursion.

Due to the Low Rider's high output capabilities, excessive level may cause structural damage to buildings or induce permanent

hearing loss, nausea, vertigo or intestinal disturbances in listeners. Please be cautious when setting maximum sound pressure levels.

### **ENCLOSURES**

To assist with the growing interest in home built enclosure designs, Peavey includes complete parameter data on these drivers and also provides the user with several recommended enclosure designs. This information and much more can be found at [www.peavey.com](http://www.peavey.com).

The 18" Low Rider driver performs best with vented enclosure between 5 and 9 cubic feet (142 to 255 liters) and vent tunings from 30 to 45 Hz. The Low Rider 18 is optimized for vented systems but will also work with appropriate single reflex bandpass enclosures. Sealed, infinite baffle, horn, transmission line and dual reflex bandpass enclosures are not recommended.

The Low Rider 15" driver works best in vented enclosures between 2 and 5 cubic feet (56.6 to 141.6 liters) and vent tunings from 34 to 45 Hz. It can also be used in certain single reflex bandpass designs. As with the Low Rider 18, sealed, infinite baffle, horn, transmission line and dual reflex bandpass enclosures are not recommended.

Active filtering must be included with amplifiers greater than 750 watts. This filter should be a high pass 24dB Butterworth at a minimum of 25 Hz for the 18" and 32 Hz for the 15". Filtering is also recommended below 750 watts in order to conserve amplifier power and reduce excessive cone motion. Failure to use filtering with high power operation may cause driver damage that can void your warranty.

Strength of the completed enclosure has a great effect on the bass performance of the finished system. Internal bracing is required

to improve the structural strength of the cabinet. Low Riders can generate enormous forces inside the enclosure, and panels that aren't stiff enough will vibrate or if the cabinet panels are not stiff enough add more bracing.

Vents shown in the examples require standard Schedule 40 PVC pipe for vent construction. The pipe should be dadoed tightly into the back of the baffle and glued firmly in place with high quality epoxy or high strength industrial grade hot glue. Roughen up the outside of the pipe to improve the glue bond. Radius the insides of the vent end to improve air flow and reduce vent noise.

Vents for these enclosures are much longer than typical for a sound reinforcement sub woofer. This reflects the special characteristics of the Low Riders design that make it possible to combine a large, high excursion woofer with an unusually small enclosure. For best performance, the inside ends of the vents should be a distance of at least one vent diameter from any interior wall of the enclosure. The vent should be straight, without elbow fittings or other methods to bend it for greater length. Vent diameter should not be decreased, as high air velocity will result in noise and reduced power handling.

Be sure to allow for the displacement of the vent, bracing and woofer in your enclosure design before building it. Mistakes in net volume will mis-tune the enclosure and can drastically reduce performance. This requires a considerably amount of planning before construction, but is well worth the extra effort.

Line the inside of the enclosure with polyester fiber batting such as quilt stuffing. For bandpass loosely fill the sealed side, leave the vented side empty, and place the low Rider's magnet in the vented side for cooling. The

batting material should conform to California bedding fire codes. Attach the batting with spray adhesive or staples and keep material away from the end of the vent tube where it can be pulled in by air flow.

Handles, protective corners, cabinet covering, grille materials and crossovers are available through Peavey Accessories. Take particular care when positioning handles, as sub woofers tend to be large and heavy.

Do not use ¼" phone plugs or jacks in the construction of your enclosures. Power capacity of Low Rider sub woofers is well above safe limits for phone plugs and jacks. Neutrik® Speakon® connector's are highly recommended, and internal cabinet wiring should be at least 16 gauge stranded copper wire.

These instructions are a general guideline for design. Proper construction techniques, good planning and common sense will result in a reliable, high quality, high performance system.

Peavey in no way accepts liability for any damage, accidents or injury that may result from design, construction or operation of enclosures using this information. Due to Peavey's continuing efforts to improve products, features and specifications are subject to change without notice.

## PARAMETERS

Thiele-Small parameters for Low Rider subwoofers follow. This data is for use in designing enclosures. Numerous software packages are available that use this data to simulate the response of the driver and enclosure together for optimum performance in any application.

## PARAMETER DEFINITIONS

**Znom:** The nominal impedance of the driver in Ohms.

**Revc:** DC resistance of the driver in ohms, also known as Re.

**Sd:** The functional radiating surface area of the cone assembly in meters 2.

**BL:** Efficiency of the voice coil and magnet system in Tesla meters.

**Fo:** Free air resonance. Also known as Fs.

**Vas:** Volume of air having the same compliance (springiness) as the driver's suspension.

**Cms:** Restorative force of the driver's suspension in micrometers/Newton.

**Mms:** The total mass of the moving parts of the loudspeaker, including the air load, in grams.

**Qms:** Resonance characteristics of the mechanical factors of the loudspeaker.

**Qes:** Resonance characteristics of electrical factors of the loudspeaker.

**Qts:** Resonance characteristics of the electrical and mechanical factors combined together.

**Xmax:** Distance the cone can move in one direction before the coil begins to leave the magnetic gap.

**Le:** Inductance of the voice coil in millihenries.

**SPL:** Typical sound pressure level at 1 watt, 1 meter.

**no:** Electrical to acoustical conversion efficiency in percent.

**Vd:** Air displacement of the driver from negative Xmax to positive Xmax.

**Pmax:** Maximum continuous program power in watts.

**Disp:** Volume displaced by the driver inside the cabinet when mounted on its rear flange.

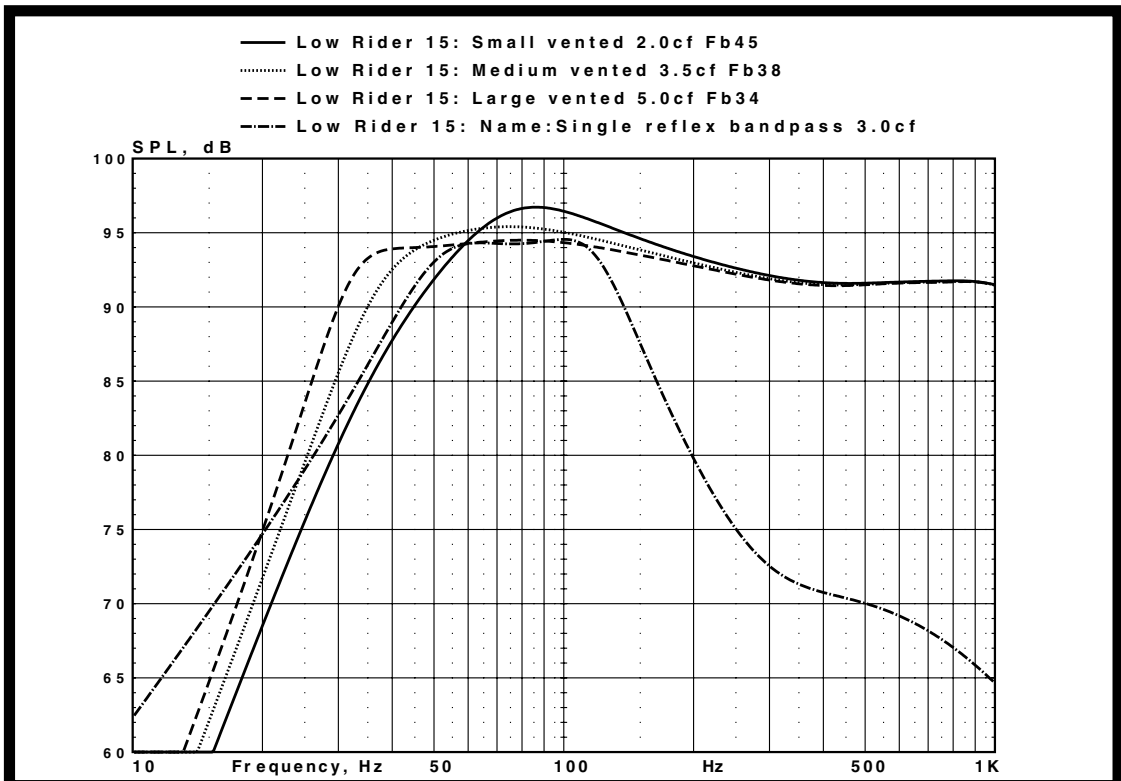
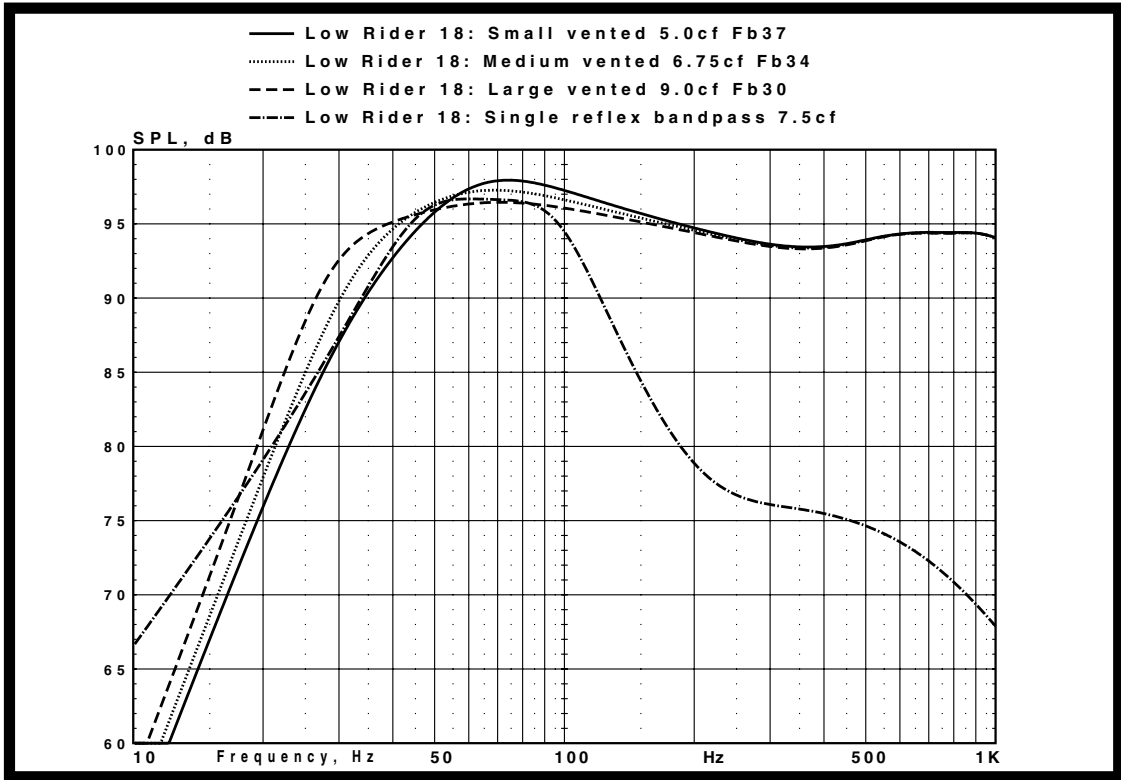



<b>SPECIFICATIONS</b>	<b>Low Rider® 18"</b>	<b>Low Rider® 15"</b>
Part #	00560600	00560310
Size: inches	18"	15"
Frame OD inches	18-1/8"	15-1/4"
Bolt circle inches	17-3/8"	14-9/16"
Cutout diameter inches	16-3/8"	14"
Depth	6-3/8"	5-1/4"
Impedance	8 Ohms	8 Ohms
Power Capacity:	3200 Watts peak	3200 Watts peak
	1600 Watts program	1600 Watts program
	800 Watts continuous	800 Watts continuous
Sensitivity:	97.3 dB / 1 W 1 m	93.6 dB / 1 W 1 m
Usable frequency range:	25 Hz -1 KHz	30 Hz -1 KHz
Cone:	Kevlar® impregnated cellulose	Kevlar® impregnated cellulose
Voice Coil diameter:	4.0"	4.0"
Voice Coil material:	Polyimide coated copper ribbon wire Polyimide – impregnated fiberglass former Nomex® stiffener Solderless diffusion welded OFHC copper leads	Polyimide coated copper ribbon wire Polyimide – impregnated fiberglass former Nomex® stiffener Solderless diffusion welded OFHC copper leads
Net weight:	22 lbs. / 10 kg	21 lbs. / 9.5 kg
Znom (ohms)	8	8
Revc (ohms)	6.21	6.21
Sd (Square Meters)	0.134	0.084
BL (T/M)	22.17	22.73
Fo (Hz)	28.9	33.9
Vas (liters)	288.0	155.1
Cms (uM/N)	113.3	154.8
Mms (gm)	198.20	142.30
Qms	9.07	10.67
Qes	0.451	0.364
Qts	0.429	0.352
Xmax (mm)	9.6	9.6
Le (mH)	0.87	0.82
SPL (1 W 1m)	96.0	93.6
no (%)	2.65	1.33
Vd (cubic inches/milliliters)	145 / 2375	98.4 / 1611
Pmax (Watts pgm.)	1600	1600
Disp (inches/milliliters)	235 / 3852	204 / 3344

## SUGGESTED ENCLOSURES

For those who want to build their own enclosures but don't want to go through the design process using driver parameters, Peavey provides the following optimized designs:

### For Low Rider 18:

ENCLOSURE	NET VOLUME Cubic feet/liters	VENT DIAMETER (qty) inches/mm	VENT LENGTH inches/mm	Vb BOX TUNING frequency in Hz	F3, -3 Db point in Hz
Small Vented Box	5.0 / 14	(2) 6" / 152	15.25 / 387	37	40
Medium Vented Box	6.75 / 191	(2) 6" / 152	12.75 / 324	34	35
Large Vented Box	9 / 255	(2) 6" / 152	12 / 305	30	31
Single-Reflex Bandpass	Sealed: 4.0 / 113 Vented: 3.5 / 85	(2) 6" / 152	5.0 / 127	65	40 – 104

#### 1. Small Vented Box

This enclosure is as small as many 15" cabinets but has better bass performance and handles tons of power. This design is an excellent choice for large touring systems because it can handle a large number of enclosures at the same load out volume.

#### 2. Medium Vented Box

This enclosure offers an exceptional combination of deep bass extension, high power handling and reasonable size. It is capable of extremely high output below 40Hz.

#### 3. Large Vented Box

This box produces superb performance in the bottom octave for high level playback, movie theaters, special effects and permanent installation. It reduces power handling by at least 15% but offers usable output to 25Hz.

#### 4. Single Reflex Bandpass

This special design uses the enclosure as an acoustic filter for shaped response. It's not as efficient as a vented system, but it doesn't require a crossover for sub woofer use.

### For Low Rider 15:

ENCLOSURE	NET VOLUME Cubic feet/liters	VENT DIAMETER (qty) inches/mm	VENT LENGTH inches/mm	Vb BOX TUNING frequency in Hz	F3, -3 Db point in Hz
Small Vented Box	2.0 / 56.6	(2) 4" / 102	12 / 305	45	48
Medium Vented Box	3.0 / 85.0	(1) 6" / 152	12.75 / 324	38	40
Large Vented Box	4.5 / 127.4	(3) 4" / 102	12 -5/8 / 321	34	33
Single-Reflex Bandpass	Sealed: 1.8 / 51.0 Vented: 1.3 / 36.8 (3)	6" / 102	9-3/4 / 248	78	45 – 131

#### 1. Small Vented Box

This incredibly tiny enclosure has good bass performance and serious power capacity. An excellent choice for very compact, high powered systems and bass guitar/keyboard enclosures.

#### 2. Medium Vented Box

This enclosure is an exceptional compromise of deep bass extension, high power handling, and compact size. It is capable of extremely high output to below 40Hz for excellent performance.

#### 3. Large Vented Box

The large vented box extends superb performance into the bottom octave for high level playback, movie theater, special effects and permanent installation. The enclosure reduces power handling by at least 15% but offers usable output to below 35Hz.

#### 4. Single Reflex Bandpass

Special enclosure design that uses the enclosure as an acoustic filter for shaped response. Not as efficient as a vented system, but it doesn't require a crossover for sub woofer use.

# Peavey Lo Rider® speakers

feature convenient field-replaceable baskets. Replaceable baskets eliminate the need for re-coning speakers and the frustration and delays associated with the re-coning process. It only takes a few minutes to replace a basket and you are back in business. It just can't get any easier than the four steps outlined here.

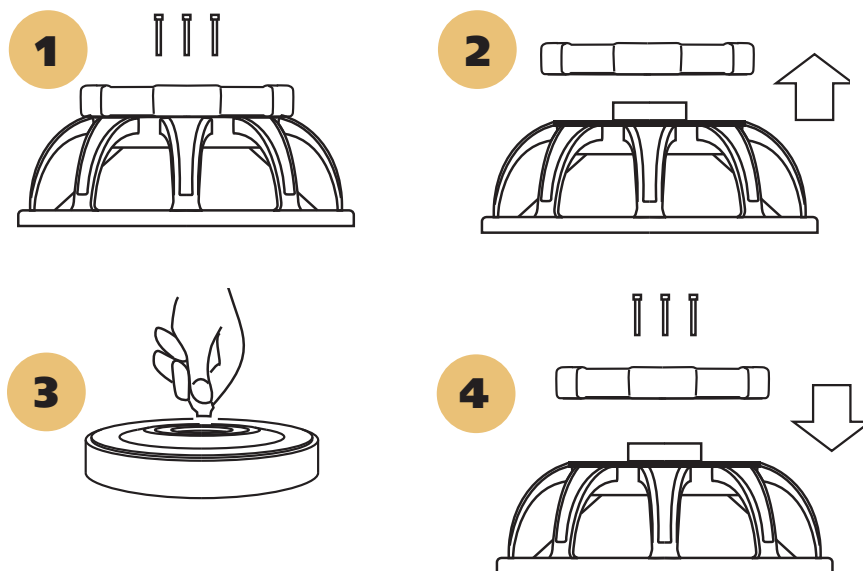

## **Baskets are replaced in four easy steps:**

- 1** Remove three screws on back of magnet structure.
- 2** Lift the magnet structure off the basket frame.
- 3** Clean the voice coil "gap".
- 4** Align screw holes, lower structure into place on new basket frame, insert screws and tighten.

## **ONE YEAR LIMITED WARRANTY**

NOTE: For details, refer to the warranty statement. Copies of this statement may be obtained online at [www.peavey.com](http://www.peavey.com).



*Features and specifications subject to change without notice.*

**Peavey Electronics Corporation • 5022 Hartley Peavey Drive • Meridian • MS • 39305  
(601) 483-5365 • FAX (601) 486-1278 • [www.peavey.com](http://www.peavey.com)  
©2011 Printed in the U.S.A. 9/11 80306026**