

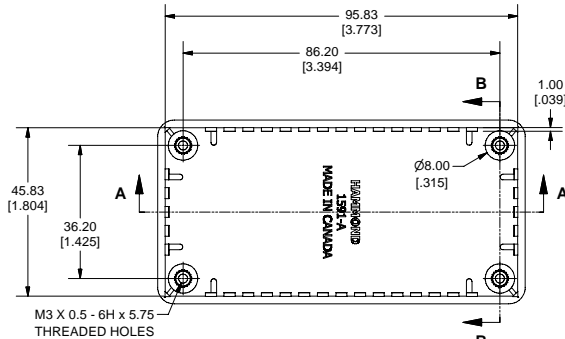

SIDE VIEW OF BOX

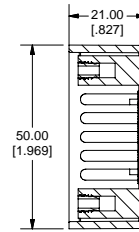

TOP VIEW OF BOX



SECTION B-B

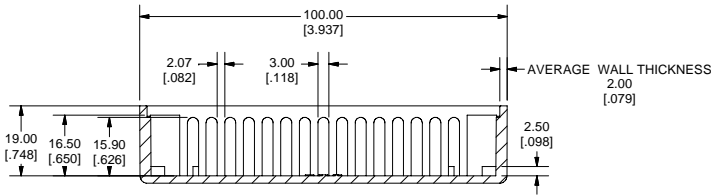
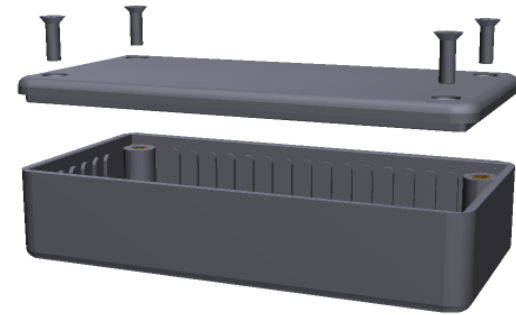

SECTION A-A

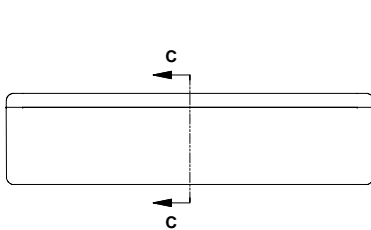

SIDE VIEW OF ASSEMBLY

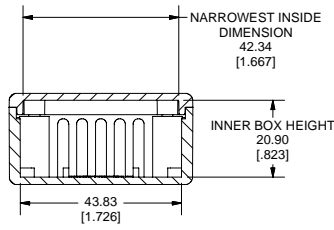

SECTION C-C

Note:
Enclosures can be Factory Modified (Milling, Drilling, Printing etc.)
Contact Factory mjm@hammondmfg.com for quotes
Solid models of this enclosure available in STEP or IGES Format.

PART NUMBERS

1591A Enclosures		
Material	Colour	Part Number
FR ABS UL94 - V0	Beige	1591ABG
	Black	1591ABK
	Blue	1591ABU
	Grey	1591AGY
GP ABS	Black	1591ASBK
	Grey	1591ASGY
	Ice Blue	1591ATBU
Translucent Polycarbonate	IR Red	1591ATRD
	Crystal Clear	1591ATCL

Accessories

	Description	Part Number
Universal Use	PC Board Card Adapters	See Accessories Section
	Clear Lids - clear, flame retardant polycarbonate - Lid ONLY	1591AC
	Replacement Screws, Flat Head Phillips Nickel Plated Pkg of 100	1591MS100 1591MS100BK (Black)
GP ABS	Self Tapping Pkg of 100	1591TS100 1591TS100BK (Black)

Recommended Torque on Fasteners (no lubrication)

M3 - 0.5 x 10mm Screws	30-40 cN*m
#4 x 0.5 Screws	30-40 cN*m

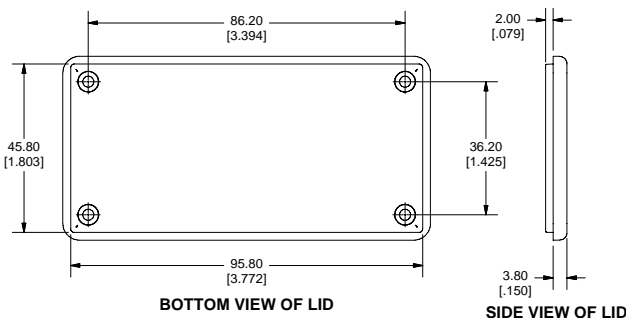

BOTTOM VIEW OF LID

SIDE VIEW OF LID

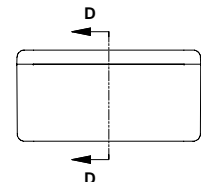

END VIEW OF ASSEMBLY

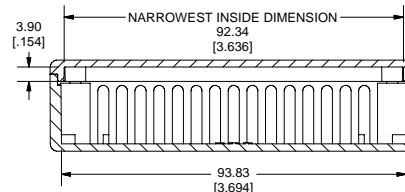

SECTION D-D

