

Note:
 Enclosures can be Factory Modified (Milling, Drilling, Printing etc.)
 Contact Factory mjm@hammondmfg.com for quotes
 Solid models of this enclosure available in STEP or IGES Format.

PART NUMBERS		
1591G Enclosures		
Material	Colour	Part Number
FR ABS UL94 - V0	Beige	1591GBG
	Black	1591GBK
	Blue	1591GBU
	Grey	1591GGY
GP ABS	Black	1591GSBK
	Grey	1591GGSY
Accessories		
	Description	Part Number
Universal Use	PC Board Card Adapters	See Accessories Section
	Clear Lids - clear, flame retardant polycarbonate - Lid ONLY	1591GC
FR ABS	Replacement Screws, Flat Head Phillips Nickel Plated Pkg of 100	1591MS100 1591MS100BK (Black)
GP ABS	Self Tapping Pkg of 100	1591TS100 1591TS100BK (Black)
Recommended Torque on Fasteners (no lubrication)		
	M3 - 0.5 x 10mm Screws	30-40 cN*m
	#4 x 0.5 Screws	30-40 cN*m

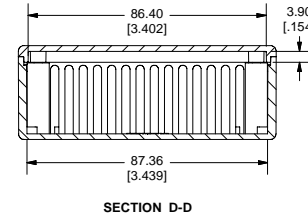
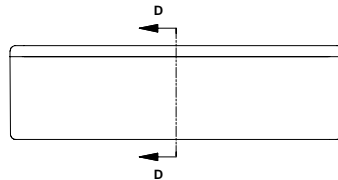
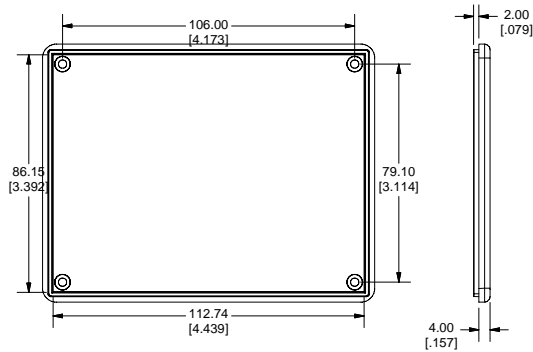

HAMMOND MANUFACTURING™
 1591G
www.hammondmfg.com