

Enclosures can be Factory Modified (Milling, Drilling, Printing etc.)
 Contact Factory mjm@hammondmfg.com for quotes
 Solid models of this enclosure available in STEP or IGES.
 (Part number and text placement/orientation on our products are subject to change,
 we do not recommend using them as a locating reference for modification purposes)

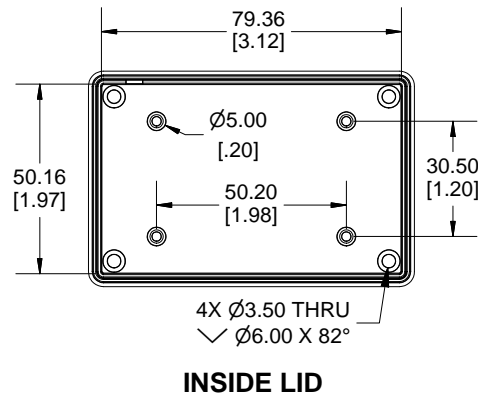
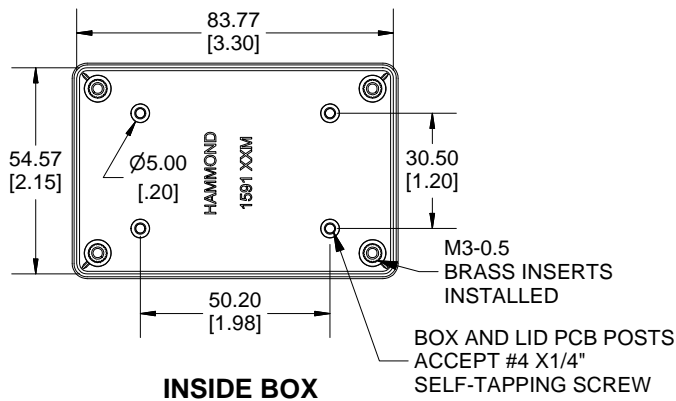

NOTE	
Tab dimensions show maximum size, tab may vary.	
Purchased assembly includes box, lid, 4 cover screws and installed brass inserts.	
Enclosure molded from FRABS UL 94-V0 Plastic.	
Other materials / colours available consult factory.	
Recommended Torque : (43-50) Ozf.in / (30-35) cN.m	

PART NUMBERS	
1591XXM Enclosure	
Black Textured Enclosure	1591XXMBK
Gray Textured Enclosure	1591XXMGY
Translucent Blue Textured Enclosure	1591XXMTBU
ACCESSORIES	
Black Cover Screws [M3-0.5 X 10mm]	1591MS100BK (Pkg 100)
Plated Cover Screws [M3-0.5 X 10mm]	1591MS100 (Pkg 100)
Black ABS Mounting Flange	1591FMBK
Grey ABS Mounting Flange	1591FMGY
P.C. Board Screws	1593ATS50 (Pkg 50)
#4 x 1/4" self-tapping (6.4mm)]	1593ATS100 (Pkg 100)

Dimensions:
mm
[inches]

**HAMMOND
MANUFACTURING®**

1591XXM

www.hammondmfg.com