

**TOP VIEW**

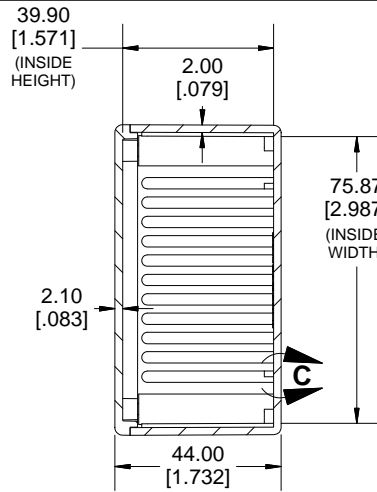

**SECTION A-A**

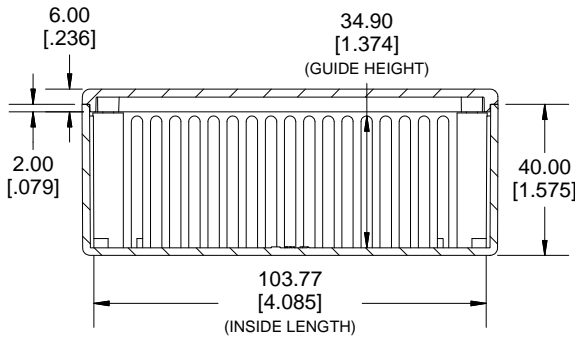
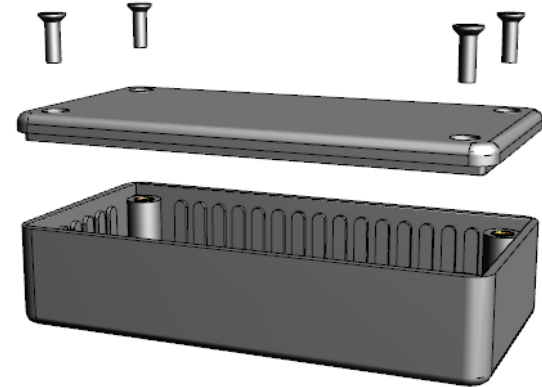

**SECTION B-B  
SIDE VIEW**

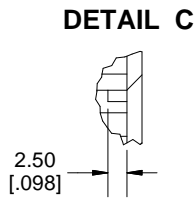

**DETAIL C**

**DETAIL D**

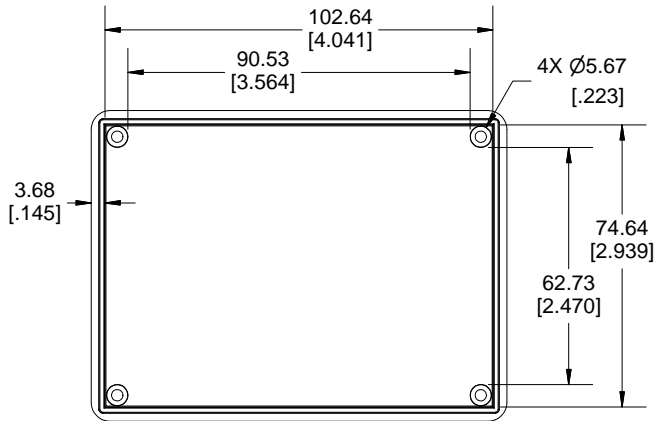
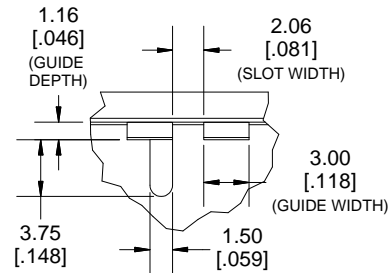

**INSIDE LID**

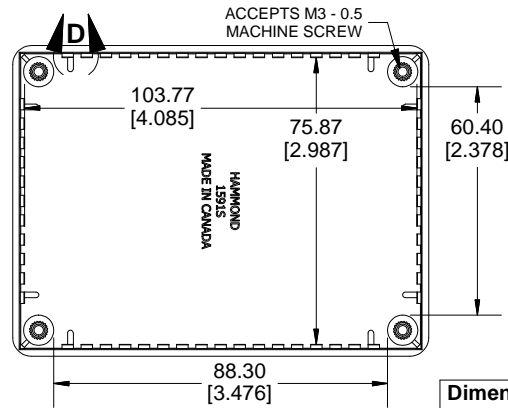

**INSIDE BOX**

**Dimensions:**  
mm  
[inches]

Enclosures can be Factory Modified ( Milling, Drilling, Printing etc.)  
Contact Factory [mjm@hammondmfg.com](mailto:mjm@hammondmfg.com) for quotes  
Solid models of this enclosure available in STEP or IGES.

**NOTE**

Purchased assembly includes box, lid, 4 cover screws, and pre-installed brass inserts.  
Enclosure made from FRABS or Polycarbonate.

**Recommended Torque: 42-57 ozf.in (30-40 cN.m)**

**PART NUMBERS**

1591S Enclosure		
Material	Colour	Part Number
FR ABS UL94 -V0	Beige	1591SBG
	Black	1591SBK
	Blue	1591SBU
	Grey	1591SGY
Translucent Polycarbonate	Ice Blue	1591STBU
	IR Red	1591STRD
	Crystal Clear	1591STCL
Accessories		
Plated Cover screw M3 - 0.5 X 10mm (100Pkg)		1591MS100 (Silver)
		1591MS100BK (Black)
PC Board Card Adapters		1591Z6 (6Pkg)
		1591Z50 (50 Pkg)
		1591Z100 (100Pkg)
Nylon Belt / Pocket clip		1599CLIP (Black)
		1599CLIPGY (Grey)
Clear Lids - Flame Retardant Polycarbonate - Lid ONLY		1591SC

**HAMMOND  
MANUFACTURING®**

**1591S**

[www.hammondmfg.com](http://www.hammondmfg.com)