



Designed for Fun, Built to Last®

BREAKAWAY 41-IN. DOME HOCKEY TABLE ASSEMBLY INSTRUCTIONS



**Please Do Not Hesitate to
Contact Our Consumer Hotline
at 800-759-0977
with Any Questions That May
Arise During Assembly or
Use of This Product!**

THANK YOU!

Thank you for purchasing this product. We work around the clock and around the globe to ensure that our products maintain the highest possible quality. However, in the rare case of issues during assembly or use of this product, please contact our Consumer Hotline at **800-759-0977** for immediate assistance before contacting your retailer. Please read the warranty information at the back of these assembly instructions for further details.

ASSEMBLY TIPS

IMPORTANT! PLEASE READ THESE ASSEMBLY INSTRUCTIONS IN ENTIRETY BEFORE ASSEMBLING YOUR PRODUCT.

1. Find a clean, level surface to begin the assembly of your game table. We recommend that two adults work together to assemble this game. You may want to carefully cut or tear the four corners of the box so that the bottom of the box can be used as your work surface.
2. Remove all of the contents from box and verify that you have all of the parts shown on the Parts List before you begin assembly. **Note: Some parts may be pre-installed or pre-assembled.**
3. Some figures or drawings may not look exactly like product.
4. **When installing parts that have more than one screw or bolt, hand tighten all screws or bolts in place before final tightening with screwdriver or wrench.**
5. Electric screwdrivers may be helpful during assembly; however, please set a **low torque** and use extreme caution because screws may be stripped or overtightened, resulting in damaged parts, if the electric screwdriver's torque is set too high.



CARE AND USE

1. This product is intended for **INDOOR** use only.
2. Do **NOT** drag the table when moving it, as this will damage the legs.





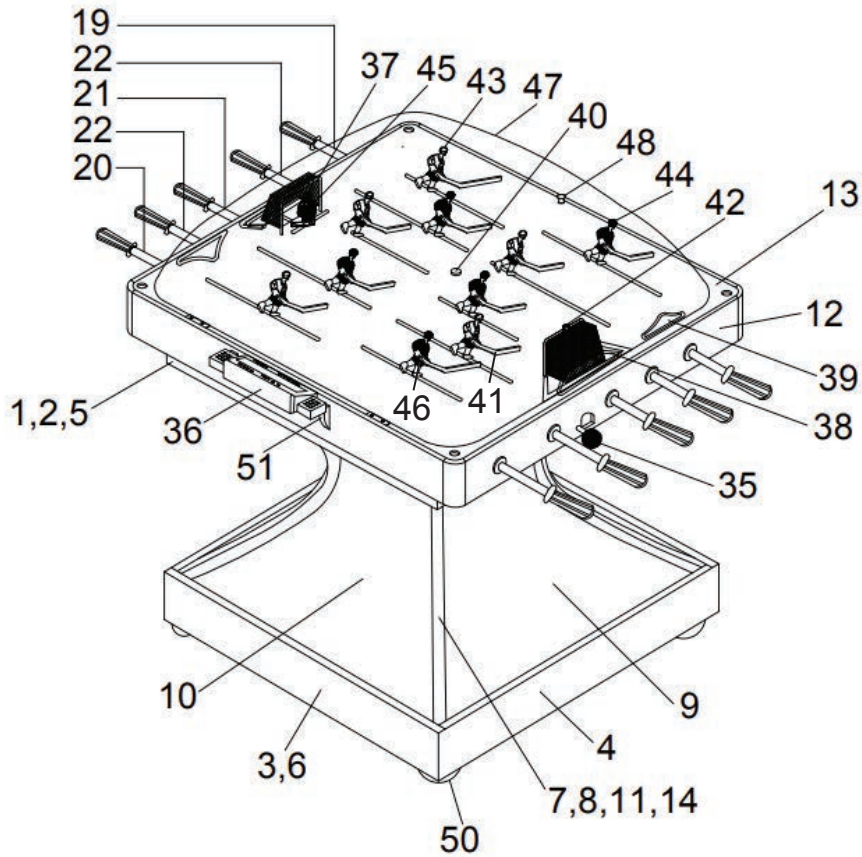





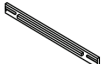
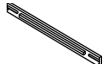

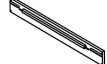



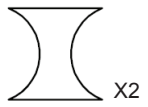
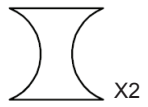

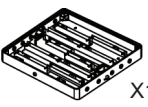
BREAKAWAY DOME HOCKEY TABLE - BG5003

Parts List



Illustrations Not to Scale













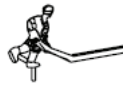

PARTS

#1 NGP7113  X2 TOP APRON A	#2 NGP7114  X2 TOP APRON B	#3 NGP7115  X2 BOTTOM APRON A	#4 NGP7116  X2 BOTTOM APRON B	#5 NGP7117  X4 TOP CONNECT BOARD	#6 NGP7118  X4 BOTTOM CONNECT BOARD	#7 NGP7119  X1 CROSSBEAM A
#8 NGP7120  X1 CROSSBEAM B	#9 NGP7122  X2 LEG PANEL A	#10 NGP7123  X2 LEG PANEL B	#11 NGP7124  X4 CURVED LEG TRIM	#12 NGP7125  X1 UPPER CABINET	#13 NGP7126  X1 PLAYFIELD	#14 NGP7121  X2 SUPPORT PLATE
#19 NGP7127  X2 LONG ROD	#20 NGP7128  X2 MIDDLE ROD A	#21 NGP7129  X2 MIDDLE ROD B	#22 NGP7130  X4 SHORT ROD	#23 NGP7131  X10 ROD SPRING	#35 NGP7132  X2 GOALIE CONTROL	#36 NGP7133  X1 ELECTRONIC SCORER



















BREAKAWAY DOME HOCKEY TABLE - BG5003

Parts List

PARTS

#37 NGP7134  X2 GOAL	#38 NGP7135  X2 PLAYFIELD GOAL BUMPER	#39 NGP7136  X2 PLAYFIELD END BUMPER	#40 NGP7102  X2 PUCK	#41 NGP7138  X4 RED SHORT STICK PLAYER	#42 NGP7139  X1 RED GOALIE	#43 NGP7140  X1 RED LONG STICK PLAYER
#44 NGP7141  X4 BLUE SHORT STICK PLAYER	#45 NGP7142  X1 BLUE GOALIE	#46 NGP7143  X1 BLUE LONG STICK PLAYER	#47 NGP7144  X1 DOME	#48 NGP7145  X1 DOME HANDLE	#50 NGP7146  X4 LEG LEVELER	#51 NGP7147  X2 SCORER L-BRACKET
#52 NGP7103  X1 ADAPTER	#55 NGP7104 Part of Table Body (A & B wires: 1 wire set per goal) SCORER SENSOR WIRE					

HARDWARE PACK - NGP7148

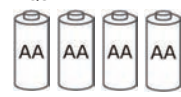
#15 X16  SCREW	#16 X32  SCREW	#17 X4  BOLT	#18 X4  WASHER	#24 X10  BOLT	#25 X8  SCREW	#26 X10  WASHER
#27 X2  NUT	#28 X8  NUT	#29 X2  SCREW	#30 X4  SCREW	#31 X4  BOLT	#32 X4  WASHER	#33 X12  SCREW
#34 X4  BOLT	#49 X1  SCREW	#53 X1  WRENCH	#54 X1  WRENCH	ADDITIONAL EQUIPMENT REQUIRED:  PHILLIPS HEAD SCREWDRIVER	ADDITIONAL EQUIPMENT REQUIRED:  4 AA BATTERIES (NOT INCLUDED)	

ASSEMBLY INSTRUCTIONS

STEP 1

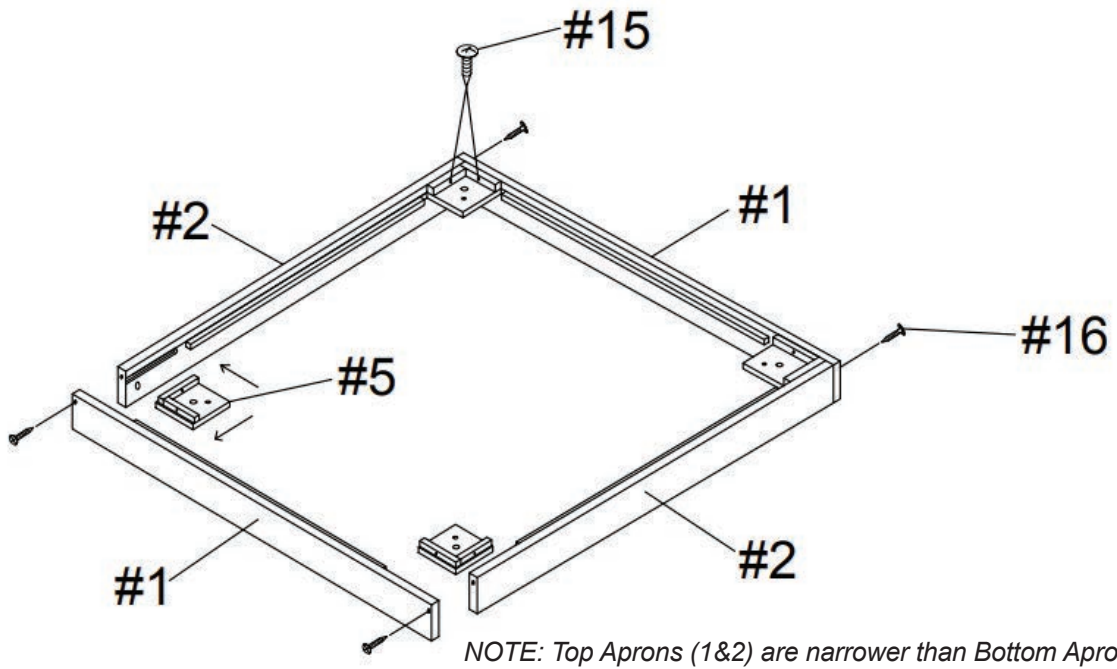

STEP 2

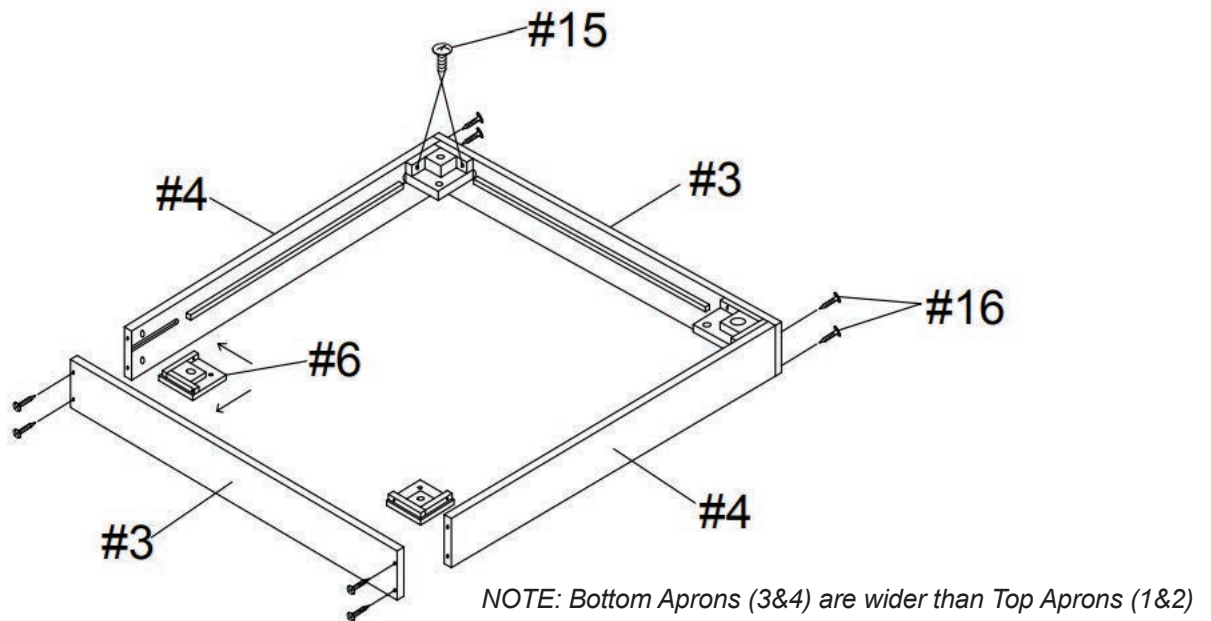

ASSEMBLY INSTRUCTIONS (CONT.)

STEP 3

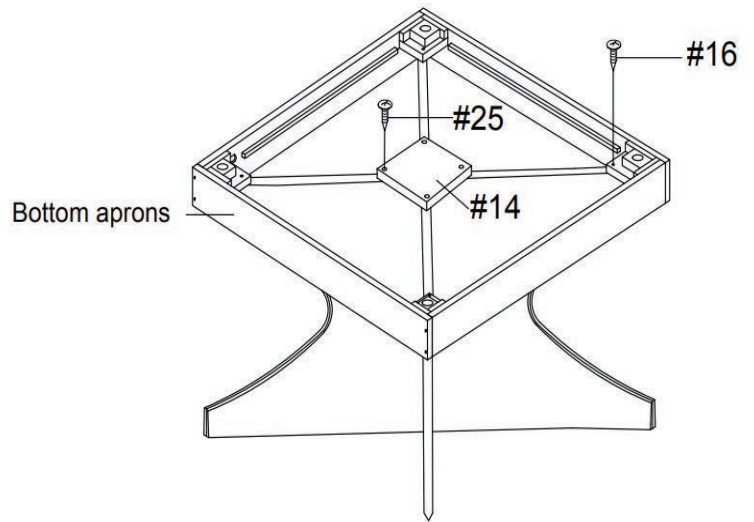
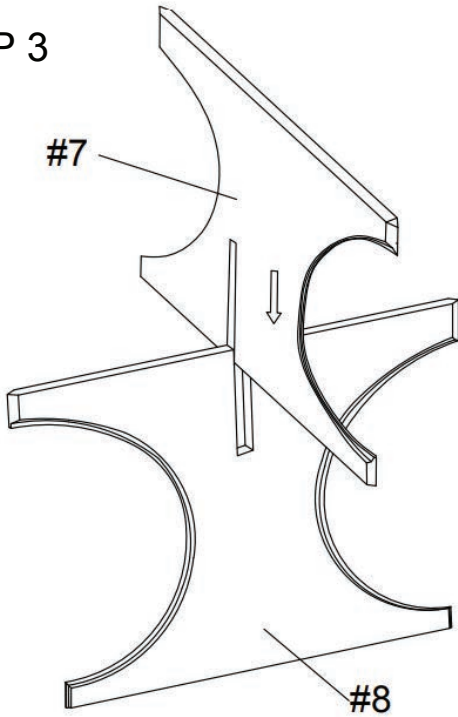

STEP 4

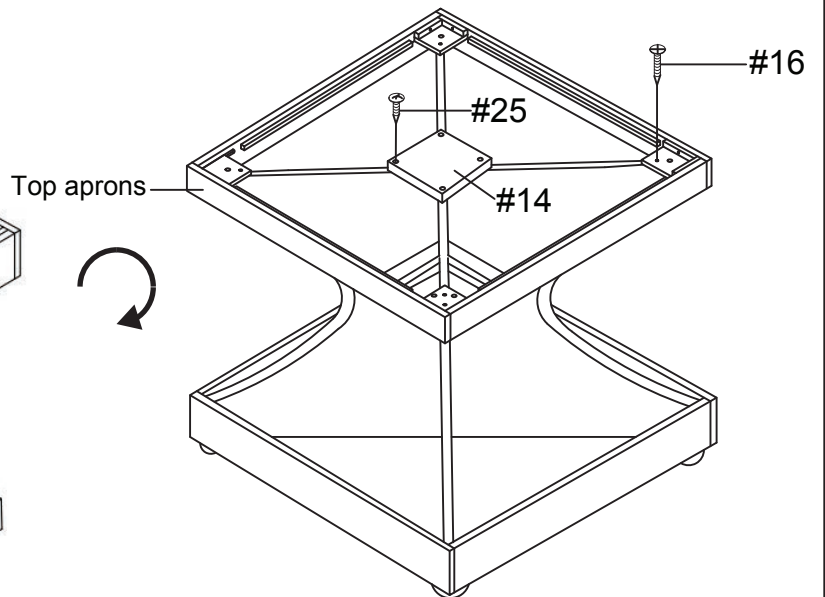
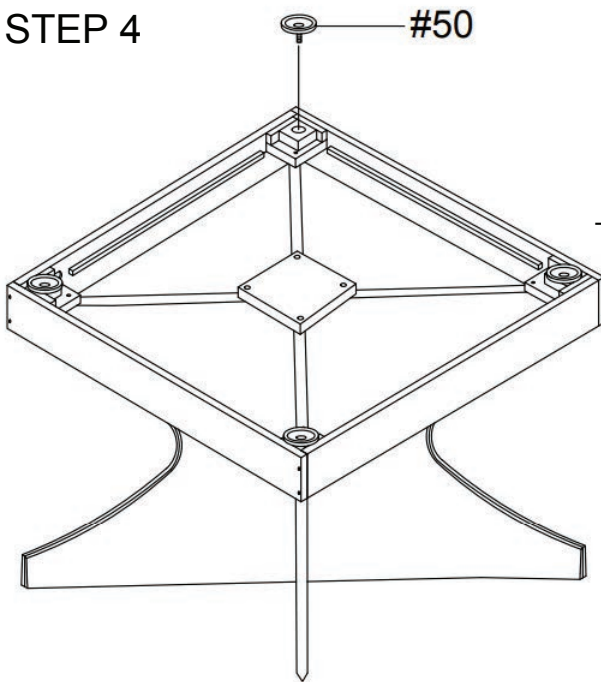

ASSEMBLY INSTRUCTIONS (CONT.)

STEP 5

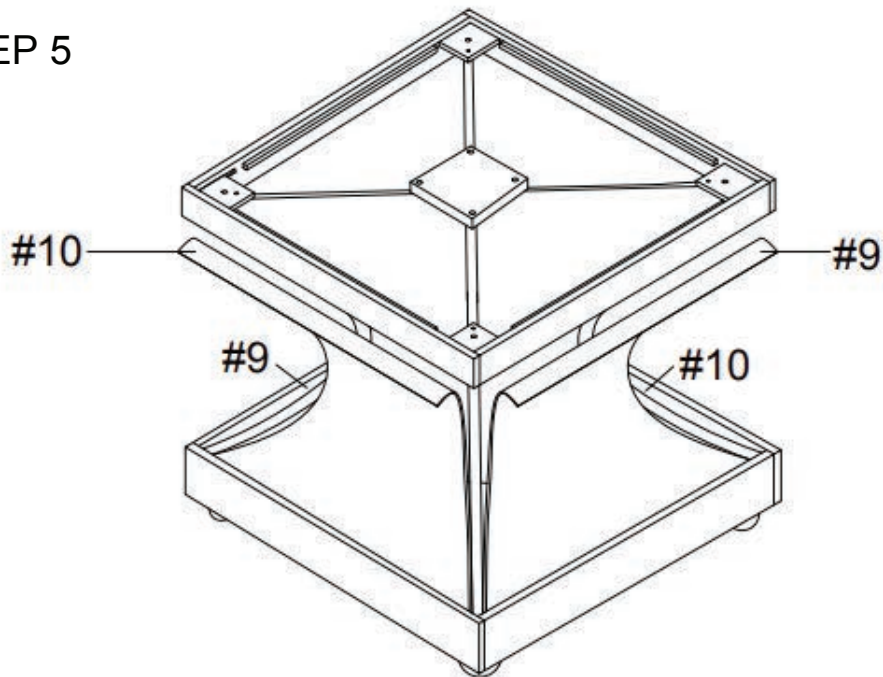

Caution:
Insert the leg panel into the
slot of the bottom aprons,
and then push the leg panel
into the top aprons!

*NOTE: To attach the Leg Panels (9&10) insert panel bottom inside bottom apron, making sure it is **centered** in opening, and flex middle of panel in until top fits **centered** inside top apron.*

STEP 6

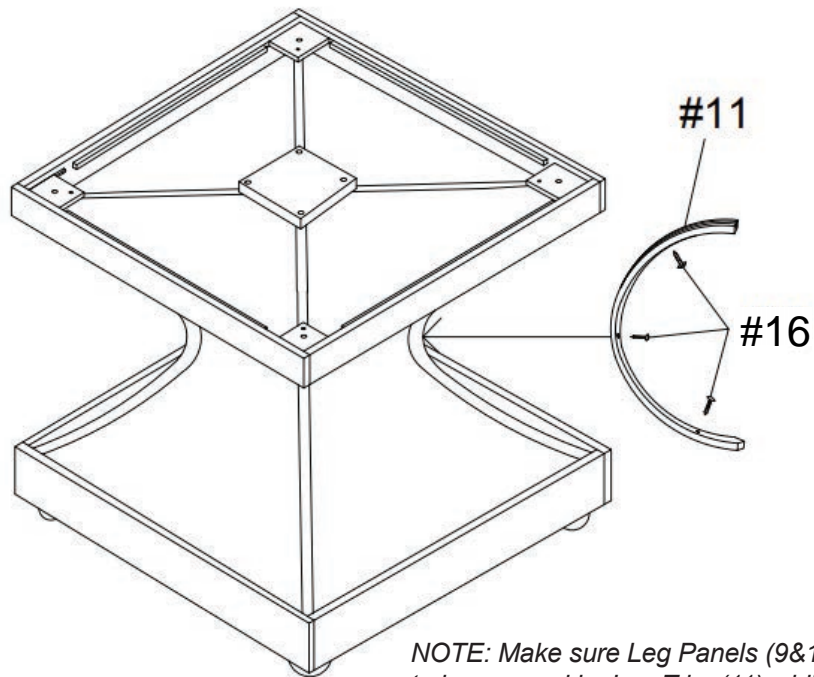

*NOTE: Make sure Leg Panels (9&10) are pushed in enough
to be covered by Leg Trim (11) while securing with Screws (16).*

ASSEMBLY INSTRUCTIONS (CONT.)

STEP 7

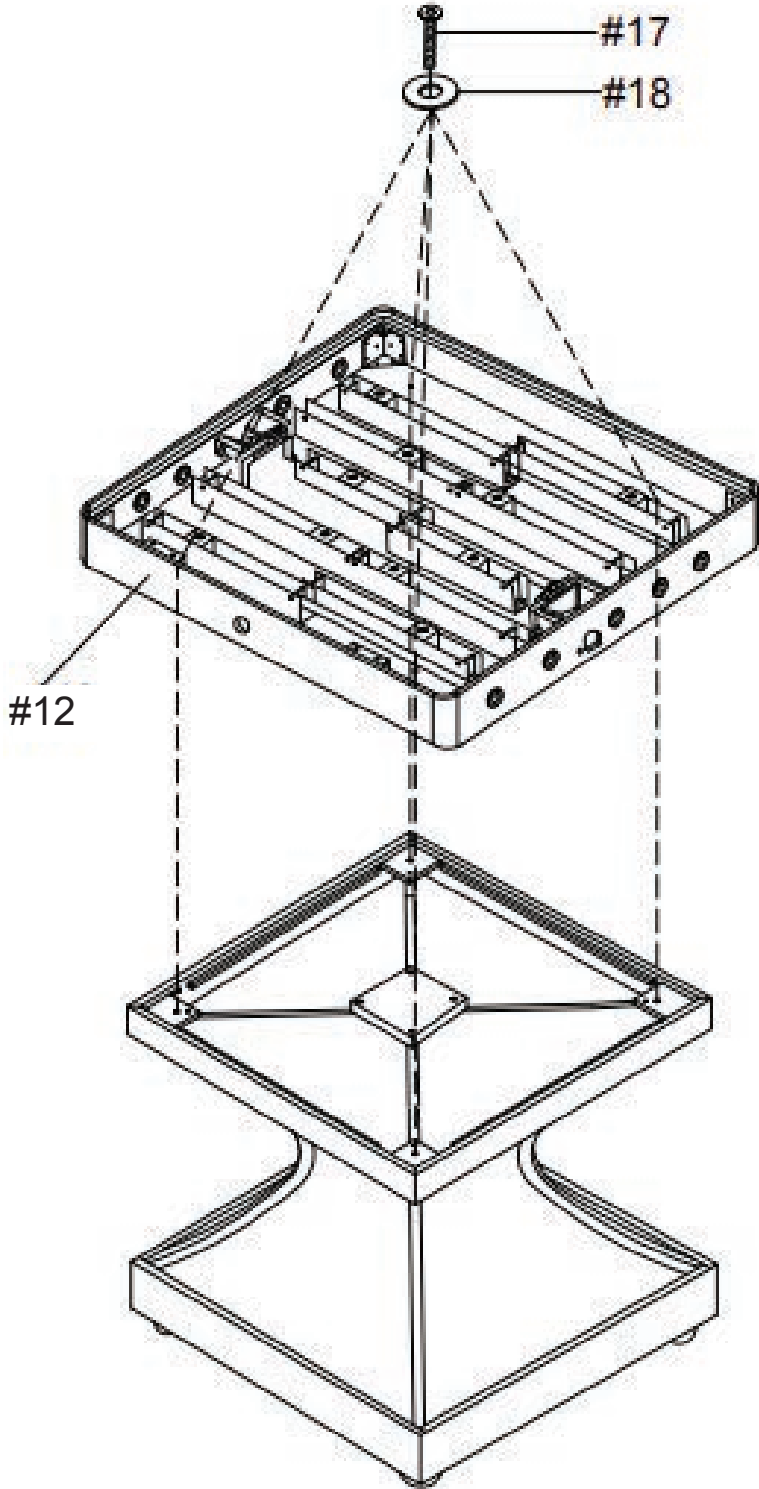

ASSEMBLY INSTRUCTIONS (CONT.)

STEP 8

NOTE: Insert all player rods in correct location as indicated below and add springs as shown to right.

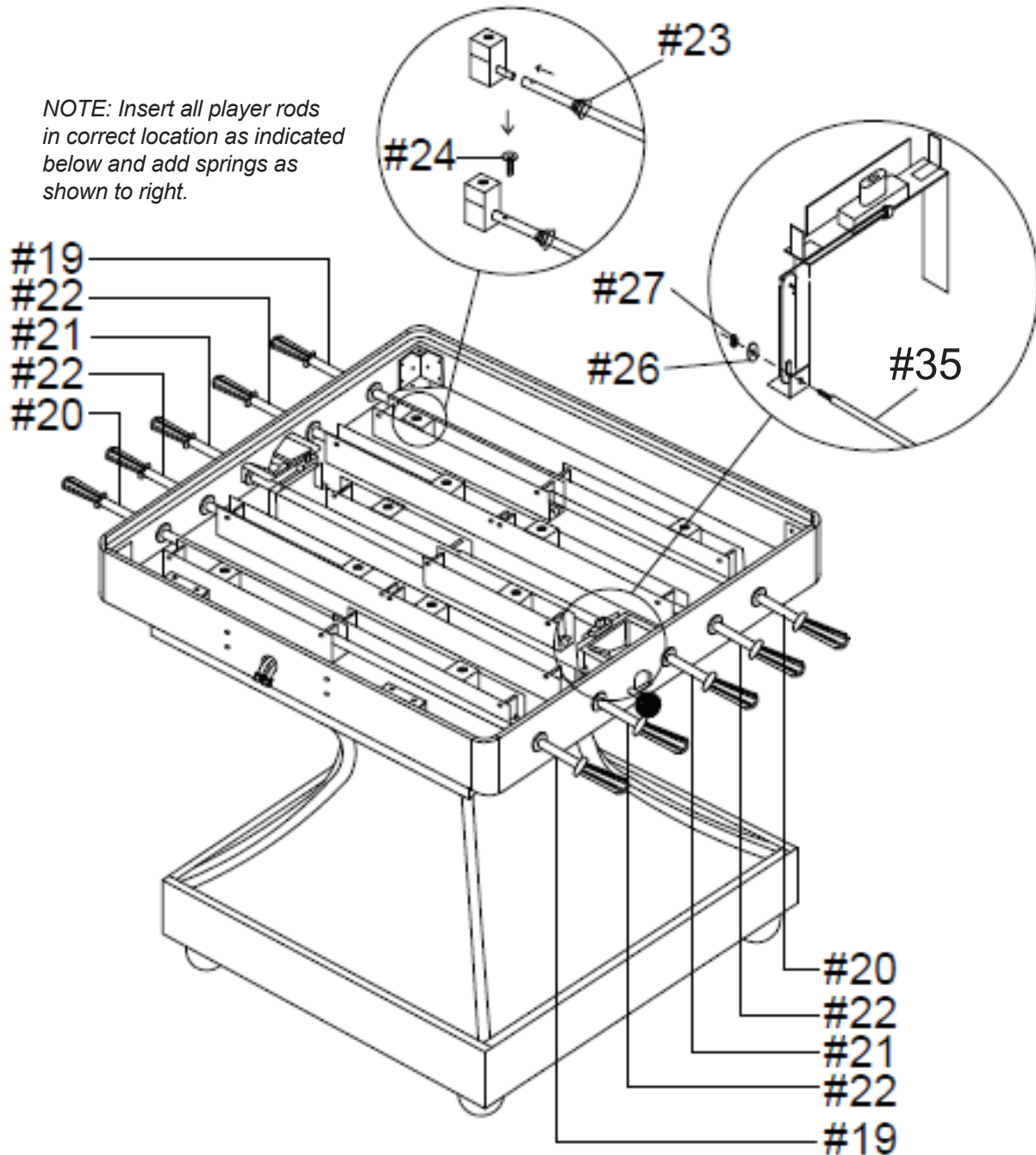

ASSEMBLY INSTRUCTIONS (CONT.)

STEP 9

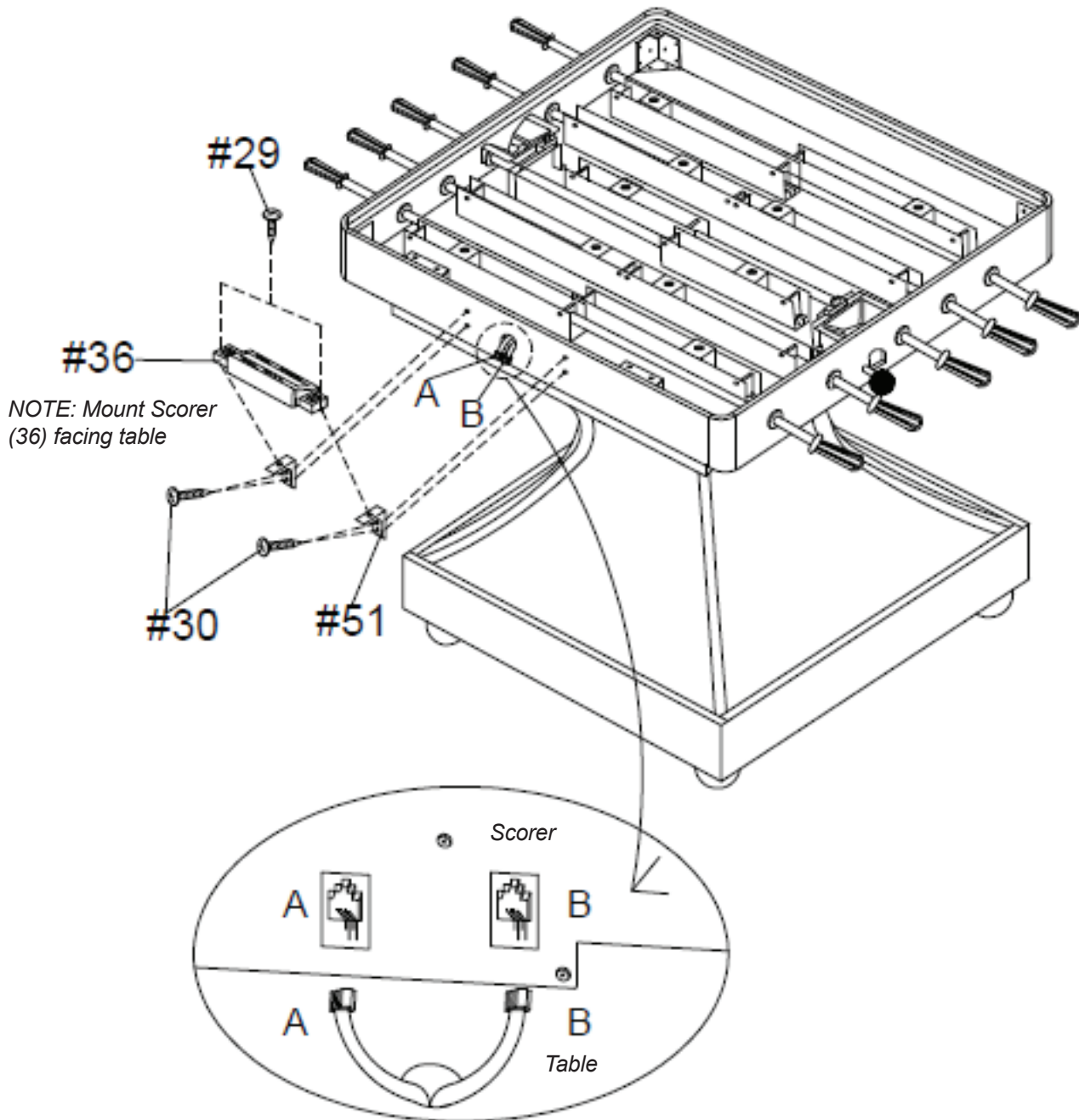

ASSEMBLY INSTRUCTIONS (CONT.)

STEP 10

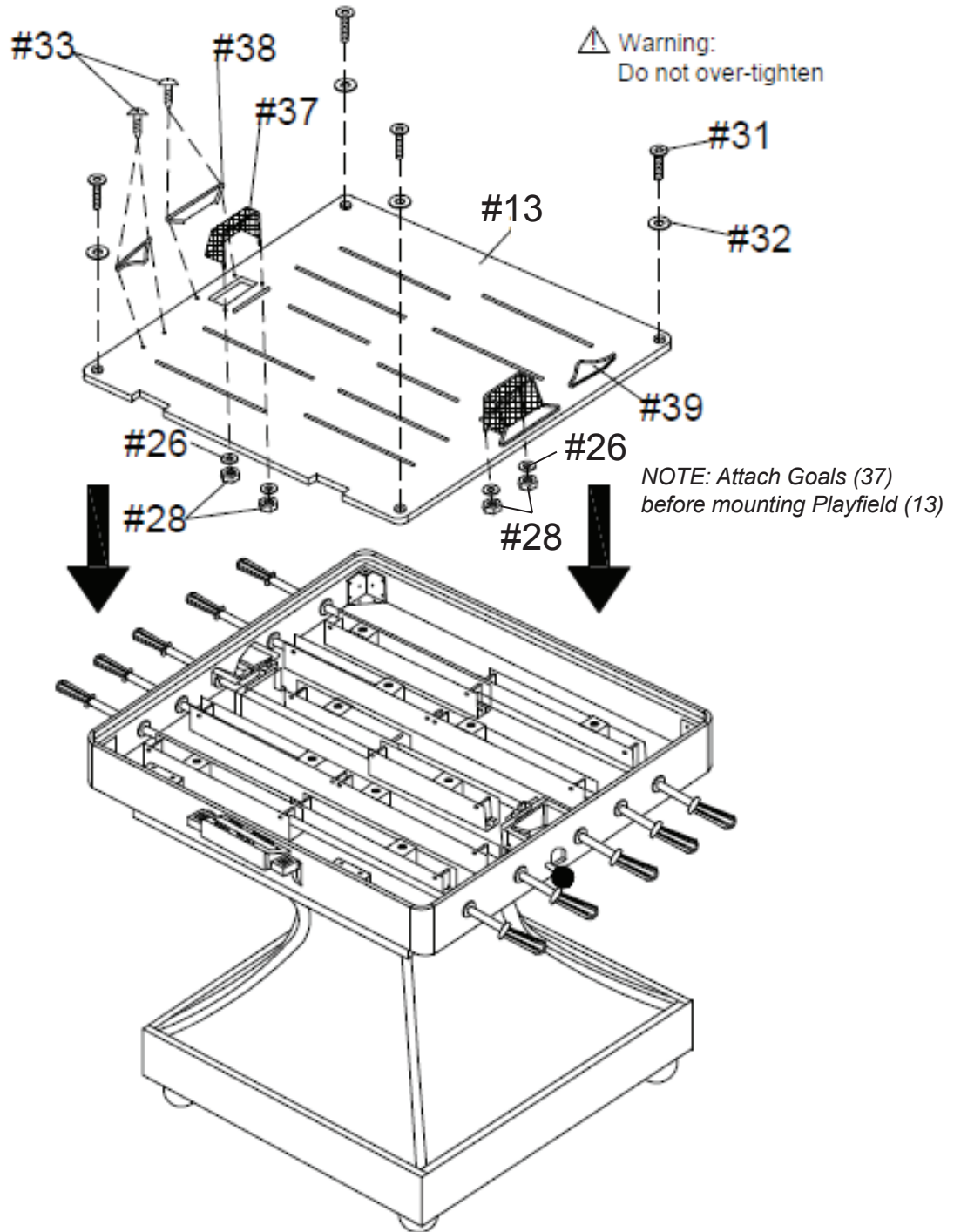

ASSEMBLY INSTRUCTIONS (CONT.)

STEP 11

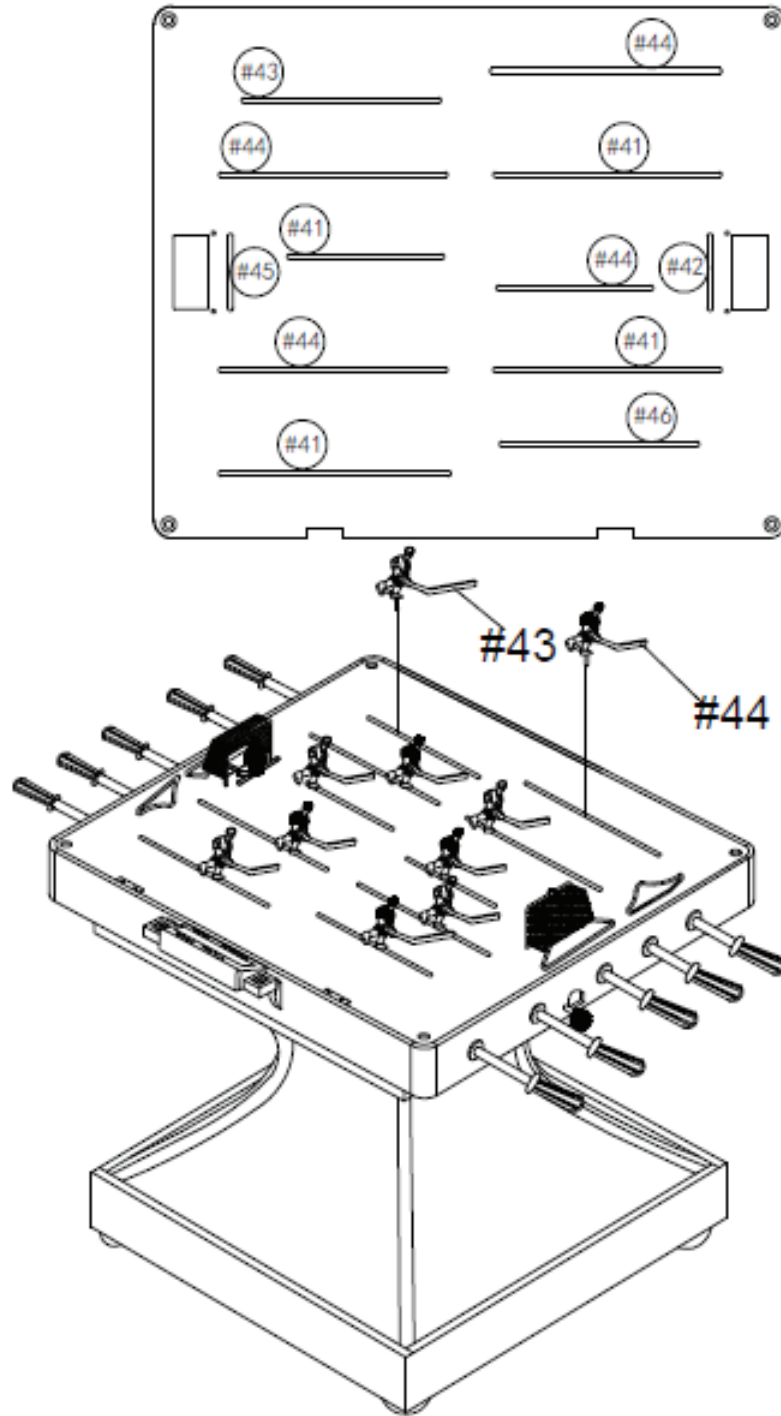

ASSEMBLY INSTRUCTIONS (CONT.)

STEP 12

⚠ CAUTION:
Keep the clear dome at 60 degrees
and hold it when you open it!

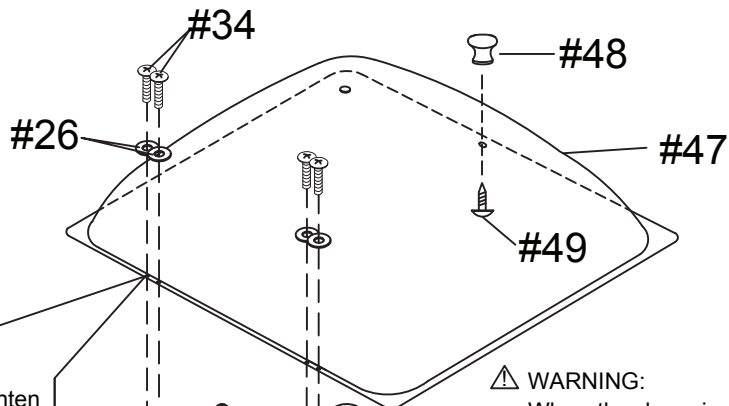
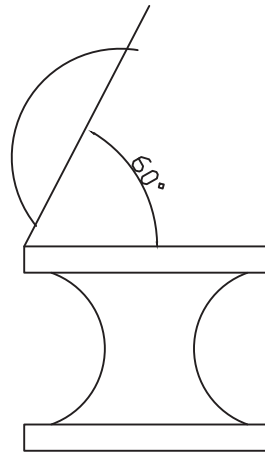

⚠ CAUTION:
Do not over-tighten
screws as you can
crack the dome

⚠ WARNING:
When the dome is open
it must be supported by an adult
at all times to avoid damage or injury

NOTE: Electrical Adapter (52)
plugs into back of Scorer (36)
OR optionally insert 4 AA
batteries (not included) in
scorer battery compartment.
Remove any batteries when
using adapter.

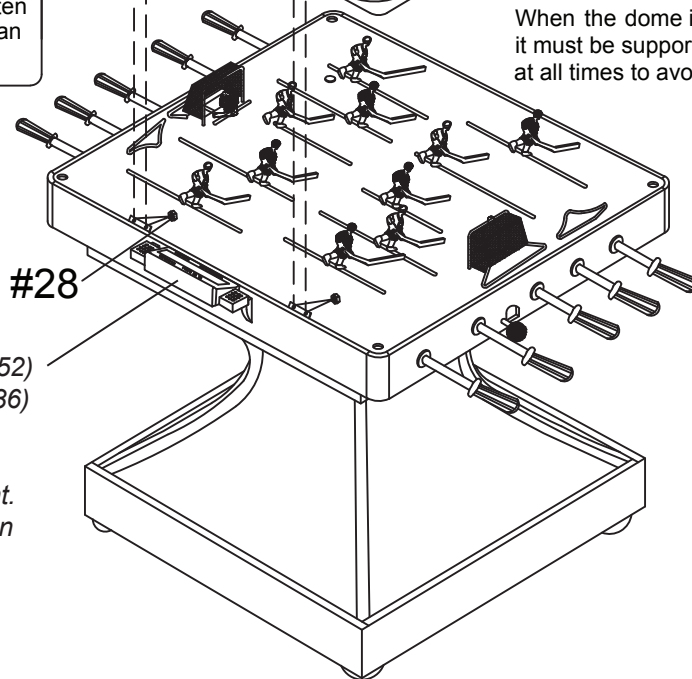

180-DAY LIMITED WARRANTY

This product is warranted to the original purchaser to be free from defects in material or workmanship for a period of 180 days from the date of the original retail purchase.

This warranty does not cover defects or damage due to improper installation, alteration, accident or any other event beyond the control of the manufacturer. Defects or damage resulting from misuse, abuse or negligence will void this warranty. This warranty does not cover scratching or damage that may result from normal usage.

This product is not intended for institutional or commercial use; the manufacturer does not assume any liability for such use. Institutional or commercial use will void this warranty.

This warranty is nontransferable and is expressly limited to the repair or replacement of the defective product. During the warranty period, the manufacturer shall repair or replace defective parts at no cost to the purchaser. Shipping charges and insurance are not covered and are the responsibility of the purchaser. Labor charges and related expenses for removal, installation or replacement of the product or components are not covered under this warranty.

The manufacturer reserves the right to make substitutions to warranty claims if parts are unavailable or obsolete.

The manufacturer shall not be liable for loss of use of the product or other consequential or incidental costs, expenses or damages incurred by the consumer of any other use. The user assumes all risk of injury resulting from the use of this product.

This warranty is expressly in lieu of all other warranties, expressed or implied, including warranties of merchantability or fitness for use to the extent permitted by Federal or state law. Neither the manufacturer nor any of its representatives assumes any other liability in connection with this product.

All warranty claims must be made through the retailer where the product was originally purchased. A purchase receipt or other proof of date of purchase will be required to process all warranty claims. The model number and part numbers found within the assembly instructions will be required when submitting any parts requests or warranty claims.

For further warranty information or inquiries, please call 800-759-0977



Designed for Fun, Built to Last®

TABLE DE HOCKEY EN DÔME BREAKAWAY 104 cm INSTRUCTIONS D'ASSEMBLAGE



Contactez notre
service à la clientèle au
800-759-0977
avec des questions sur le montage
ou l'utilisation de ce produit.

MERCI!

Merci d'avoir acheté notre produit. Nous travaillons 24 heures sur 24, partout dans le monde, à garantir que nos produits sont de la meilleure qualité possible. Toutefois, dans les rares cas de problèmes lors du montage ou de l'utilisation de ce produit, se il vous plaît communiquer avec notre service à la clientèle au **800-759-0977** pour une aide immédiate avant de contacter votre revendeur. Pour obtenir de plus amples renseignements, veuillez lire l'information relative à la garantie au verso de ce guide d'instructions.

INSTRUCTIONS D'ASSEMBLAGE

IMPORTANT! VEUILLEZ LIRE, EN ENTIER, TOUTES LES INSTRUCTIONS AVANT D'ASSEMBLER VOTRE PRODUIT.

1. Trouver une surface propre et plane, pour commencer le montage de votre table de jeu. La table s'assemble à l'envers pour être ensuite retournée sur ses pieds, une fois l'assemblage complété. Cette table est lourde et nécessite au moins deux adultes forts pour la soulever et la retourner.
2. Retirez le contenu de la boîte, avant de commencer l'assemblage, assurez-vous d'avoir toutes les pièces telles que listées et illustrées au tableau d'identification. **Avis : certaines pièces sont préassemblées ou préinstallées.**
3. Certaines illustrations ou dessins peuvent ne pas ressembler au produit que vous avez acheté.
4. **Quand vous fixez en place une pièce avec plus d'une vis ou écrou, veuillez, en premier, les visser à la main et terminer la fixation avec un tournevis ou une clé.**
5. Un tournevis électrique peut être utile lors de l'assemblage, mais veuillez le régler à **basse torque** et l'utiliser avec prudence; si la torque est trop élevée, la vis peut se défaire ou être trop serrée.



ENTRETIEN ET USAGE

1. Ce produit doit être utilisé **À L'INTÉRIEUR** seulement.
2. **NE JAMAIS** déplacer la table en la traînant, cela pourrait endommager les pieds.

TABLE DE HOCKEY EN DÔME BREAKAWAY - BG5003

Liste des pièces

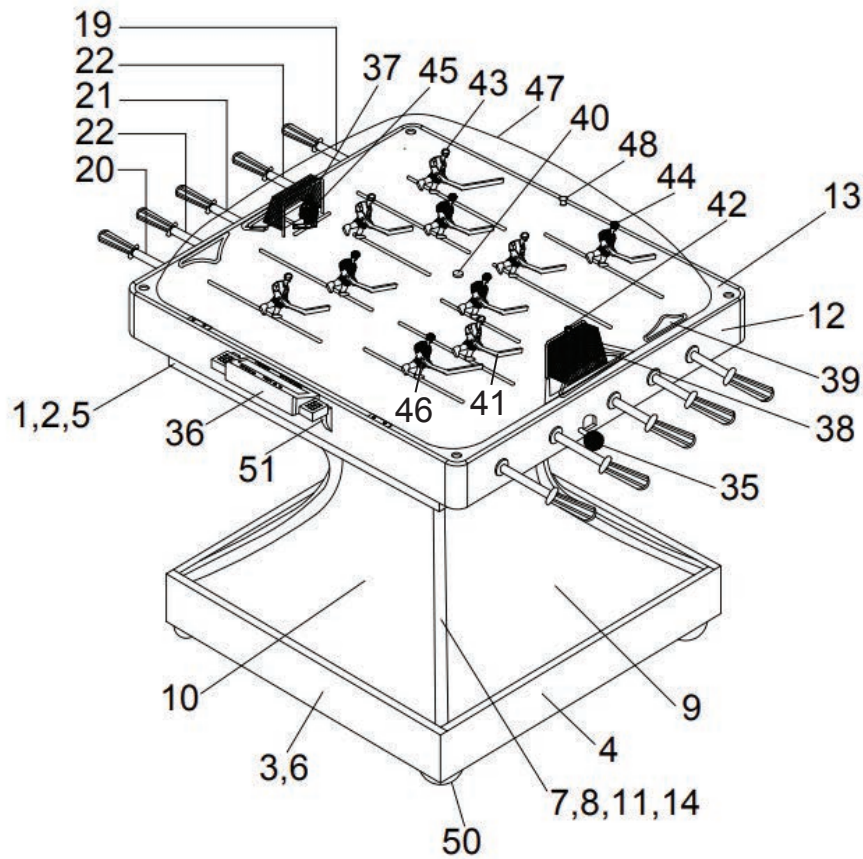

illustrations non à l'échelle

PIÈCES











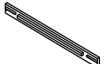
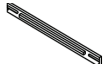

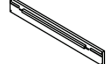



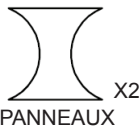
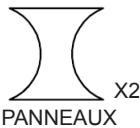

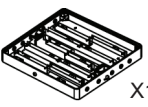

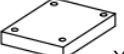





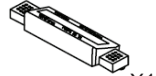

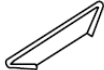



#1 NGP7113  X2 TABLIER SUPÉRIEUR A	#2 NGP7114  X2 TABLIER SUPÉRIEUR B	#3 NGP7115  X2 TABLIER INFÉRIEUR A	#4 NGP7116  X2 TABLIER INFÉRIEUR B	#5 NGP7117  X4 CARTE DE CONNEXION SUPÉRIEUR	#6 NGP7118  X4 CARTE DE CONNEXION INFÉRIEUR	#7 NGP7119  X1 TRAVERSE A
#8 NGP7120  X1 TRAVERSE B	#9 NGP7122  X2 PANNEAUX DE PIED A	#10 NGP7123  X2 PANNEAUX DE PIED B	#11 NGP7124  X4 BORDURE DE PIED	#12 NGP7125  X1 ARMOIRE SUPÉRIEUR	#13 NGP7126  X1 TERRAIN DE JEU	#14 NGP7121  X2 PLAQUE DE SUPPORT
#19 NGP7127  X2 TIGE LONGUE	#20 NGP7128  X2 TIGE MILIEU A	#21 NGP7129  X2 TIGE MILIEU B	#22 NGP7130  X4 TIGE COURTE	#23 NGP7131  X10 RESSORT DE TIGE	#35 NGP7132  X2 CONTRÔLE DES GARDIENS	#36 NGP7133  X1 MARQUEUR ÉLECTRONIQUE







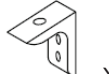











TABLE DE HOCKEY EN DÔME BREAKAWAY - BG5003

Liste des pièces

PIÈCES

#37 NGP7134  X2 BUT	#38 NGP7135  X2 BUTOIR DE TERRAIN DE JEU DE BUT	#39 NGP7136  X2 BUTOIR DE TERRAIN DE JEU	#40 NGP7102  X2 PALET	#41 NGP7138  X4 JOUEUR DE BÂTON COURT ROUGE	#42 NGP7139  X1 GARDIEN DE BUT ROUGE	#43 NGP7140  X1 JOUEUR DE BÂTON LONGUE ROUGE
#44 NGP7141  X4 JOUEUR DE BÂTON COURT BLEU	#45 NGP7142  X1 GARDIEN DE BUT BLEU	#46 NGP7143  X1 JOUEUR DE BÂTON LONGUE BLEU	#47 NGP7144  X1 DÔME	#48 NGP7145  X1 POIGNÉE DE DÔME	#50 NGP7146  X4 PATIN DE NIVELLEMENT	#51 NGP7147  X2 MARQUEUR L-SUPPORT
#52 NGP7103  X1 ADAPTATEUR ÉLECTRIQUE	#55 NGP7104 élément de la surface de jeu (A & B fils: 1 fil fixe par but) FIL DE CAPTEUR DE BUT					

SAC DE QUINCAILLERIE - NGP7148

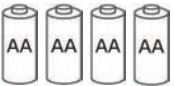
#15 X16  VIS	#16 X32  VIS	#17 X4  BOULON	#18 X4  RONDELLE	#24 X10  BOULON	#25 X8  VIS	#26 X10  RONDELLE
#27 X2  ÉCROU	#28 X8  ÉCROU	#29 X2  VIS	#30 X4  VIS	#31 X4  BOULON	#32 X4  RONDELLE	#33 X12  VIS
#34 X4  BOULON	#49 X1  VIS	#53 X1  CLÉ HEXAGONALE	#54 X1  CLÉ	ÉQUIPEMENT ADDITIONNEL REQUIS  TOURNEVIS CRUCIFORME	ÉQUIPEMENT ADDITIONNEL REQUIS  4 PILES AA (NON INCLUS)	

INSTRUCTIONS D'ASSEMBLAGE

étape 1

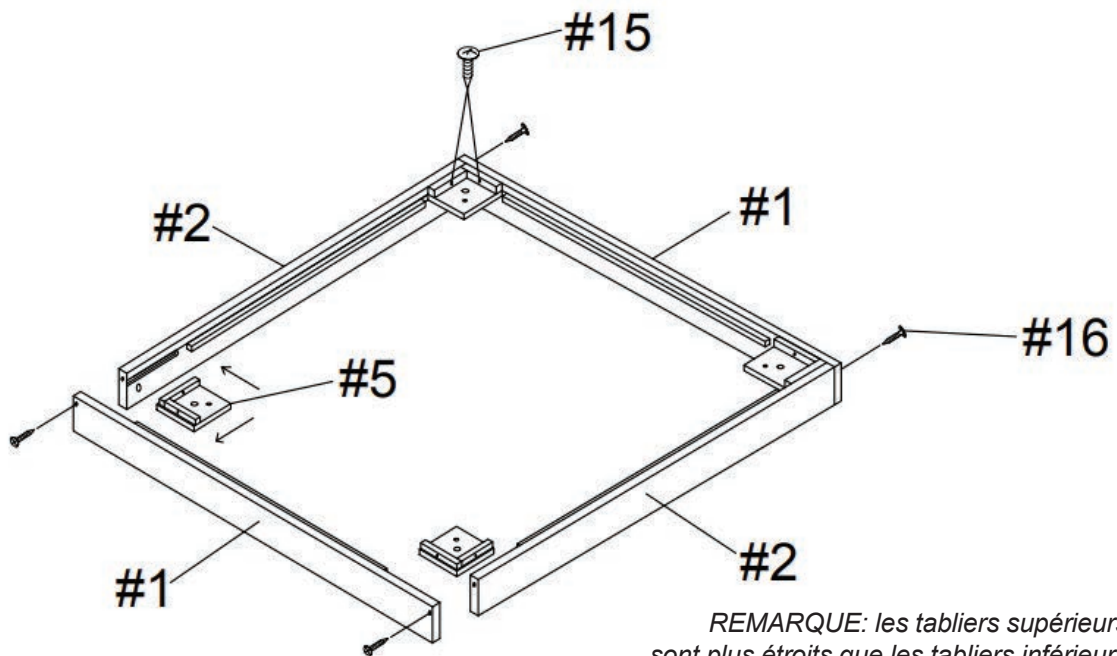

REMARQUE: les tabliers supérieurs (1 et 2)
sont plus étroits que les tabliers inférieurs (3 et 4)

étape 2

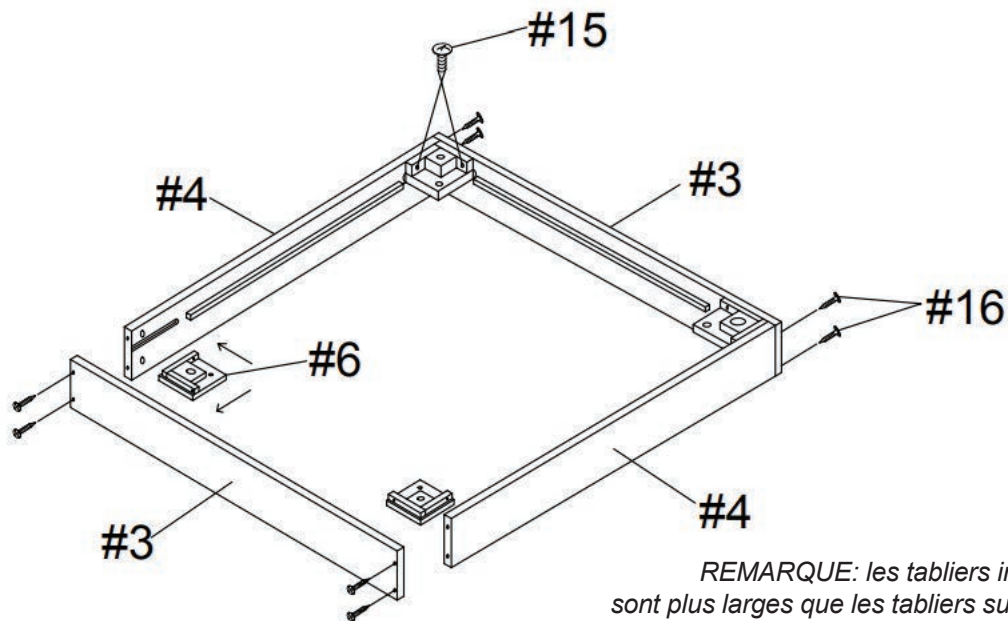

REMARQUE: les tabliers inférieurs (3 et 4)
sont plus larges que les tabliers supérieurs (1 et 2)

INSTRUCTIONS D'ASSEMBLAGE (suite)

étape 3

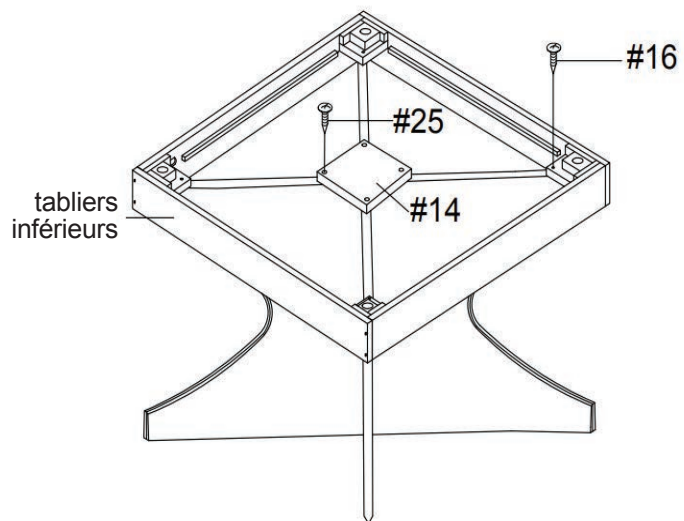
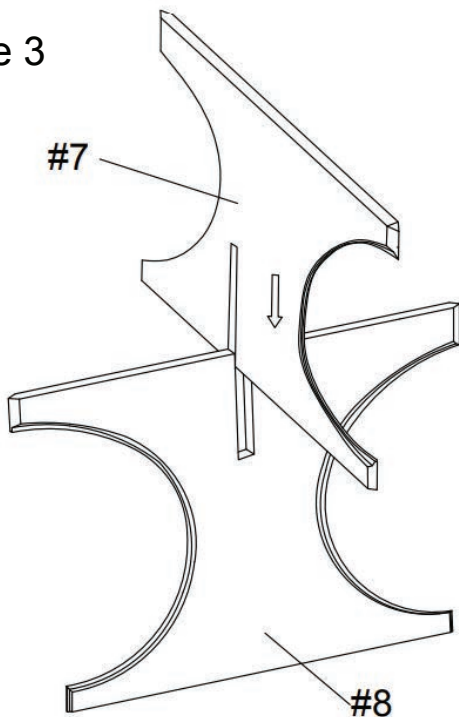

étape 4

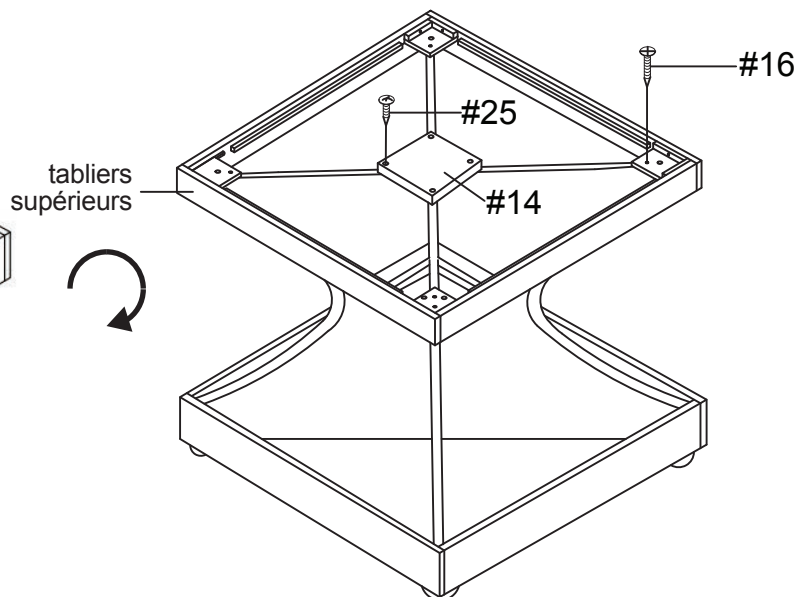
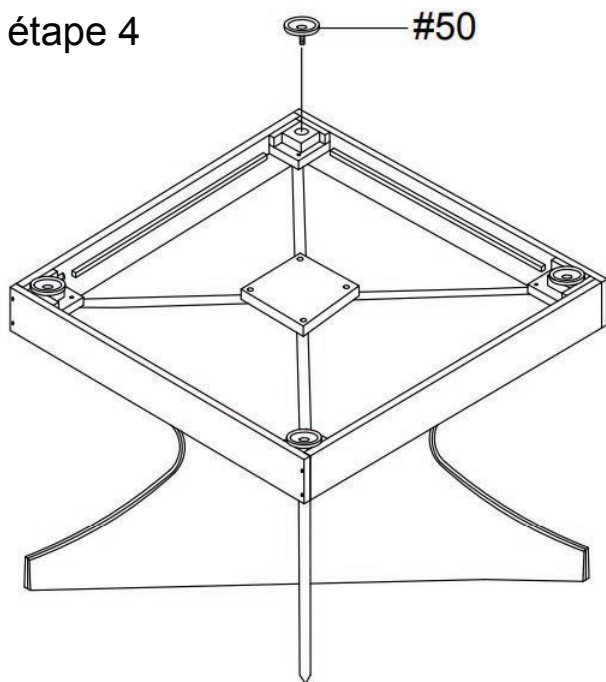

INSTRUCTIONS D'ASSEMBLAGE (suite)

étape 5

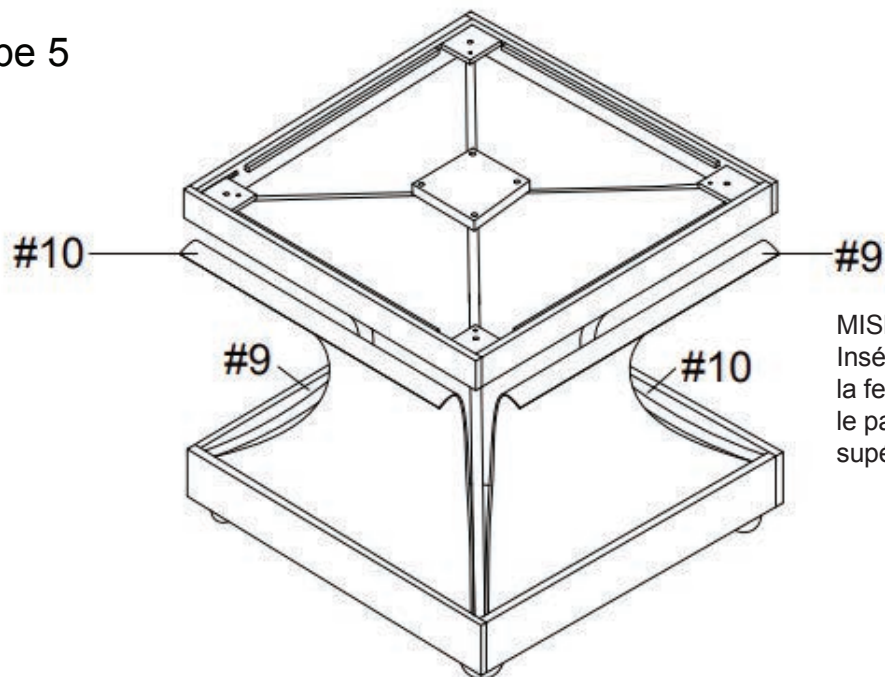

MISE EN GARDE:

Insérez le panneau de la jambe dans la fente du tablier inférieur, puis poussez le panneau de la pied dans les tabliers supérieurs.

*REMARQUE: Pour fixer les panneaux de pied (9 et 10), insérez le bas du panneau à l'intérieur du tablier inférieur, en vous assurant qu'il est **centré** dans l'ouverture et pliez le milieu du panneau jusqu'à ce que le dessus soit **centré**.*

étape 6

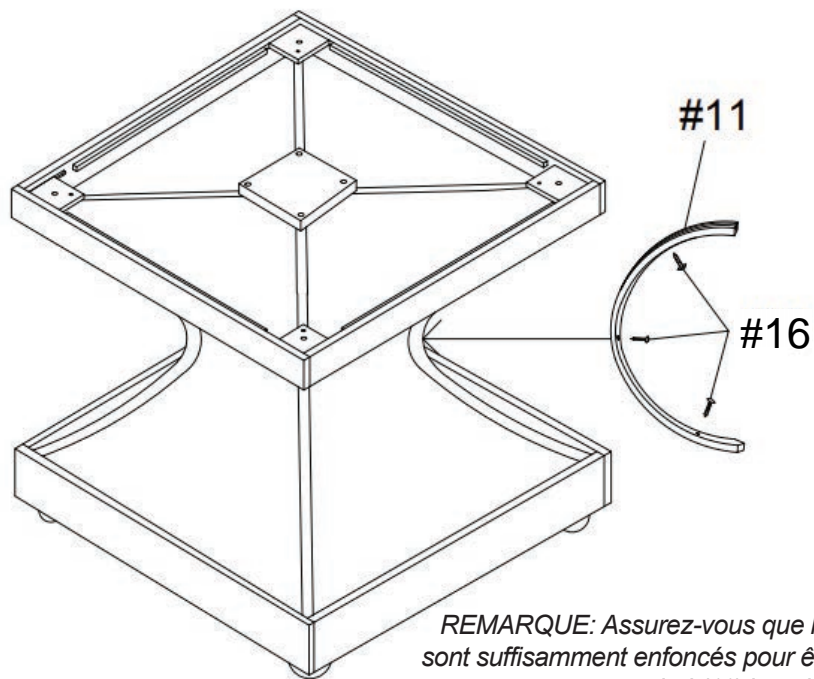

REMARQUE: Assurez-vous que les panneaux de pied (9 et 10) sont suffisamment enfoncés pour être couverts par la bordure de pied (11) lors de la fixation à l'aide de vis (16).

INSTRUCTIONS D'ASSEMBLAGE (suite)

étape 7

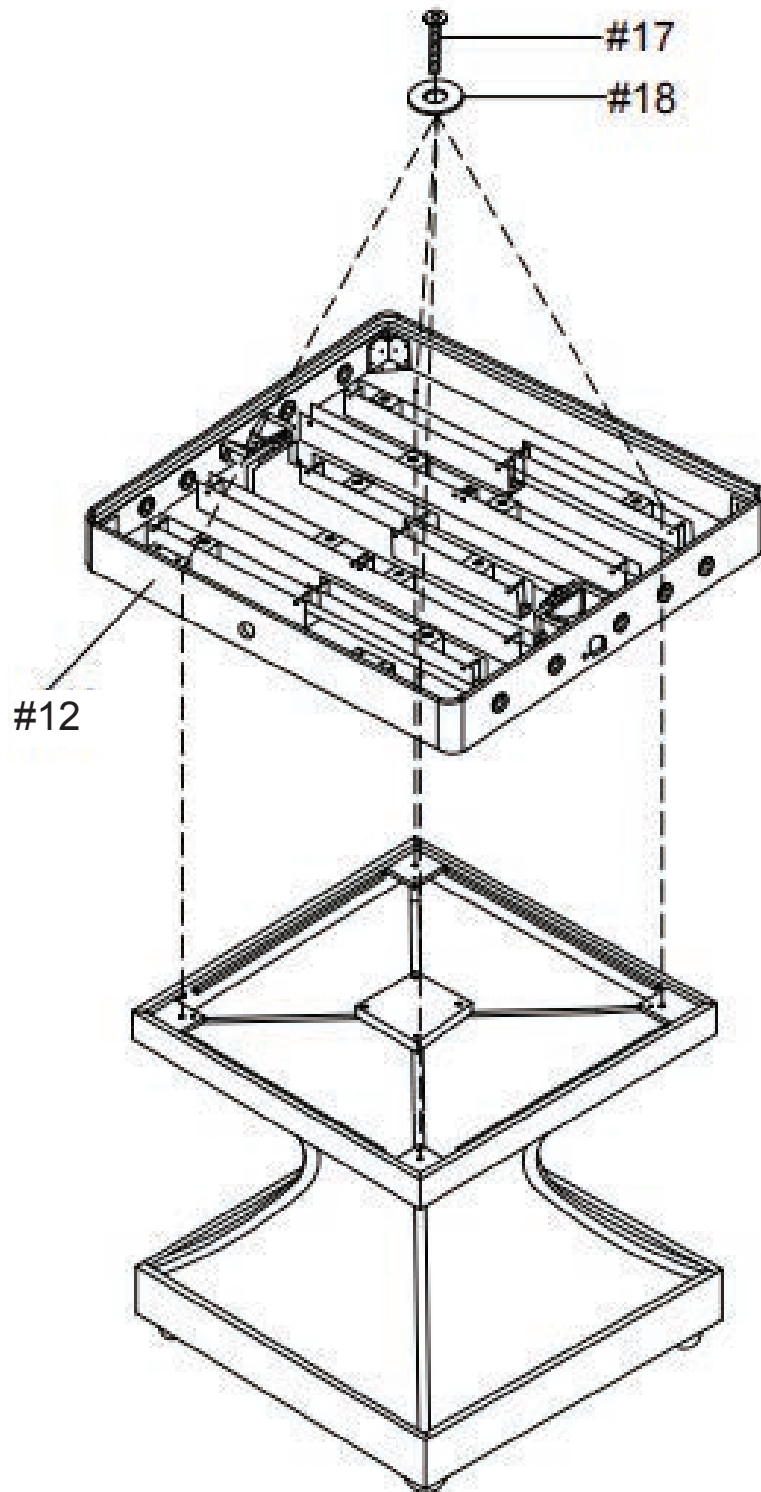

INSTRUCTIONS D'ASSEMBLAGE (suite)

étape 8

REMARQUE: Insérer toutes les tiges du lecteur au bon endroit, comme indiqué ci-dessous, et ajoutez des ressorts comme indiqué ci-contre.

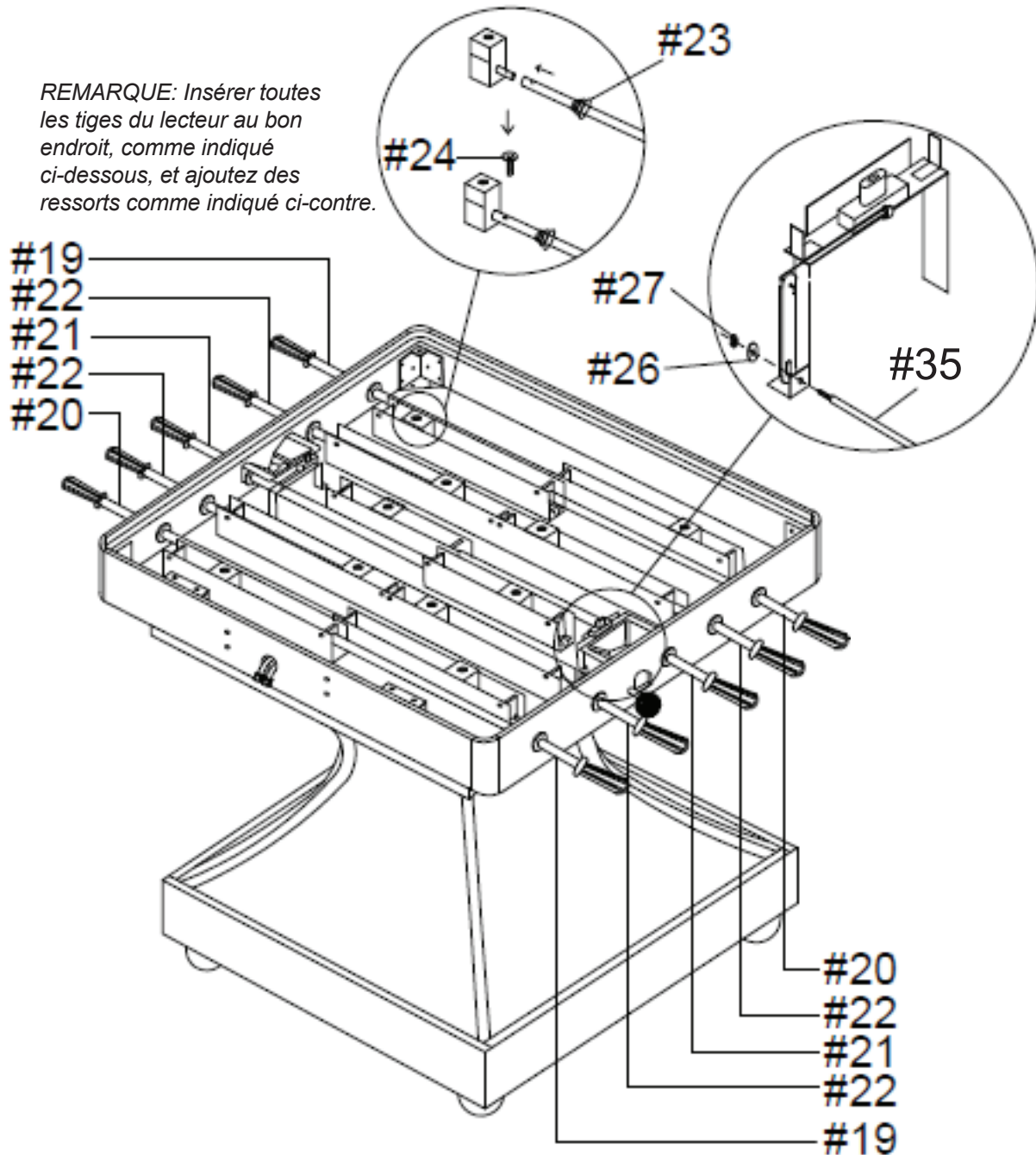

INSTRUCTIONS D'ASSEMBLAGE (suite)

étape 9

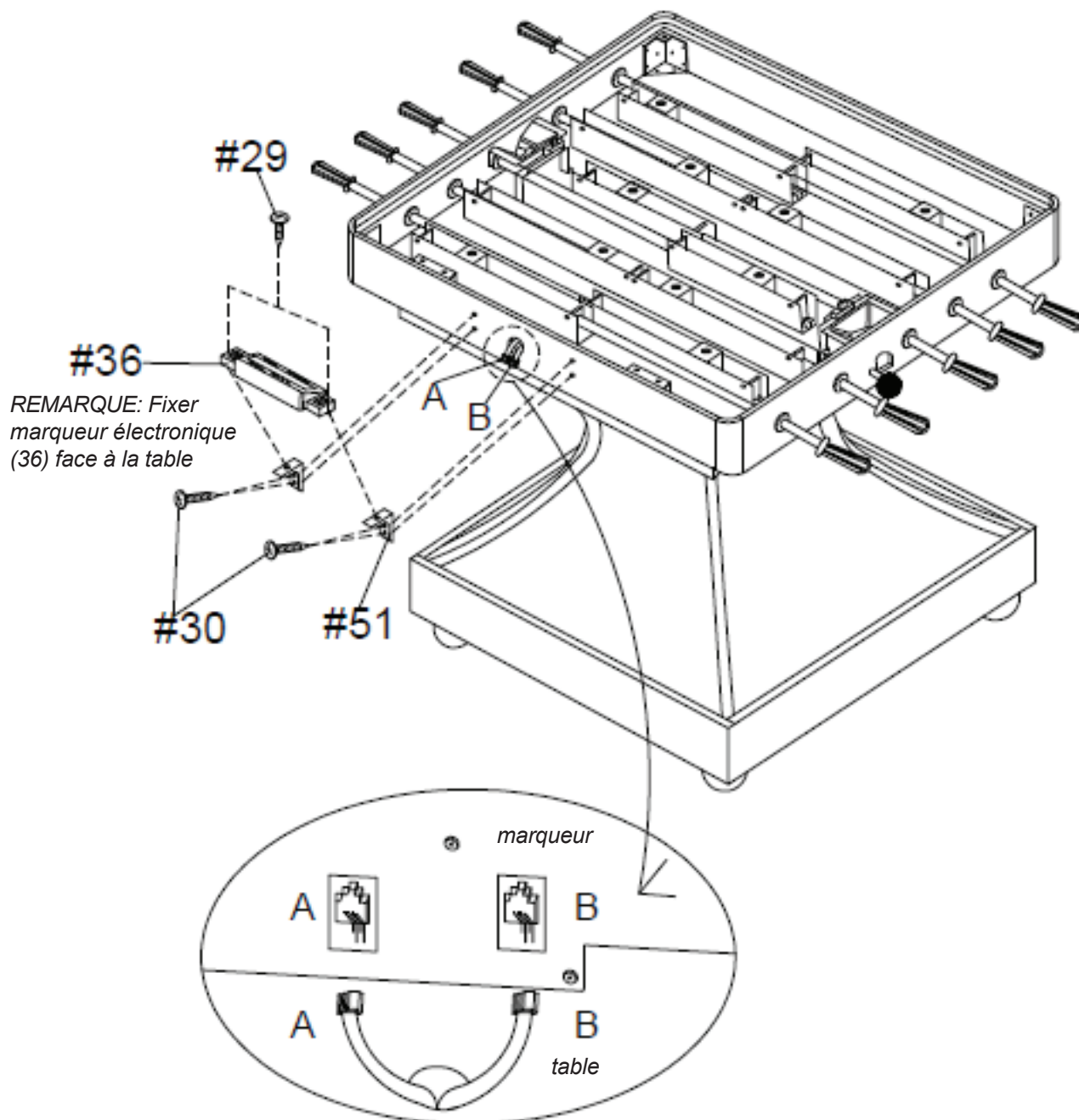

INSTRUCTIONS D'ASSEMBLAGE (suite)

étape 10

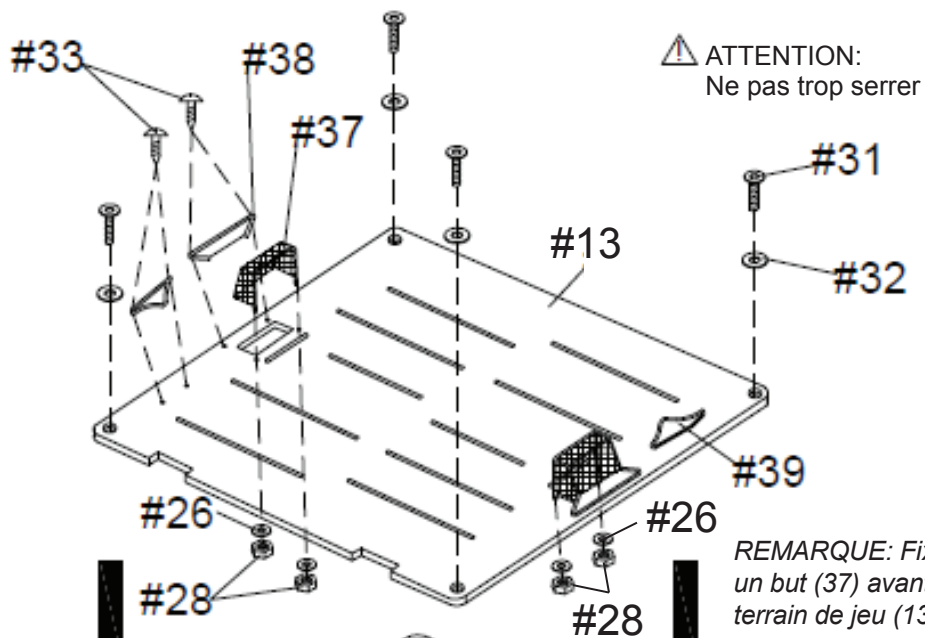

⚠ ATTENTION:
Ne pas trop serrer

REMARQUE: Fixer les marquer
un but (37) avant de montage
terrain de jeu (13).

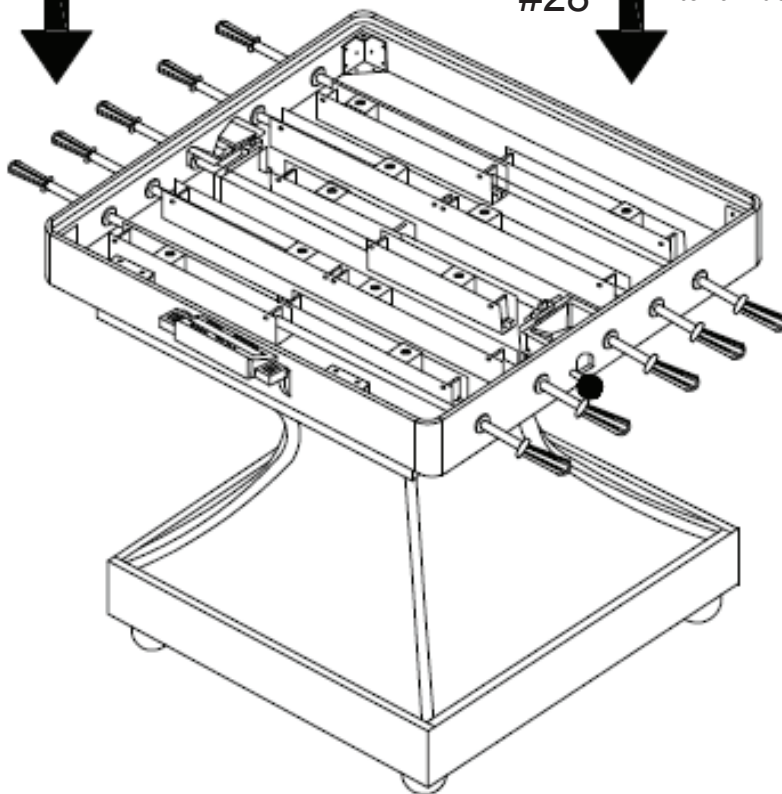

INSTRUCTIONS D'ASSEMBLAGE (suite)

étape 11

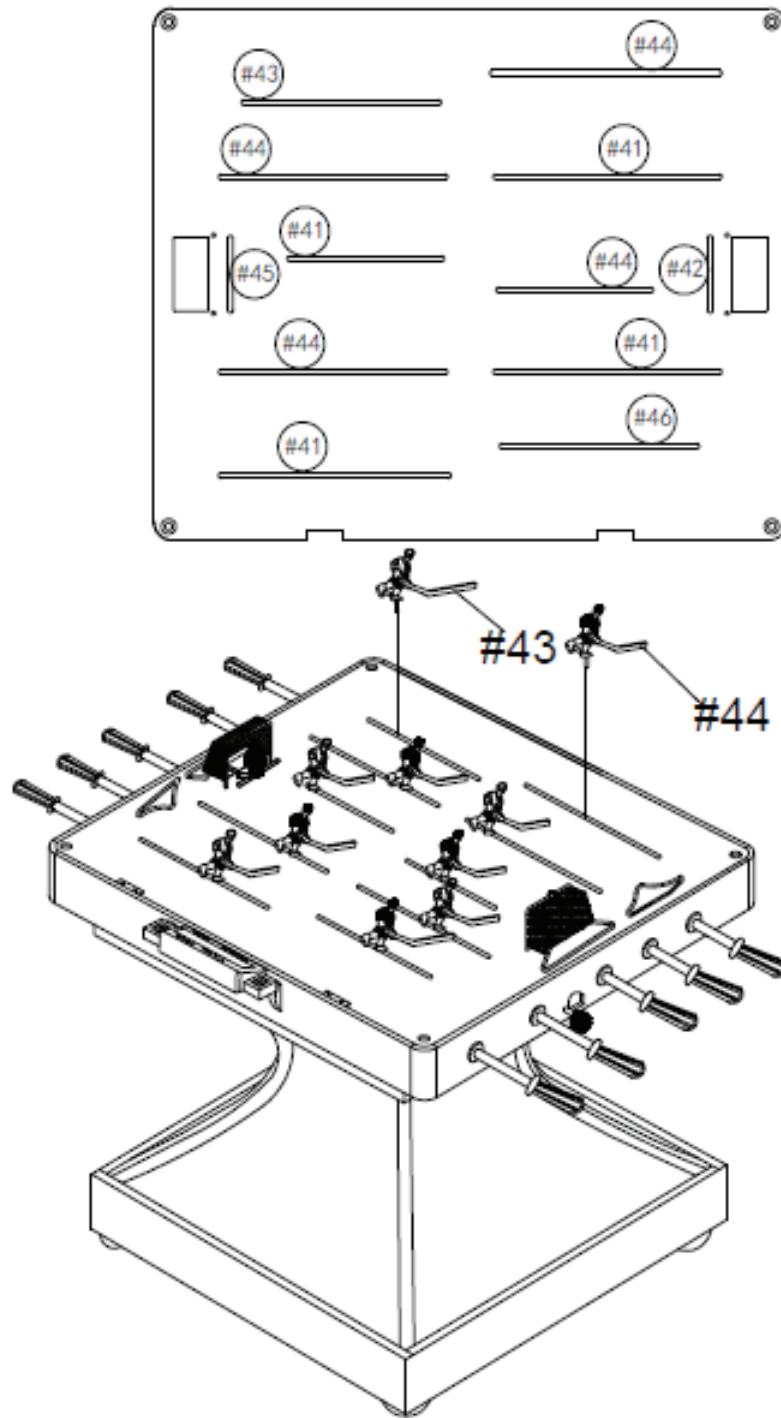

INSTRUCTIONS D'ASSEMBLAGE (suite)

étape 12

⚠ AVERTISSEMENT:
Gardez le dôme clair à 60 degrés
et maintenez-le lorsque vous l'ouvrez!

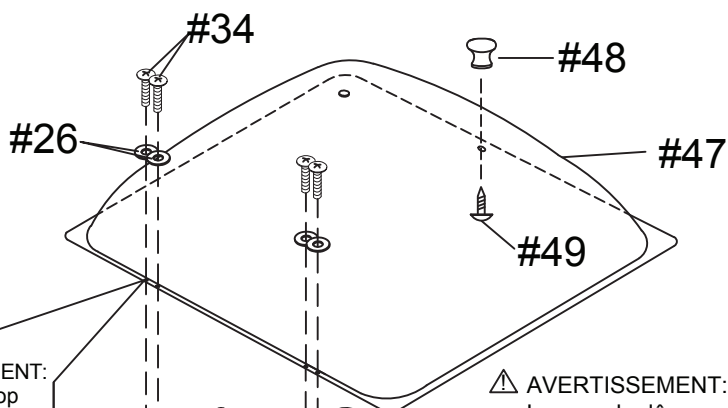
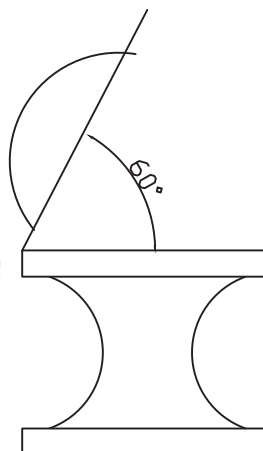

⚠ AVERTISSEMENT:
Ne serrez pas trop
les vis car vous
pourriez craquer
le dôme

⚠ AVERTISSEMENT:
Lorsque le dôme est ouvert, il doit être
soutenu en permanence par un adulte pour
éviter tout dommage ou blessure.

*REMARQUE: Adaptateur électrique (52)
se branche à l'arrière du marqueur
électronique (36) OU éventuellement
insérer 4 AA piles (non incluses)
dans marqueur électronique le
compartiment des piles. Retirez les
piles lorsque vous utilisez l'adaptateur.*

GARANTIE LIMITÉE DE 180 JOURS

La garantie du produit est valide pour l'acheteur original en ce qui a trait aux pièces défectueuses ou à la main-d'œuvre pour une période de 180 jours de la date d'achat.

Cette garantie n'est couverte pas les dommages causés par accident, par modification, par une installation défectueuse ou tout autre événement hors du contrôle du fabricant. Tout défaut ou dommage résultant de la négligence ou d'une mauvaise utilisation annule cette garantie. La présente garantie ne couvre pas les égratignures ou les dommages attribuables à un usage normal.

Ce produit n'est pas destiné à un usage institutionnel ou commercial; le fabricant décline toute responsabilité pour une telle utilisation. Un usage institutionnel ou commercial annule cette garantie.

Cette garantie est non transférable et est expressément limitée à la réparation ou au remplacement du produit défectueux. Au cours de la période de garantie, le fabricant s'engage à remplacer et à réparer les pièces défectueuses sans frais pour l'acheteur. Les frais d'assurance et d'expédition ne sont pas couverts et sont à la charge de l'acheteur. Les frais de main-d'œuvre et les dépenses liées au déplacement, à l'installation ou au remplacement du produit ou de ses composantes ne sont pas couverts par cette garantie.

Le fabricant se réserve le droit de faire des substitutions de recours en garantie si la pièce n'est pas disponible ou obsolète.

Le fabricant décline toute responsabilité liée à la perte d'utilisation ainsi que tous les autres coûts directs ou indirects, frais ou dommages encourus par le consommateur qui aurait été causés par une autre utilisation. L'utilisateur assume tous les risques de dommage résultant de l'utilisation de ce produit.

Cette garantie tient lieu expressément de toute autre garantie, exprimée ou implicite, y compris les garanties de qualité marchande ou d'adaptation à un emploi particulier dans la mesure permise par les lois fédérales ou provinciales. Ni le fabricant, ni aucun de ses représentants n'assument aucune autre responsabilité en rapport avec ce produit.

Toute réclamation doit être faite par le détaillant où le produit a été acheté. Une facture ou autre preuve d'achat est nécessaire pour traiter toutes les réclamations de garantie. Le numéro de modèle et les numéros de référence figurant dans les instructions d'assemblage seront exigés lors de la soumission de demande de pièces ou de recours en garantie.

Pour plus d'information ou pour toute question, veuillez téléphoner au 1 800 759-0977.