

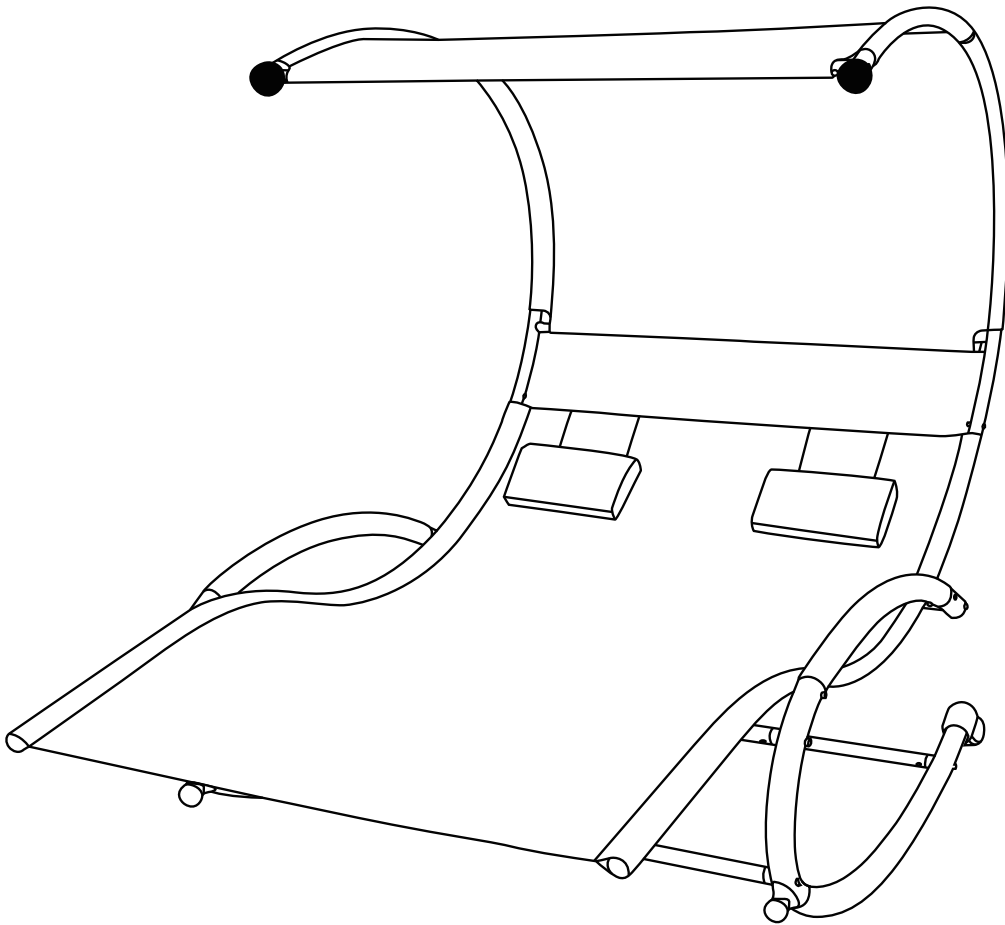

NU6902

COOL MESH SHADED DUAL LOUNGE

Assembly Instructions



Questions, problems, missing parts?

Before returning to your retailer, call our Consumer Hotline at 1-800-759-0977, Monday – Friday, 8 a.m. – 5 p.m. (CST).

THANK YOU!

Thank you for purchasing this product! We work around the clock and around the globe to ensure that our products maintain the highest possible quality. However, in the rare case of issues during assembly or use of this product, please contact our **Consumer Hotline** at **1-800-759-0977** for immediate assistance before contacting your retailer. Please read the warranty information at the back of this User Manual for further details.

⚠ SAFETY INFORMATION

Please read and understand this entire manual before attempting to assemble.

- Keep all children and pets away from assembly area. Children and pets should be supervised when they are in the area.
- Some parts may contain sharp edges. Wear protective gloves if necessary during assembly.
- When assembling and using this product, basic safety precautions should always be followed to reduce the risk of personal injury and damage to equipment. Please read all instructions before assembly and use.
- Check all bolts for tightness before and during usage.
- Please take time to read these instructions thoroughly and follow each step carefully for safe and easy operation. Keep this manual for future reference.



CARE AND MAINTENANCE

Our iron/steel components for products are coated with rust inhibiting paint that protects it from rusting. However, due to the nature of iron, surface oxidation (rusting) will occur once these protective coatings are scratched. This is a natural process and is not a defect! To minimize this condition, we recommend care when assembling & handling the product to prevent scratching the paint.

INSTALLATION AND ASSEMBLY

PARTS LIST

ITEM	PART DESCRIPTION	PART NUMBER	PART QTY
A	Rocker Leg	NUP4243	2
B	Leg Cross Brace	NUP4244	4
C	Front Side Support	NUP4245	2
D	Back Side Support	NUP4246	2
E	Fabric Seat	NUP4247	1
F	Bottom Awning Support	NUP4248	2
G	Top Awning Support	NUP4249	2
H	Fabric Awning	NUP4250	1
J	Awning Cross Brace	NUP4251	3
K	Pillow	NUP4252	2
L	End Cap	NUP4253*	2
M	Short Bolt		6
N	Medium Bolt		8
P	Long Bolt		4
S	Nylon Bushing		4
T	Allen Wrench		1

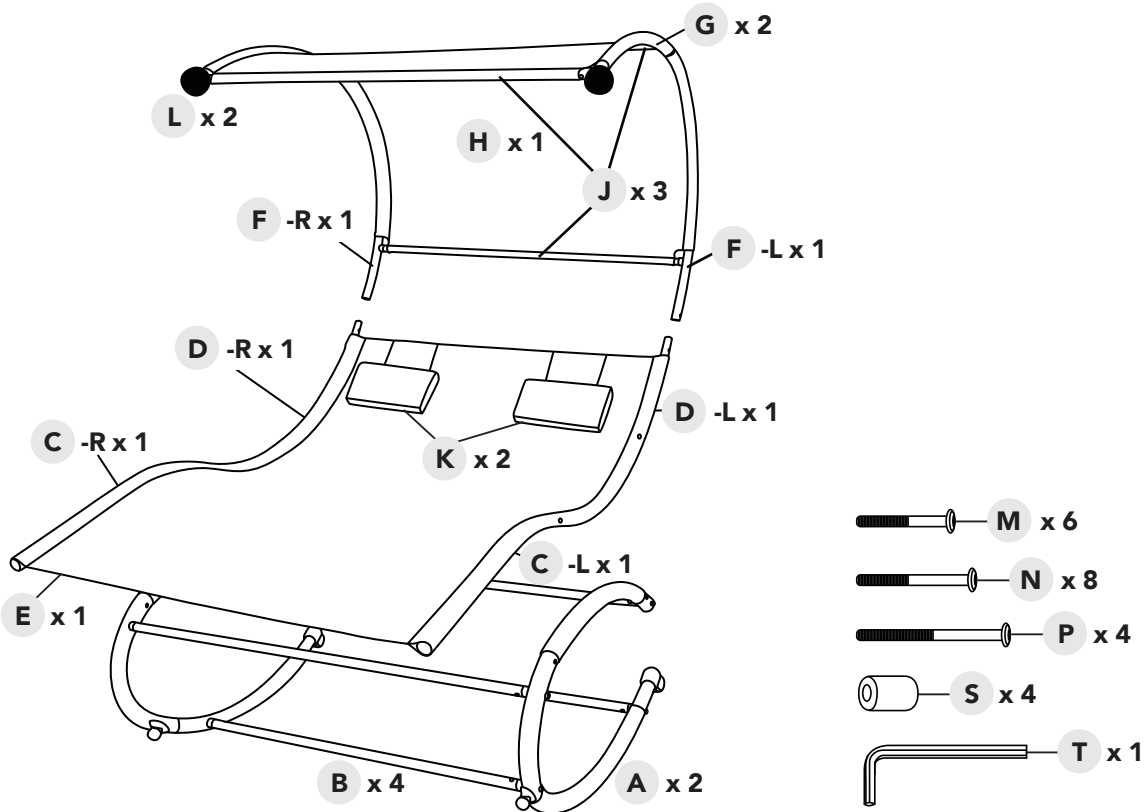

* Items included in Hardware Pack, NUP4253
 R: Right, L: Left

INSTALLATION AND ASSEMBLY

ASSEMBLY

STEP 1:

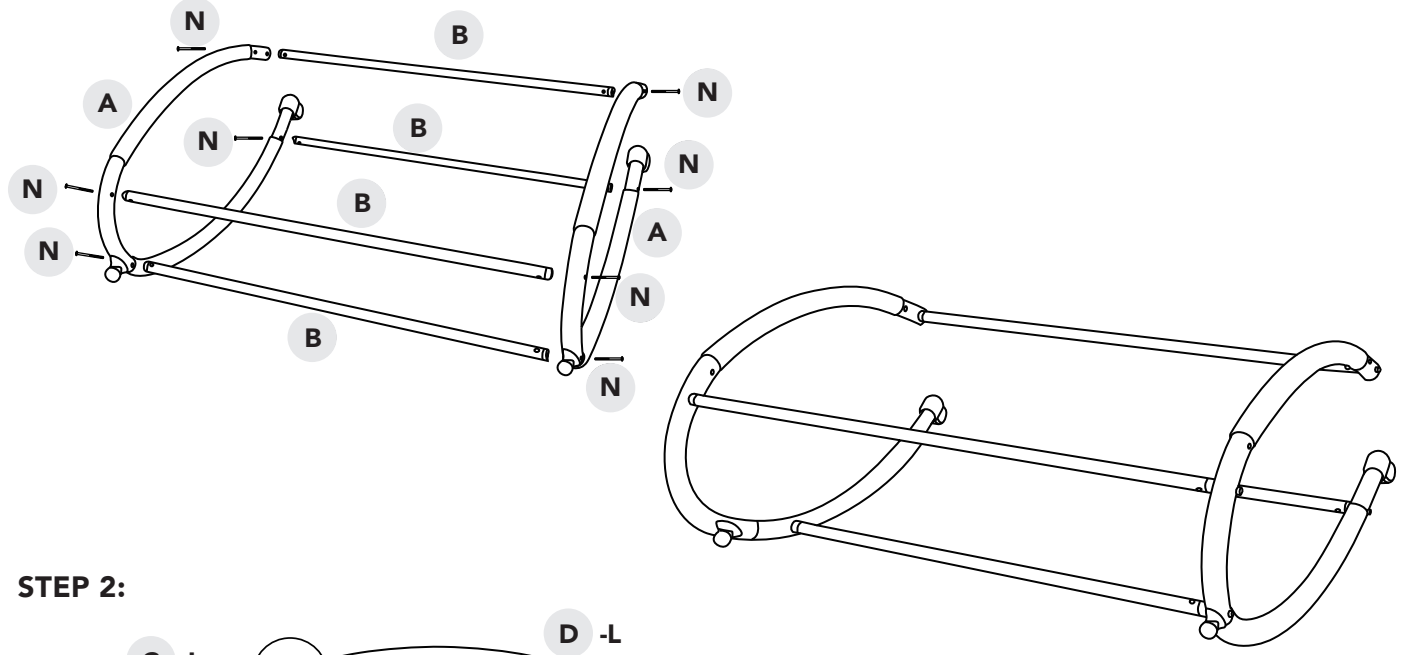

STEP 2:

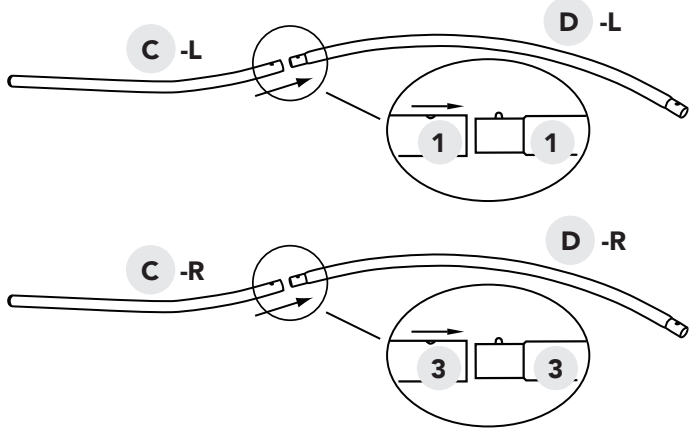

STEP 3:

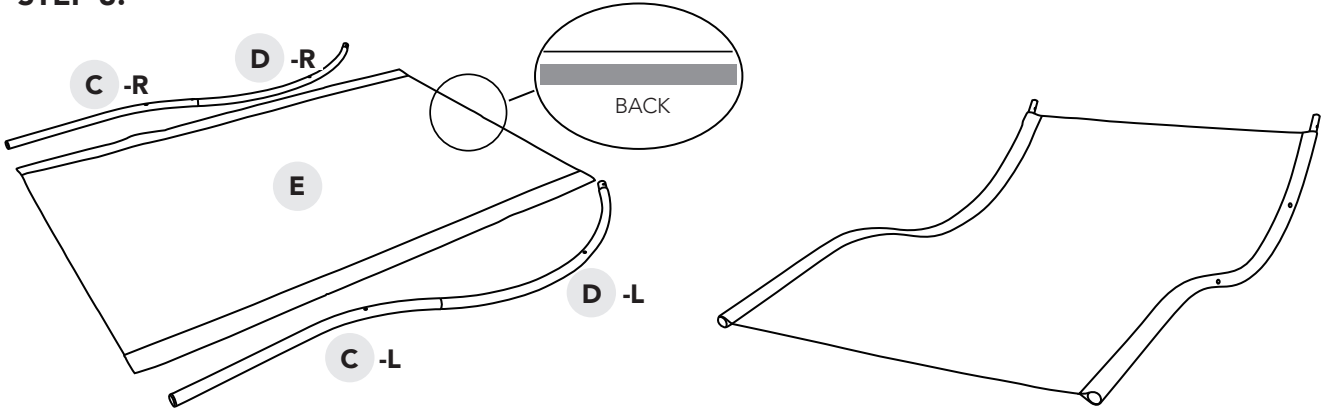

INSTALLATION AND ASSEMBLY

ASSEMBLY

STEP 4:

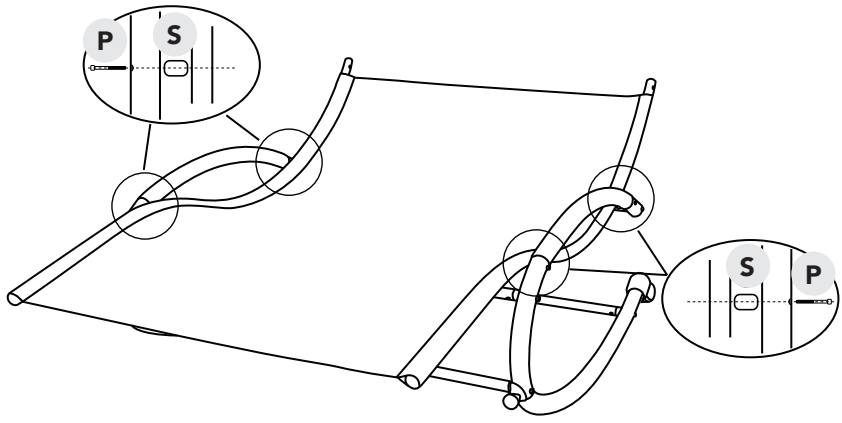

STEP 5:

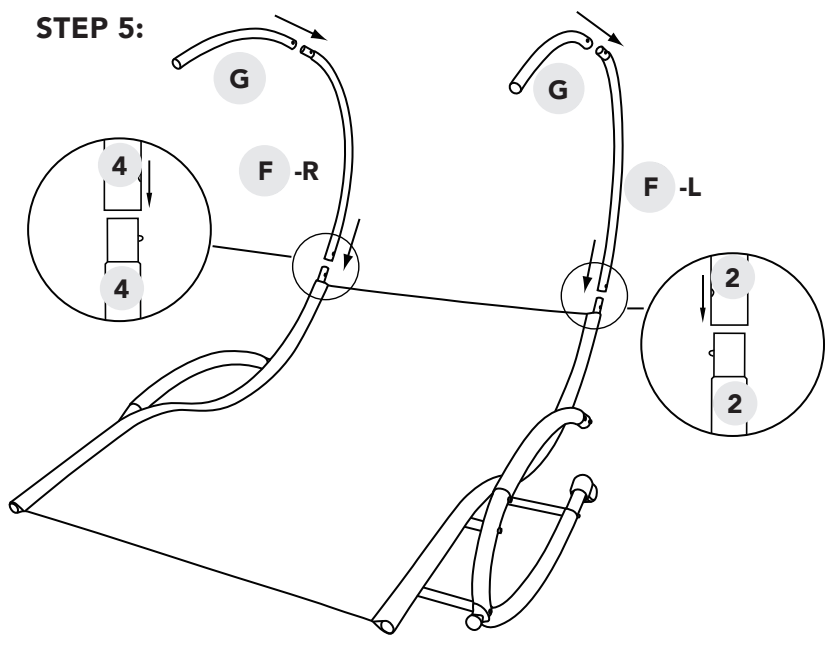

STEP 6:

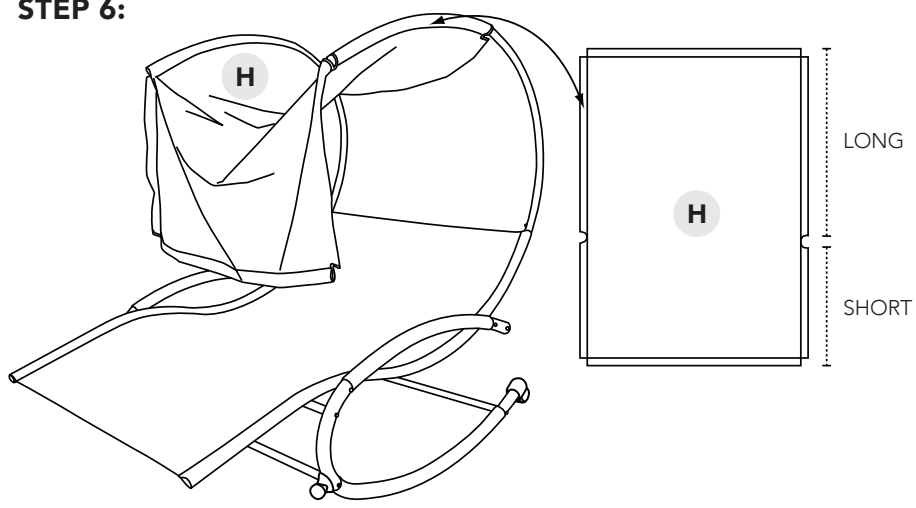

INSTALLATION AND ASSEMBLY

ASSEMBLY

STEP 7:

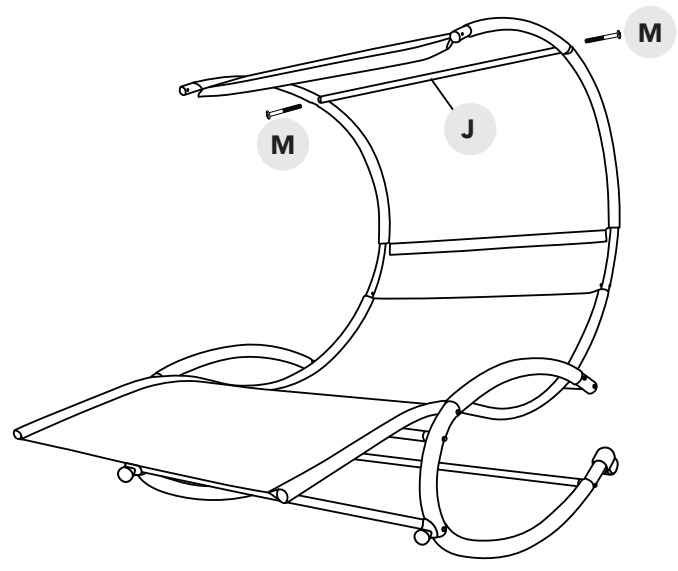

STEP 8:

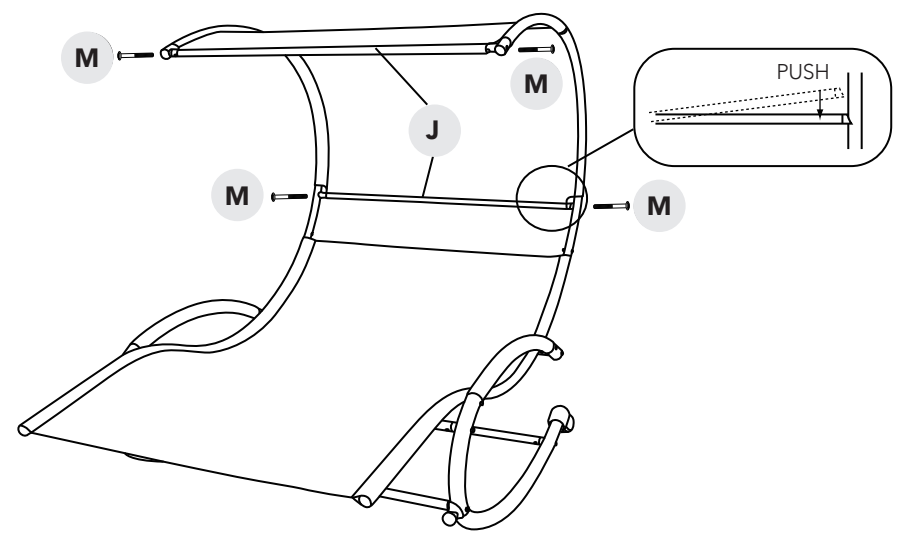

INSTALLATION AND ASSEMBLY

ASSEMBLY

STEP 9:

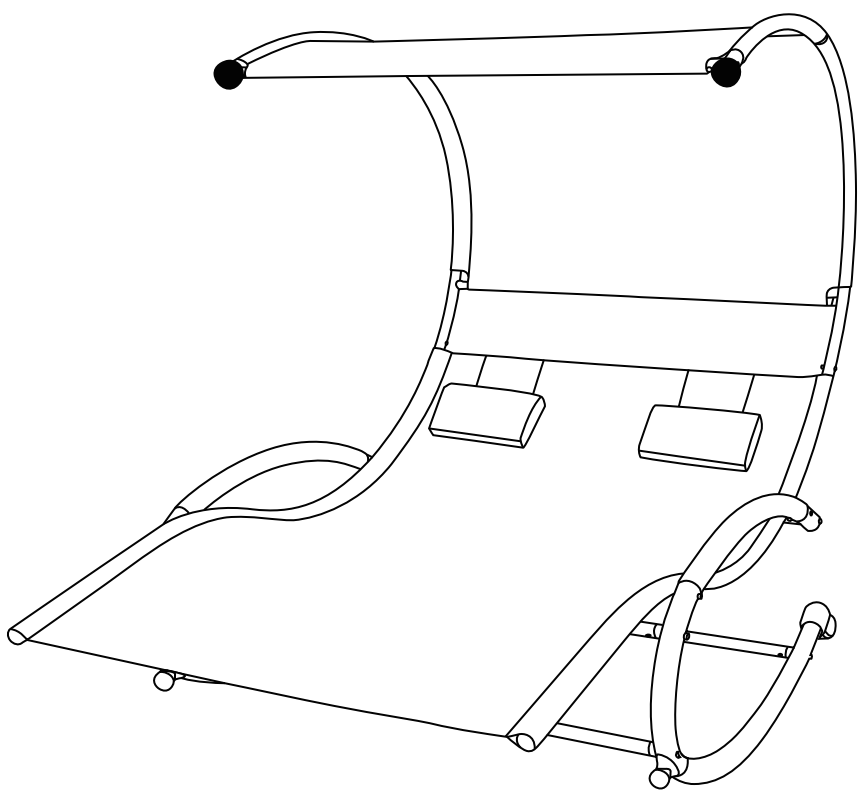
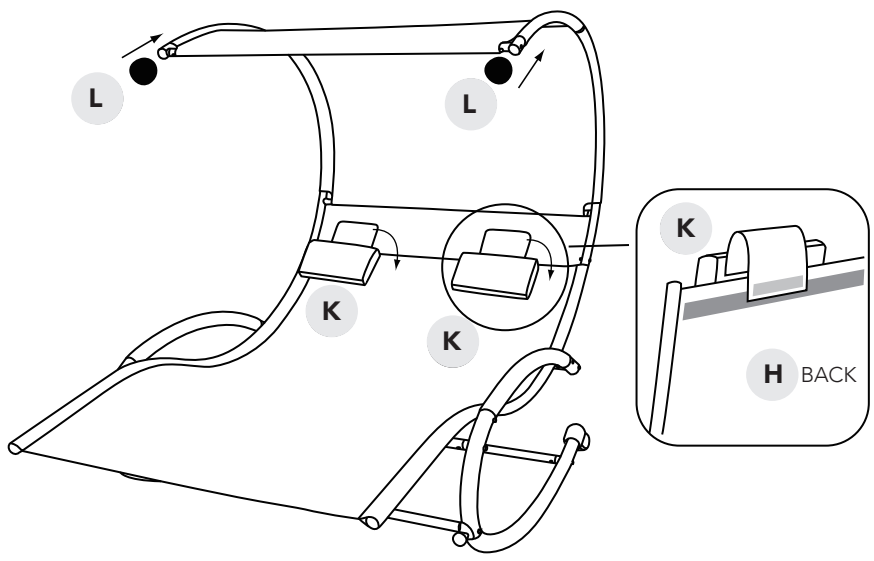

PRODUCT WARRANTY

1-YEAR LIMITED WARRANTY

This product is warranted to the original purchaser to be free from defects in material or workmanship for a period of one (1) year from the date of the original retail purchase.

This warranty does not cover defects or damage due to improper installation, alteration, accident, or any other event beyond the control of the manufacturer. Defects or damage resulting from misuse, abuse, or negligence will void this warranty. This warranty does not cover scratching or damage that may result from normal usage.

This product is not intended for institutional or commercial use; the manufacturer does not assume any liability for such use. Institutional or commercial use will void this warranty.

This warranty is nontransferable and is expressly limited to the repair or replacement of the defective product. During the warranty period, the manufacturer shall repair or replace defective parts at no cost to the purchaser. Shipping charges and insurance are not covered and are the responsibility of the purchaser. Labor charges and related expenses for removal, installation, or replacement of the product or components are not covered under this warranty.

The manufacturer reserves the right to make substitutions to warranty claims if parts are unavailable or obsolete.

The manufacturer shall not be liable for loss of use of the product or other consequential or incidental costs, expenses, or damages incurred by the consumer for any other use. The user assumes all risk of injury resulting from the use of this product.

This warranty is expressly in lieu of all other warranties, expressed or implied, including warranties of merchantability or fitness for use to the extent permitted by federal or state law. Neither the manufacturer nor any of its representatives assume any other liability in connection with this product.

All warranty claims must be made through the retailer where the product was originally purchased. A purchase receipt or other proof of date of purchase will be required to process all warranty claims. The model number and part numbers found within the assembly instructions will be required when submitting any part requests or warranty claims.

**For further warranty information or inquiries, please call 1-800-759-0977
or email warranty@splashnetxpress.com**



Blue Wave Products, Inc.
1745 Wallace Avenue, Suite B
Saint Charles, IL 60174