

# Owner's Manual

## 10-Port USB Charger with Built-In Storage

Model: U280-010-ST

### Product Features

- Charge up to 10 tablets, smartphones or other mobile devices
- Unit doubles as a USB charger and storage device, providing space to neatly organize your devices as they charge
- Removable brackets customize the unit's storage space according to the number and size of devices being charged
- Features BC1.2 rapid-charging technology that simultaneously provides up to 5V, 2A of power per port, with each port capable of providing up to 5V, 2.4A
- Over-current protection prevents devices from pulling more power than the charger is capable of supporting
- Over-charging protection stops charging when a device battery is full

### PROTECT YOUR INVESTMENT!

Register your product for quicker service  
and ultimate peace of mind.

You could also win an  
**ISOBAR6ULTRA** surge protector—  
a \$100 value!



[www.tripplite.com/warranty](http://www.tripplite.com/warranty)



Manufacturing  
Excellence.

1111 W. 35th Street, Chicago, IL 60609 USA • [www.tripplite.com/support](http://www.tripplite.com/support)

Copyright © 2015 Tripp Lite. All rights reserved.

## Package Contents

- U280-010-ST
- External Power Supply with 5-15P Plug (Input: 100V-240V, 50/60 Hz; 2.0A Max Output: 12V, 8A)
- Removable Storage Brackets (x12)
- Owner's Manual

## Optional Accessories

- M100-Series USB to Lightning™ Cables
- M110-Series USB to Apple® 30-Pin Cables
- P013-Series C5 to 5-15P Power Cords
- P058-006 C5 to SCHUKO Power Cord
- P060-006 C5 to BS-1363 UK Power Cord
- UR030-Series USB 2.0 5-Pin Mini-B Cables
- UR050-XXX-24G-Series\* 24 AWG USB 2.0 Micro-B Cable
- UR05C-Series 20 AWG USB Micro-B Charge-Only Cables
- U326-Series USB 3.0 Micro-B Cables

\*XXX represents cable length, with cable models in 1-ft. (001), 3-ft. (003) and 6-ft. (006) lengths.

## Front Panel

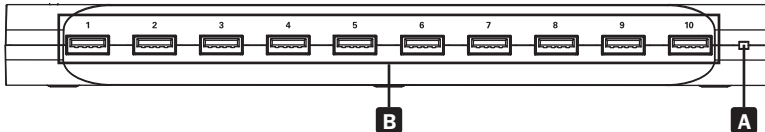

- A Power LED** – Illuminates blue to indicate that the unit is connected to a power source using the external power supply and receiving power
- B USB Charging Ports** – Each port provides a maximum of 5V, 2.4A of power. Up to 5V, 2A of power can be simultaneously provided to each port.

## USB Charging

To charge your USB devices, simply connect the included external power supply between the U280-010-ST and a power source, then plug your devices into the available ports. Each port provides a maximum of 5V, 2.4A of power. Up to 5V, 2A of power can be simultaneously provided to each port.

**Note:** In the event that more power is being pulled than the U280-010-ST can provide, the unit's over-current protection will cause the USB ports to cycle on and off, preventing any of the connected devices from being charged. If this occurs, reduce the load by removing devices until the total load comes within the supported range.

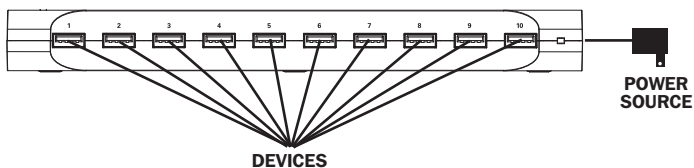

## Removable Storage Brackets

Customize the unit's storage space according to the number and size of devices being charged. To install, simply insert a storage bracket into the desired slots.

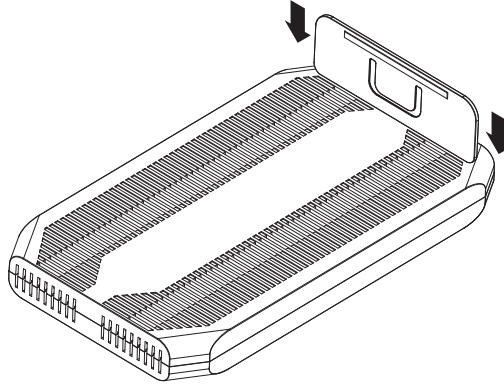

## Specifications

Item	Description
Ports	(x10) USB A Female
External Power Supply	Input: 100-240V, 50/60 Hz; 2.0A Max Output: 12V, 8A
USB Output	Up to 5V, 2A per port simultaneously, with each port capable of providing up to 5V, 2.4A
Operating Temperature	41° to 95°F (5° to 35°C)
Storage Temperature	-4 °to 122°F (-20° to 50°C)
Relative Humidity	20% to 80%
Dimensions [H x W x D]	1 x 9.4 x 5.3 in. (25 x 238 x 134 mm)
Weight	0.65 lb. (0.3 kg)
Regulatory Approvals	CE, FCC, RoHS, REACH, WEEE

# Warranty and Product Registration

## 1-Year Limited Warranty

TRIPP LITE warrants its products to be free from defects in materials and workmanship for a period of one (1) year from the date of initial purchase. TRIPP LITE's obligation under this warranty is limited to repairing or replacing (at its sole option) any such defective products. To obtain service under this warranty, you must obtain a Returned Material Authorization (RMA) number from TRIPP LITE or an authorized TRIPP LITE service center. Products must be returned to TRIPP LITE or an authorized TRIPP LITE service center with transportation charges prepaid and must be accompanied by a brief description of the problem encountered and proof of date and place of purchase. This warranty does not apply to equipment, which has been damaged by accident, negligence or misapplication or has been altered or modified in any way.

EXCEPT AS PROVIDED HEREIN, TRIPP LITE MAKES NO WARRANTIES, EXPRESS OR IMPLIED, INCLUDING WARRANTIES OF MERCHANTABILITY AND FITNESS FOR A PARTICULAR PURPOSE.

Some states do not permit limitation or exclusion of implied warranties; therefore, the aforesaid limitation(s) or exclusion(s) may not apply to the purchaser.

EXCEPT AS PROVIDED ABOVE, IN NO EVENT WILL TRIPP LITE BE LIABLE FOR DIRECT, INDIRECT, SPECIAL, INCIDENTAL OR CONSEQUENTIAL DAMAGES ARISING OUT OF THE USE OF THIS

PRODUCT, EVEN IF ADVISED OF THE POSSIBILITY OF SUCH DAMAGE. Specifically, TRIPP LITE is not liable for any costs, such as lost profits or revenue, loss of equipment, loss of use of equipment, loss of software, loss of data, costs of substitutes, claims by third parties, or otherwise.

Use of this equipment in life support applications where failure of this equipment can reasonably be expected to cause the failure of the life support equipment or to significantly affect its safety or effectiveness is not recommended. Do not use this equipment in the presence of a flammable anesthetic mixture with air, oxygen or nitrous oxide.

## PRODUCT REGISTRATION

Visit [www.tripplite.com/warranty](http://www.tripplite.com/warranty) today to register your new Tripp Lite product. You'll be automatically entered into a drawing for a chance to win a FREE Tripp Lite product!\*

\* No purchase necessary. Void where prohibited. Some restrictions apply. See website for details.

## WEEE Compliance Information for Tripp Lite Customers and Recyclers (European Union)

Under the Waste Electrical and Electronic Equipment (WEEE) Directive and implementing regulations, when customers buy new electrical and electronic equipment from Tripp Lite they are entitled to:



- Send old equipment for recycling on a one-for-one, like-for-like basis (this varies depending on the country)
- Send the new equipment back for recycling when this ultimately becomes waste

Tripp Lite has a policy of continuous improvement. Specifications are subject to change without notice.



1111 W. 35th Street, Chicago, IL 60609 USA • [www.tripplite.com/support](http://www.tripplite.com/support)

15-08-076 93-34B4\_RevA