

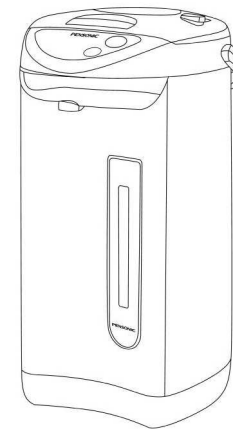

INSTRUCTION MANUAL

HOT WATER DISPENSER WITH DUAL-PUMP SYSTEM



Models:

SP-3201 (3.2 Liters)

SP-4201 (4.2 Liters)

Thank you for purchasing this appliance. Read all instructions carefully before use.

The important information, herein, is intended to prevent possible injuries and damage to the appliance. Please follow accordingly.

General Safety Precautions

- Always unplug appliance from the main electrical supply outlet before cleaning or when not in use.
- Always attach the power cord to the appliance BEFORE you plug it to the main electrical supply.
- To disconnect appliance, grasp the plug to remove, do not pull on the cord.
- Close supervision is necessary when operating appliance near children. Ensure the electrical cord does not hang over the work surface.
- Do not operate appliances with a damaged cord or plug. Any repairs should be done by an experienced technician or by an authorized service center.
- Always place appliance on a flat steady surface.
- When moving the appliance, be cautious and avoid touching hot surfaces.
- Do not immerse appliance or electrical parts in water or any other liquids.
- Use of accessories or equipment not supplied by the manufacturer may cause damage or malfunctioning of your appliance or result in injuries.
- Not suitable for outdoor usage or in damp areas. This appliance is for domestic use only.
- Do not dispense when boiling.
- Do not touch hot surfaces, use handles or knobs.
- Never block the stem vent opening.

The unit may not function properly if used in high elevation or in very cold or hot conditions. In such conditions, unit may keep boiling or not reach boiling point.

Proper Disposal



Products bearing the crossed out bin symbol are not to be disposed with your general household waste. For the correct collection and treatment of these products, take them to the collection points designated by your local authority. Alternatively contact the retailer who sold you the product.

Parts Introduction

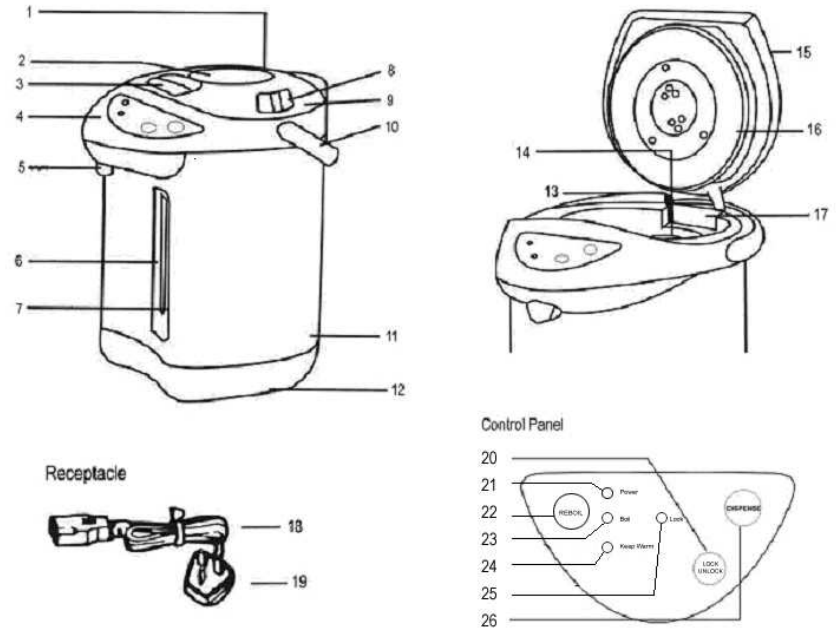

- | | |
|----------------------|-------------------------------|
| 1. Steam Vent | 14. Full Mark |
| 2. Manual Pump | 15. Detachable Upper Lid |
| 3. Lid Lock | 16. Gasket |
| 4. Control Panel | 17. Water Tank |
| 5. Spout | 18. Power Cord |
| 6. Water Level Gauge | 19. Plug |
| 7. Empty Mark | 20. Lock/Unlock Button |
| 8. Pump Lock | 21. Power indicator light |
| 9. Upper Lid | 22. Reboil Button |
| 10. Handle | 23. Boil Indicator Light |
| 11. Power Receptacle | 24. Keep Warm Indicator Light |
| 12. Rotating Base | 25. Lock Indicator Light |
| 13. Upper Lid Hinge | 26. Dispense Button |

Technical Specifications

Model	SP-3201	SP-4201
Voltage	120V~	120V~
Power	700W	700W
Capacity	3.2L	4.2L

Specifications are subject to change without prior notice with the development of technology.

Before Using

1. Please read these instructions carefully before using and keep them for future reference.
2. Check and confirm the local main voltage is the same as stated on the appliance.
3. Handle power cord carefully. Do not bend or pull on cord. Unplug from wall socket when not in use.
4. Always use the dispenser in a vertical upright position.
5. Allow dispenser to cool before cleaning.
6. The unit may be deformed or damaged when exposed to heat or used in unstable surroundings (excess water or humidity.).
7. Boiling without any water in the pot would damage the unit.
8. Avoid touching the outer body during operation. Always allow unit to cool before handling.
9. Do not immerse power cord or unit in any water or any liquid.
10. Close supervision is necessary when appliance is used by or near children. Never leave appliance unattended.
11. Do not operate any appliance with a damaged cord or plug or malfunctions or has been damaged in any manner.
12. Do not attempt to repair the appliance, contact Sunpentown.
13. Never use attachments not recommended by the manufacturer.
14. The appliance is not intended for outdoor use or in damp areas. Household use only.
15. Power cord should not be tangled, left on hot surfaces or allowed to hang over table edges.
16. Appliance should be given ample air circulation on all sides.
17. An insulated hot pad is recommended on surfaces where heat may cause problems.
18. Do not use appliance for other than its intended usage.
19. Be cautious of hot steam when opening the top lid.

20. Point steam away from power point switch and furniture.
21. Keep flammable materials away from appliance.
22. Handle power cord carefully as cord may malfunction if dropped.
23. It is normal for smoke and smell to be emitted during first use, it will stop after a short period of usage.
24. Be extra careful when moving the appliance filled with hot water.
25. Do not fill above the "Full" water guide mark.
26. Do not cover or block steam vent with cloth or any material.
27. Always ensure the lid is closed properly.
28. Make full use of handle when moving the appliance.

How To Use

● HAZARDS

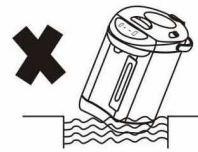

To protect against electric shock, do not immerse base, cord or plug in water or other liquid.

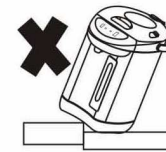

Do not place on unstable surfaces.



Only fill with pure water. Do not put milk, tea, ice or any other substance into dispenser.



Do not fill above the maximum level mark inside the tank or lower than the minimum level to avoid damage to the product.

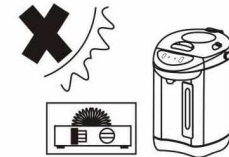

Do not place on or near a hot gas or electric burner, or a heated oven.

● Removing and attaching top lid

1. Pull on lid lock and open lid to about 45-degree angle and remove lid from securing hinge.
2. To attach, insert the shaft of the lid into the hinge holder. Close and press on lid unit it clicks.
 - Never remove lid while the appliance is operating.
 - Be cautious of steam when opening lid.

● **Using the dispenser for the first time**

- Wash and rinse inner tank with water.
 - Fill water up to full line.
 - Boil once and discard water by pumping it out.
1. **Open top lid and add water**
- Pull up on the lid lock and open top lid.
 - Fill with cold water from another container, such as a kettle or pitcher. Do not fill directly under faucet.
 - To prevent overflow, do not fill above the maximum mark.
 - Be careful not to splash water onto the control panel.
2. **Close the top lid**
- Carefully close lid by pressing down until a click is heard
 - Do not close lid forcefully, hot water may gush out and scald.
3. **Boiling the water**
- Unit begins to function (boil) once power is connected.
 - First attach body plug to receptacle then plug into to wall outlet.
 - Never connect power when unit is empty.
 - When rotating the body, be cautious of the power cord.
4. **Reading the control panel**
- “Boil” light is on during the boiling cycle
 - Will switch to “Keep Warm” automatically when water is boiled
 - Do not open the top lid.
 - Do not touch the steam vent.
 - Do not place cloth or other items covering the steam vent.
 - Do not dispense water while water is boiling.
5. **Dispensing water – electric pump**
- Press the “Dispense” button to dispense hot water
 - Hot water may not dispense smoothly immediately after boiling, this is due to air bubbles trapped inside.
 - Never press the “Dispense” button if dispenser is empty.
 - Electric dispense will not work if unit is unplugged.
6. **Dispensing water – manual pump;**
- Switch manual pump lock to “Unlock”
 - Press down on the manual pump
- NOTE:**
- Add water before water level reaches the “Refill” line.
7. **Reboil function**
- Make sure water level is above the “Refill” mark before reboiling.
 - Re-boiling a full container takes about 3 minutes.
 - The re-boil key may not respond right after the water has boiled.
 - Once the Re-boil button is pressed, the boiling process cannot be reset until the dispenser automatically switches to Keep Warm mode.
 - Do not press the Re-boil button repeatedly as the continuous boiling process may cause unit to malfunction.

Cleaning and Maintenance

Disconnect power and allow appliance to cool before cleaning.

- Disconnect power from wall outlet and remove cord from receptacle.
- Detach upper lid and pour out remaining water. Be cautious if water is hot.
- Do not wash under running water. Do not place in a dishwasher or dryer.
- Do not wet the control panel and receptacle.
- Do not leave water in pot unused for long period of time.
- Do not turn unit upside-down to dry.
- Do not immerse any part of the dispenser in water or any liquid.
- Do not use bleach, alcohol or other harsh chemicals
- Do not scrub with metal pads or sharp objects.
- Upper lid must be detached when pouring out water.
- Do not handle plug when hands are wet or damp.

Minerals in tap water may cause white residue to attach to the surface of the inner tank. They sometimes change the color of the inner tank (reddish or black). Clean the interior frequently to avoid this problem.

Lid and body

- Wipe clean with damp cloth.

Inner pot and inner lid

Use soft sponge to clean and rinse with water. The amount of build-up and stain depends on the quality of water and times of boiling. The inner pot should be cleaned once a month. If extremely dirty, use Citric Acid, lemon or lime juice:

- Add approximately 1 oz. of the preferred solution.
- Add water to the full line, close lid and connect power.
- Allow solution to boil and soak for 30~60 minutes.
- Dispense a few cups of solution to clean the piping.
- Disconnect power and allow unit to cool.
- Remove lid and pour out solution, rinse clean.
- If lemon was used, to remove the smell of lemon, fill with clean water, boil and dispose.
- DO NOT use: dish soap, scrubbing powder or brush, benzene, thinner or any harsh chemicals.

When not in use for an extended period of time, clean and let dry completely before storage. Store in original packaging or plastic bag and keep in a cool, dry place.

Important Guidelines

A short power cord is provided to minimize the hazards involved with tripping over longer cords.

Longer extension cords can be purchased and used with this appliance, however one should exercise care and caution. The extension cord should have 1) a minimum acceptable marked electrical rating similar to that of the appliance, 2) should be a grounded three-prong plug and 3) should be arranged so that it will not drape over counter top or table top where it can be easily pulled or tripped.

WARNING: THIS APPLIANCE MUST BE GROUNDED

Trouble Shooting

SYMPTOM	POSSIBLE CAUSE
Water does not boil when plugged in. (Power LED on)	Dirty inner pot. Added water is already hot. Water level is below refill line.
Unit will not switch to Keep Warm	Unit may not function properly if used in high elevation or in very cold or hot conditions. In such conditions, unit may keep boiling or not reach boiling point.
Unit will not switch to Boil	Water level is too low. Dirty inner pot
Auto pump does not work or not working efficiently	Unit not plugged in. Immediately after boiling, bubbles may form which makes it difficult to dispense. Open the lid to release steam. The interior is dirty and needs cleaning
Water is flowing out from unit	Water is filled above the FULL line.
White substance floating in water	These are mineral deposits. (Not erosion of inner pot.) Clean the unit according to the instructions under Maintenance
Boiling sound is excessively loud	Interior is dirty and needs cleaning.
Hot water has unpleasant odor or taste	Resin used in manufacturing may give off a mild odor. This will disappear with use. Due to chlorine in water – reboil the water



Your Guarantee

If this product is found to be faulty as a result of faulty materials or Workmanship within one year from date of purchase, it will be repaired free of charge.

This guarantee is subject to the following terms:

- Sunpentown must be notified of the fault.
- Proof of purchase must be presented to Sunpentown's nominated representative.
- The warranty will be void if the product is modified, misused or repaired by an unauthorized person.
- The warranty after repair will not be extended beyond the original one-year period.
- All replacement parts will be new or reconditioned.
- Parts, which are replaced, become the property of Sunpentown.
- The warranty applies for the use of the product in the USA only.

What is NOT COVERED:

- Warranty does not include freight charges.
- Incidental or consequential damage caused by possible defects with this product.
- Damage to product caused by improper power supply voltage, accident, fire, floods or acts of nature.
- Failure of product resulting from unauthorized modifications to the product.
- Improper installation or failure to perform the necessary maintenance.

This GUARANTEE is in addition to your Statutory Rights

Sunpentown Int'l Inc.

14625 Clark Ave, City of Industry, CA 91745

Tel: 1-800-330-0388

service@sunpentown.com · www.spt-usa.com