



WWW.SMITTYBILT.COM

## Installation Instructions

XRC 3.0 3,000lb Winch  
Part # 97203

Parts Included	Qty
Winch with Wire Rope	1
Winch Plate	1
Clevis Hook	1

Parts Included	Qty
Remote Control	1
Handle Bar Control	1
Hardware Pack	1

**NOTE:** Read, study and follow all instructions before operating and installing this product. Failure to heed these instructions may result in personal injury and/or property damage.

This winch can develop tremendous pulling forces and if used unsafely or improperly could result in property damage, serious injury or death. Throughout this manual you will notice headings such as **Caution, Warning and Danger**. Pay particular attention to these headings as they are written for your safety.. Ultimately, safe operation of this product rests with you, the operator.

### WINCH ASSEMBLY AND MOUNTING

1. Your winch is designed with a bolt pattern that is standard in this class of winches. Many winch mounting kits are available that utilize this bolt pattern for the most popular ATV's and mounting channels.
2. Regardless of the mounting kit you use, ensure that your winch is mounted on a flat surface so that the three major sections (motor, drum and gear housing) are properly aligned. Proper alignment of the winch will allow even distribution of the full rated load.
3. Utilize the M8x30 mounting bolts, washers and nuts included.
4. Connect the battery (4' 1") and motor (5' 9") leads. Connect the red positive (+) to the in-facing terminal marked (+) on the motor and the black negative (-) to the out-facing terminal marked (-) on the motor. Then connect the red positive (+) lead from the power switch to the positive (+) terminal of the vehicles 12 volt battery. Connect the black negative (-) lead from the power switch to the negative (-) terminal of the battery. (**Caution:** Batteries contain gases which are flammable and explosive. Wear eye protection during installation and remove all jewelry. Do not lean over battery when making connections.

For Technical Support/Warranty Information please call 310-762-9944

Smittybilt, 400 West Artesia Blvd, Compton, CA 90220



WWW.SMITYBILT.COM

## Installation Instructions

XRC 3.0 3,000lb Winch

Part # 97203

5. Assemble the clevis hook to the cable. Pull and turn the clutch knob to the "Off" position (Free spooling), pull out some cable from the drum. Take the pin from the clevis hook, connect the clevis hook to the cable and mount the pin back to the clevis hook.
6. Always use the hand saver when free-spooling and re-spooling the wire rope. Using the hand saver keeps your hands and fingers away from the rotating drum.
7. Check for proper drum rotation. Pull and turn the clutch knob to the "off" position (free-spooling). Pull out some cable from the drum, then turn the clutch knob to the "in" position to engage the gears. Press the cable out button on the power switch. If the drum is turning and releasing more cable then your connections are accurate. If the drum is turning and collecting more cable then reverse the leads on the motor. Repeat and check rotation.

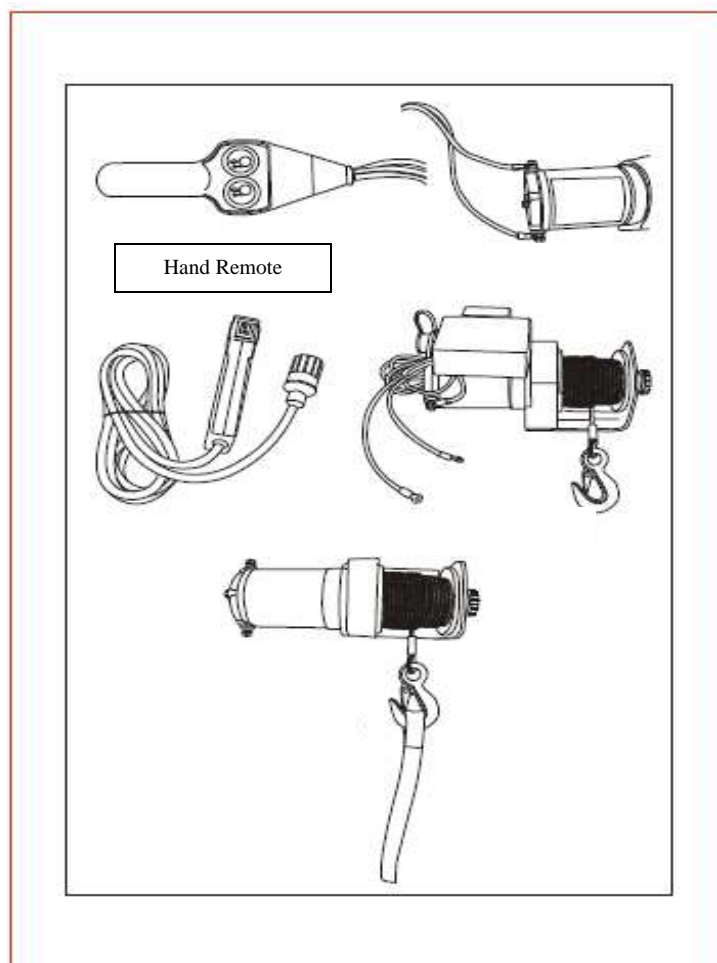

For Technical Support/Warranty Information please call 310-762-9944

Smittybilt, 400 West Artesia Blvd, Compton, CA 90220



WWW.SMITYBILT.COM

## Installation Instructions

XRC 3.0 3,000lb Winch  
Part # 97203

### Handle Bar Switch Assembly

When installing your ATV winch system, read and follow all mounting and safety instructions. Always use caution when working with electricity and remember to verify that no exposed electrical connections exist before energizing your winch circuit.

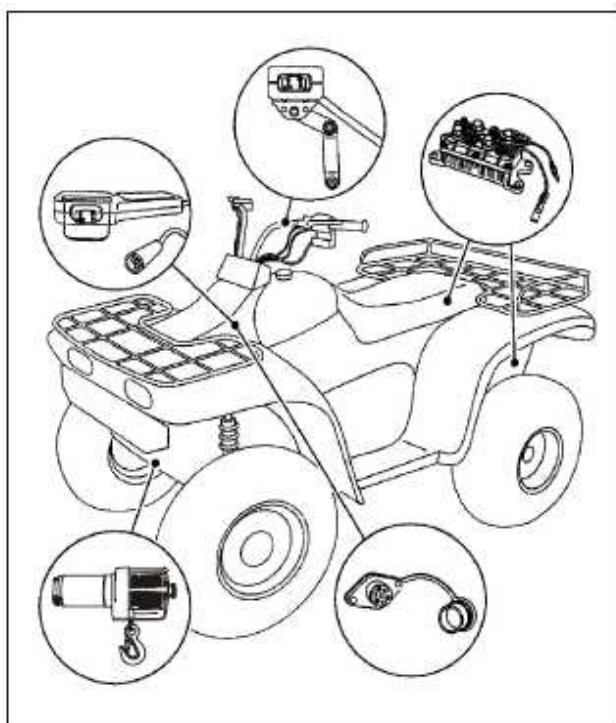

To install the complete kit, you will need to mount the winch, contactor handlebar mounted mini-rocker switch and remote socket. Mounting locations may vary depending on the make and model of the ATV. Read and understand the following instructions to choose the appropriate mounting locations.

It is recommended that the switch be installed on left handlebar. A piece of electrical tape around the handlebar will help prevent rotation of mount on the handle bar. Do not tighten over and hoses or cables. Once the handle bar switch is mounted, route the two bullet terminal wires back to where the contactor will be mounted. Splice the end of the red 20ga wire to key controlled electrical wire of the ATV. Using a test light, locate a suitable wire from the ATV key switch. The wire should only have power when the key is in the "ON" position.

**For Technical Support/Warranty Information please call 310-762-9944**

**Smittybilt, 400 West Artesia Blvd, Compton, CA 90220**



WWW.SMITYBILT.COM

**Installation Instructions**  
XRC 3.0 3,000lb Winch  
Part # 97203

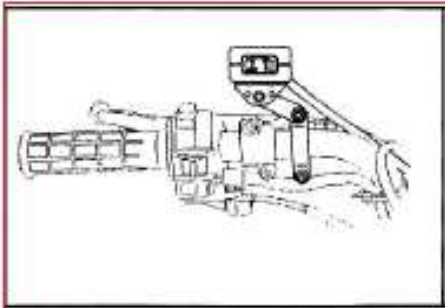

Handlebar mount-Exact location may vary depending on ATV make and model.

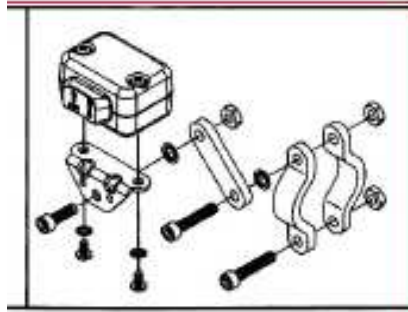

Mini-rocker switch assembly

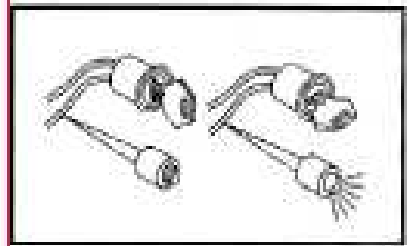

Use a test light to locate a suitable wire

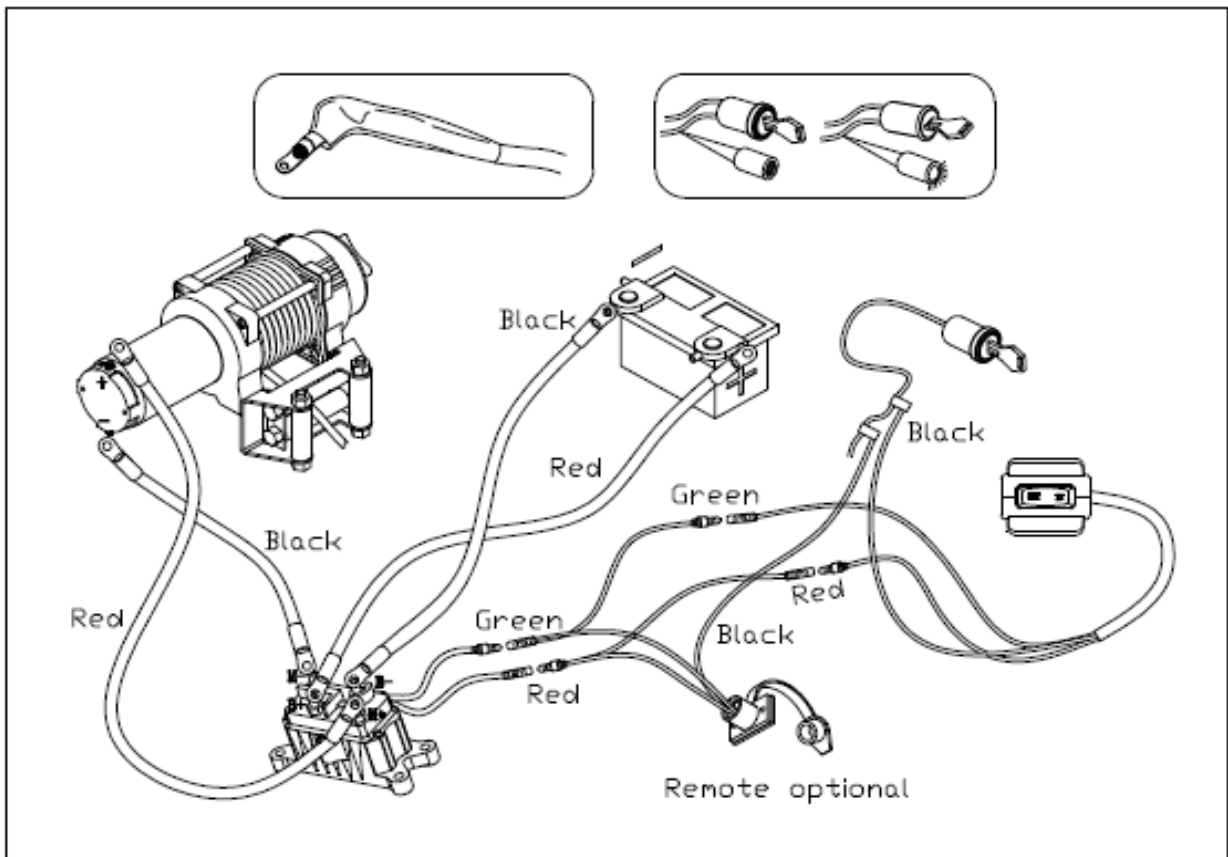

For Technical Support/Warranty Information please call 310-762-9944

Smittybilt, 400 West Artesia Blvd, Compton, CA 90220



WWW.SMITTYBILT.COM

**Installation Instructions**  
XRC 3.0 3,000lb Winch  
Part # 97203

---

---

**SAFETY PRECAUTIONS**

**!WARNING!**

Do not Exceed Rated Capacity.

Intermittent use only.

Do not use winch in lifting or moving persons.

A minimum of five wraps of cable around the drum barrel is necessary for pulling and holding the rated load. The cable clamp is not designed to hold the load without 5 wraps of cable around the barrel.

Keep yourself and others a safe distance to the side of the cable when under tension.

The wire rope may break before the motor stalls. For heavy loads at our near rated capacity, use a pulley/snatch block to reduce the load on the wire rope.

Never step over a cable or near a cable under load.

Don't move the vehicle to pull a load (towing) on the winch cable. This could result in cable breakage.

Disconnect the remote control and battery leads when not in use.

Do not exceed maximum pull rating. Avoid "shock loads" by using the control switch intermittently to take up the slack in the wire rope. "Shock loads" can far exceed the rate capacity for the wire rope and drum.

Do not exceed maximum line pull ratings shown in the tables.

Do not use as a hoist. Do not use for overhead lifting.

**For Technical Support/Warranty Information please call 310-762-9944**

---

**Smittybilt, 400 West Artesia Blvd, Compton, CA 90220**



WWW.SMITTYBILT.COM

**Installation Instructions**  
XRC 3.0 3,000lb Winch  
Part # 97203

---

When re-spooling the cable, ensure that the cable spools in the under-wind position with the cable entering the drum from the bottom and not the top. To re-spool correctly, and while wearing gloves, keep a slight load on the cable while pushing the remote button to draw in the cable. Walk toward the winch not allowing the cable to slide through your hands. Do not let your hands get within 12" of the winch while re-spooling. Turn off the winch and repeat the procedure until a few feet of cable is left. Disconnect the remote control and finish spooling by hand by rotating the drum by hand with the clutch disengaged. Keep hands clear of the fairlead and drum while the winch is under power.

**Failure to heed these warnings may result in personal injury or property damage.**

**CAUTION**

Use gloves to protect hands when handling the cable. Never let the cable slide through your hands.

Apply blocks to the wheels of the vehicle when on an incline.

No modifications, alterations, or deviation to the winch are authorized by the manufacturer and should not be made.

Duration of winching pulls should be kept as short as possible. If the motor becomes uncomfortably hot to the touch, stop winching immediately and let it cool down for a few minutes.

Do not pull for more than one minute at or near the rated load.

If the motor stalls do not maintain power to the winch. Electric winches are designed and made for intermittent use and should not be used in constant duty applications.

Never release the free-spool clutch when there is a load on the winch.

Use hand saver hook when handling the hook for spooling or un-spooling the wire rope.

**For Technical Support/Warranty Information please call 310-762-9944**

---

**Smittybilt, 400 West Artesia Blvd, Compton, CA 90220**





WWW.SMITTYBILT.COM

**Installation Instructions**  
**XRC 3.0 3,000lb Winch**  
**Part # 97203**

---

---

**GENERAL TIPS FOR SAFE OPERATION**

The XRC3.0 is rated at 3,000lbs capacity when spooling the first layer on the drum. Overloads can damage the winch/motor/or wire rope. For loads over 50% we recommend the use of a pulley/snatch block to double the wire rope line. This will help in two ways, 1) reduce the number of rope layers on the drum, 2) reduce the load on the wire rope by as much as 50%. When doubling the line back to the vehicle, attach to the frame or other load bearing point.

The vehicle engine should be kept running during operation of the winch to minimize battery drain and maximize power and speed of the winch. If the winch is used for a considerable time with the engine off the battery may be drained and too weak to restart the engine.

Get to know your winch before you actually need to use it. We recommend that you set up a few test runs to familiarize yourself with rigging techniques, the sounds your winch makes under various loads, the way the cable spools on the drum, ect....

Inspect the wire rope and equipment before each use. A frayed or damaged cable should be replaced immediately. Use only manufacturer's identical replacement cable with the same specifications.

Inspect the winch installation and bolts to ensure that all bolts are tight before operation.

Never connect the cable back to itself. This will cause cable damage. Always use a snatch block, sling or chain of suitable strength as shown the illustrations.

Store the remote control inside your vehicle in a place that it wont get damaged.

Any winch that appears to be damaged in any way, is found to be worn, or operates abnormally need to be removed from service until repaired. It is recommended that the necessary repairs be made by an authorized winch repair facility.

Pull only on areas of the vehicle as specified by the vehicle manufacturer.

Only attachments and/or adapters supplied by the manufacturer should be used.

**For Technical Support/Warranty Information please call 310-762-9944**

---

**Smittybilt, 400 West Artesia Blvd, Compton, CA 90220**



WWW.SMITTYBILT.COM

**Installation Instructions**  
**XRC 3.0 3,000lb Winch**  
**Part # 97203**

**RIGGING TECHNIQUES**

**Self Recovery**

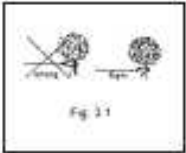

Locate a suitable anchor such as a strong tree trunk or boulder. Always use a sling as an anchor point. **Caution:** Do not attach clevis hook back onto cable as this could cause damage to the cable.

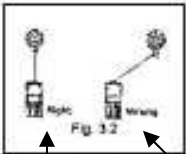

Do not winch from an acute angle as the wire rope will pole up on one side of the drum causing damage to the wire rope and winch. Short pulls from an angle can be used to straighten the vehicle.

correct      wrong

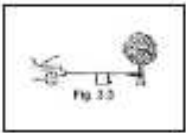

When pulling a heavy load, place a blanket or jacket over the wire rope five or six feet from the hook. In the event of a broken cable it will dampen the snap back.

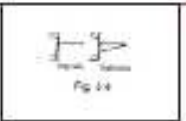

For pulls over 1,000lbs we recommend the use of a snatch block/pulley block to double the line. This reduces the load on the winch and strain on the wire by approx 50%



**WARNING:** Never use your winch for overhead hoisting or for lifting people or moving people.

**WINCHING TECHNIQUES A-Z**

- A. Take your time to asses your situation.
- B. Put gloves on to protect your hands.
- C. Disengage the clutch to allow free-spooling and also save battery power.

**For Technical Support/Warranty Information please call 310-762-9944**





WWW.SMITTYBILT.COM

**Installation Instructions**  
**XRC 3.0 3,000lb Winch**  
**Part # 97203**

- D. Attach the hand saver hook strap to the clevis hook.
- E. Pull out the wire rope to your desired anchor point using the hand saver strap.
- F. Secure the clevis hook to the anchor point sling, chain or snatch block. Do not attach the hook back onto the wire rope.
- G. Engage the clutch.
- H. Connect the remote control to the winch.
- I. Start your engine to ensure power is being replenished to the battery.
- J. Power in the wire rope guiding the wire under tension to draw up the slack in the wire. Once the wire is under tension stand well clear. Never step over the cable.
- K. Double check your anchors and make sure all connections are secure.
- L. Inspect the wire rope. Make sure there are at least 5 wraps of wire rope around the winch drum.
- M. Drape a blanket or jacket over the wire rope approximately 5 to 6 feet from the hook. Open the hood for added protection if applicable.
- N. Clear the area. Make sure all spectators are well back and that no one is directly in front or behind the vehicle or anchor point.
- O. Begin winching. Be sure that the wire rope is winding evenly and tightly around the drum. The vehicle that is being winched can be slowly driven to add assistance to the winding process. Avoid shock loads; keep the wire rope under tension.
- P. The vehicle to be winched should be placed in neutral and the emergency brake released. Only release the brake pedal when under full tension. Avoid shock loads to the winch. This can damage the winch, rope and vehicle.
- Q. The winch is meant for intermittent use. Under full load with a single ling rig do not power in for more than a minute without letting the motor cool down for a few minutes and then resume winching operation.
- R. The winching operation is complete once the vehicle is on stable ground and is able to drive under its own power.
- S. Secure the vehicle. Be sure to set the brake and place the vehicle park.
- T. Release the tension on the wire rope. The winch is not meant to hold the vehicle for long periods of time.
- U. Disconnect the wire rope from the anchor.
- V. Rewind the wire rope. Make sure that any wire already on the drum has spooled tightly and neatly. If not, draw out the wire and re-spool from the point where the rope is tight.
- W. Keep your hands clear of the winch drum and fairlead as the wire rope is being drawn in.
- X. Secure the hook and hook strap.
- Y. Disconnect the remote control and store in clean, dry and secure place.
- Z. Clean and inspect the connection and mounting hardware for next needed operation.

**For Technical Support/Warranty Information please call 310-762-9944**

**Smittybilt, 400 West Artesia Blvd, Compton, CA 90220**



WWW.SMITTYBILT.COM

**Installation Instructions**  
XRC 3.0 3,000lb Winch  
Part # 97203

---

---

**MAINTENANCE**

1. Periodically check the tightness of the mounting bolts and electrical connections. Remove all dirt or corrosion and always keep clean.
2. Do not attempt to disassemble the gear box. Repairs should be done by and authorized repair center.
3. The gear box has been lubricated using a high temperature lithium grease and is sealed at the factory. No internal lubrication is required.

**REPLACING THE WIRE CABLE**

1. If the wire cable has become worn or is beginning to show signs of strands breaking it must be replaced before being used again. To do this, remove the defective cable by free spooling it out. Remove the 5 x 5mm bolt on the drum and release the cable.
2. Insert the end of the new cable and secure with the previously removed bolt.
3. Engage the clutch and re-spool the new cable on the drum keeping tension on the cable as it spools. Ensure that the cable is re-spooling in the under wind position.

**NOTE:** Only replace the cable with the identical manufacturer's cable.

**For Technical Support/Warranty Information please call 310-762-9944**

---

**Smittybilt, 400 West Artesia Blvd, Compton, CA 90220**



WWW.SMITTYBILT.COM

**Installation Instructions**  
**XRC 3.0 3,000lb Winch**  
**Part # 97203**

**TROUBLE SHOOTING**

SYMPTOM	POSSIBLE CAUSE	SEGGESTED ACTION
Motor does not turn on	-Switch Assembly not connected properly -Loose battery cable Connections -Solenoid malfunctioning -Defective Switch Assembly -Defective motor  -Water has entered motor	-Insert Switch Assembly all the way into the connector. -Tighten nuts on all cable connections. -Tap solenoid to loosen contacts. Apply 12volts to coil terminals directly A clicking indicates proper activation. -Replace Switch Assembly -Check for voltage at armature port with Switch pressed. If voltage is present replace motor. -Allow to drain and dry. Run in short bursts without load until completely dry.
Motor runs but Cable drum does not turn	-Cam Ring (clutch) not engaged	-Move Cam Ring to the "in" position. If problem persists, a qualified technician needs to check and repair.
Motor runs slowly or without normal power	-Insufficient current or voltage	-Battery weak, recharge. Run winch with vehicle motor running. -Loose or corroded battery cable connections. Clean ,tighten, or replace
Motor overheating	-Winch running time too long	-Allow winch to cool down periodically.
Motor runs in one direction only	-Defective or stuck solenoid -Defective Switch Assembly	-Tap solenoid to loosen contacts. -Repair or replace solenoid. -Replace Switch Assembly

**For Technical Support/Warranty Information please call 310-762-9944**

**Smittybilt, 400 West Artesia Blvd, Compton, CA 90220**



WWW.SMITTYBILT.COM

**Installation Instructions**  
XRC 3.0 3,000lb Winch  
Part # 97203

NO	S.B part#	QTY	Description
1	97203-01	1	Motor
2	97203-02	1	gasket
3	97203-03	1	bearing
4	97203-04	1	bearing bushing
5	97203-05	1	brake base
6	97203-06	1	brake gear
7	97203-07	1	drum support motor side
8	97203-08	2	drum bushing
9	97203-09	2	tie rod
10	97203-10	1	bushing for water proof
11	97203-11	2	o-ring for water proof
12	97203-12	1	drum
13	97203-13	1	spring
14	97203-14	2	Split snap ring
15	97203-15	1	shaft
16	97203-16	1	gear box cover
17	97203-17	1	Gasket
18	97203-18	1	splined gear
19	97203-19	1	Gear carrier assembly state 3
20	97203-20	1	Gear carrier assembly state 2
21	97203-21	1	Gear carrier assembly state 1
22	97203-22	1	sun gear
23	97203-23	1	gasket
24	97203-24	1	Slide block for clutch
25	97203-25	1	gear ring
26	97203-26	1	gear box body
27	97203-27	1	bushing
28	97203-28	1	clutch knob
29	97203-29	1	wire rope and hook
	97203-30	1	Remote
	97203-31	1	Handle Bar Control
	97203-32	1	Winch Plate
	97203-33	1	Solenoid

For Technical Support/Warranty Information please call 310-762-9944

Smittybilt, 400 West Artesia Blvd, Compton, CA 90220



WWW.SMITYBILT.COM

**Installation Instructions**  
XRC 3.0 3,000lb Winch  
Part # 97203

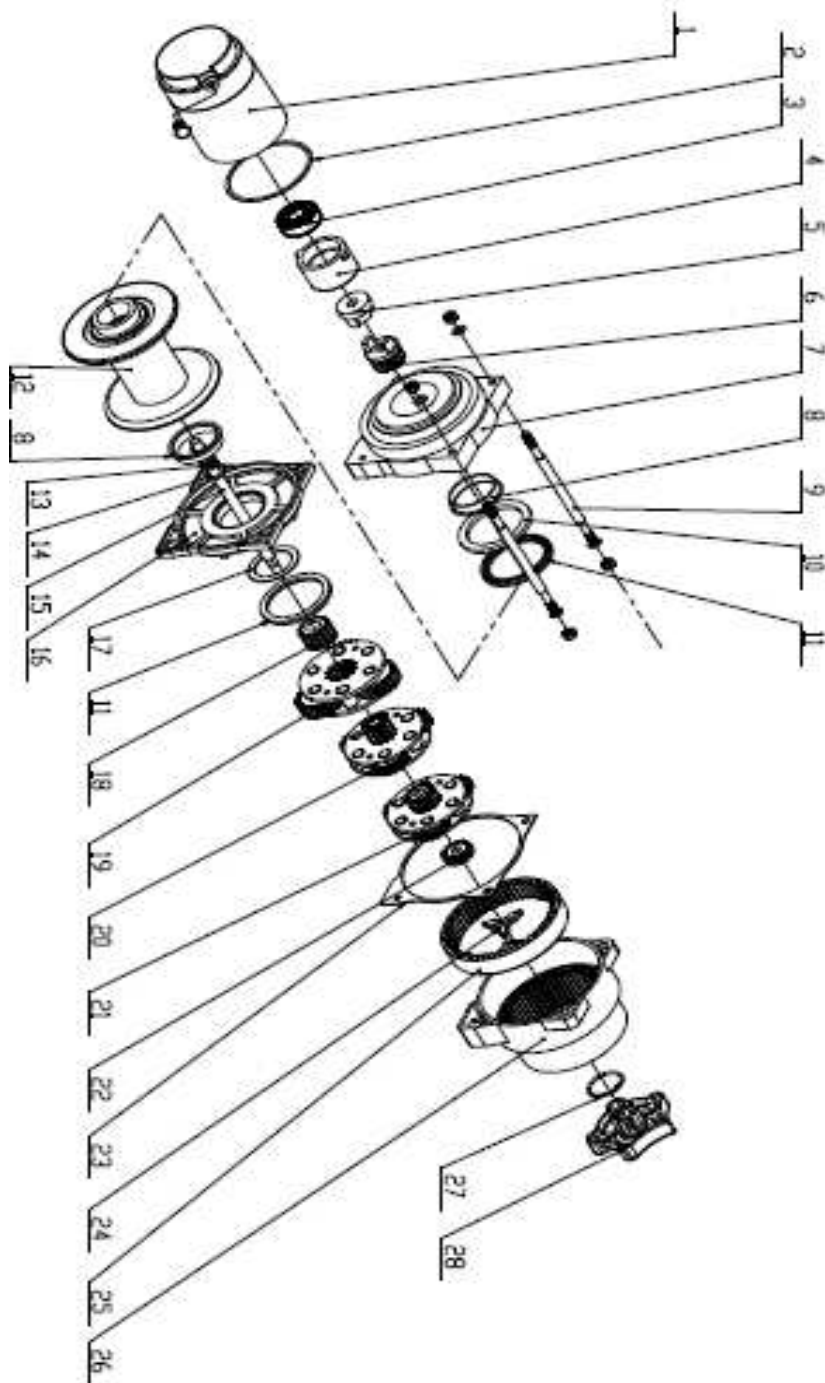

For Technical Support/Warranty Information please call 310-762-9944

Smittybilt, 400 West Artesia Blvd, Compton, CA 90220



WWW.SMITTYBILT.COM

**Installation Instructions**  
**XRC 3.0 3,000lb Winch**  
**Part # 97203**

**XRC 3.0 (3,000lb) WINCH**

Specifications	
Rated line pull.	3000 Lbs (1360kgs) single line.
Motor.	Permanent magnetic DC 12V with 1.2 hp /0.9kw output
Gear.	Differential planetary
Gear ratio	153 : 1
Wire rope	3/16 " ×41' ( 4.8mm ×11m)
Drum size	1.25" ×2.86" ( 31.75mm×72mm)
Dimensions	L×W×H ( 300mm×105mm×105mm)
N W.	7.5 kg
G.W.	11 kg

Line Pull	lbs	0	1000	2000	3000
	kg	0	454	907	1361
Line Speed	ft/min	24.5	14.7	10.5	6.9
	m/min	7.5	4.5	3.2	2.1
Motor	Amps	15	75	120	175

**For Technical Support/Warranty Information please call 310-762-9944**

**Smittybilt, 400 West Artesia Blvd, Compton, CA 90220**





WWW.SMITTYBILT.COM

**Installation Instructions**  
**XRC 3.0 3,000lb Winch**  
**Part # 97203**

---

---

## Warranty

Smittybilt, Inc. offers a limited lifetime warranty (to the original retail purchaser) for each new Smittybilt consumer/RV electric winch against manufacturing defects in workmanship and materials on all the **mechanical** components.

**Electrical** components consisting of motors, solenoids, wiring, wire connectors and associated parts have a limited one (1) year warranty.

New cable assemblies are warranted against defects in workmanship and materials when received by the retail purchaser. There is no applicable warranty after initial use.

Warranty registration cards for each winch must be submitted at the time of purchase or within 30 days by the end user. Warranty will only be valid for the original purchaser of the winch and installed on the vehicle for which it was originally registered.

Smittybilt electric winches are intended for recreational self-recovery usage. The warranty is void if the winch is used in commercial/industrial applications.

The obligation under this warranty, statutory or otherwise, is limited to the replacement or repair at the manufacturer's factory, or at a point designated by the manufacturers, of such part(s) as shall appear to the manufacturer, upon inspection of such part(s) as shall appear to the manufacturer, upon inspection of such part(s), to have been defective in material of workmanship. This warranty does not obligate Smittybilt, Inc. to bear the cost of labor or transportation charges in connection with the replacement or repair of defective parts, nor shall it apply to a product upon which repairs or alterations have been made, unless authorized by the manufacturer, or for equipment misused, neglected or improperly installed.

### IMPORTANT NOTICE

To the fullest extent permitted by applicable law, the following are hereby excluded and disclaimed:

- 1) All warranties of fitness for a particular purpose;
- 2) All warranties of merchantability;
- 3) All claims for consequential or incidental damages.

There are no warranties that extend beyond the description that appears on the face hereof.

Some states do not allow the above exclusions or disclaimers in consumer transactions and as such this disclaimer/exclusion may not apply to you.

To the extent such warranties of fitness or merchantability are deemed to apply to this product, they exist for only so long as the express limited warranty elsewhere set forth is in existence.

Smittybilt, Inc. reserves the right to change, alter or improve its products in design, materials or appearance without incurring any obligation to incorporate such changes in products that were previously manufactured.

This Warranty gives you specific legal rights and you may have other legal rights, which vary from state to state. To submit a warranty claim contact:

**Smittybilt**  
**400 West Artesia Blvd**  
**Compton, CA 90220**  
**1-8888-717-5795**

**For Technical Support/Warranty Information please call 310-762-9944**

---

**Smittybilt, 400 West Artesia Blvd, Compton, CA 90220**



WWW.SMITTYBILT.COM

**Installation Instructions**  
XRC 3.0 3,000lb Winch  
Part # 97203

---

---

## Warranty Information Card

First name:

Last name:

Age: Sex:

City/Province:

Zip/Postal Code:

Country:

Telephone Number:

Email Address:

Which Smittybilt winch did you purchase?

Model Number:

Date of Purchase:

Where did you purchase this product?

Store or catalog name:

Store Location:

How satisfied were you with the dealer and/or sales staff?

Who installed or will install your Smittybilt product?

Is this the first time you have purchase a winch?

If no, what brand have you brought before?

What type of vehicle will this Smittybilt winch be installed on?

Year: Make: Model:

2WD: 4WD:

What is the vehicles main use?

What other accessories have you purchased for your vehicle?

**For Technical Support/Warranty Information please call 310-762-9944**

---

**Smittybilt, 400 West Artesia Blvd, Compton, CA 90220**