

RideCONTROL
by AIR LIFT.

Kits

59544/59568

***Ford F-150 Pickup &
Lincoln Mark LT***



*Cover illustration
may not depict
actual kit.*



INSTALLATION GUIDE

For maximum effectiveness and safety,
please read these instructions completely
before proceeding with installation.

*Failure to read these instructions can result in an
incorrect installation.*

TABLE OF CONTENTS

Introduction	2
Important Safety Notice	2
Notation Explanation	2
Installation Diagram	3
Hardware List	4
Tools List	4
Installing the RideControl System	4
Installing the Air Spring Kit	4
Installing the Air Lines	6
Checking for Leaks	7
Fixing Leaks	7
The Addition of Limiting Straps	8
Before Operating	9
Installation Checklist	9
Post-installation Checklist	9
Maintenance and Servicing	10
Minimum and Maximum Air Pressure	10
Maintenance Guidelines	10
Product Use	11
Frequently Asked Questions	11
Tuning the Air Pressure	11
Guidelines for Adding Air	12
Replacement Information	12
Contact Information	12
Warranty and Returns Policy	13

Introduction

The purpose of this publication is to assist with the installation, maintenance and troubleshooting of the RideControl air spring kit.

It is important to read and understand the entire installation guide before beginning installation or performing any maintenance, service or repair. The information here includes a hardware list, tool list, step-by-step installation information, maintenance tips, safety information and a troubleshooting guide.

Air Lift Company reserves the right to make changes and improvements to its products and publications at any time. For the latest version of this manual, contact Air Lift Company at (800) 248-0892 or visit our website at www.airliftcompany.com.

IMPORTANT SAFETY NOTICE

The installation of this kit does not alter the Gross Vehicle Weight Rating (GVWR) or payload of the vehicle. Check your vehicle's owner's manual and do not exceed the maximum load listed for your vehicle.

Gross Vehicle Weight Rating: The maximum allowable weight of the fully loaded vehicle (including passengers and cargo). This number — along with other weight limits, as well as tire, rim size and inflation pressure data — is shown on the vehicle's Safety Compliance Certification Label.

Payload: The combined, maximum allowable weight of cargo and passengers that the truck is designed to carry. Payload is GVWR minus the Base Curb Weight.

NOTATION EXPLANATION

Hazard notations appear in various locations in this publication. Information which is highlighted by one of these notations must be observed to help minimize risk of personal injury or possible improper installation which may render the vehicle unsafe. Notes are used to help emphasize areas of procedural importance and provide helpful suggestions. The following definitions explain the use of these notations as they appear throughout this guide.

 DANGER

INDICATES IMMEDIATE HAZARDS WHICH WILL RESULT IN SEVERE PERSONAL INJURY OR DEATH.

 WARNING

INDICATES HAZARDS OR UNSAFE PRACTICES WHICH COULD RESULT IN SEVERE PERSONAL INJURY OR DEATH.

 CAUTION

INDICATES HAZARDS OR UNSAFE PRACTICES WHICH COULD RESULT IN DAMAGE TO THE MACHINE OR MINOR PERSONAL INJURY.

NOTE

Indicates a procedure, practice or hint which is important to highlight.

Installation Diagram

Driver Side Shown

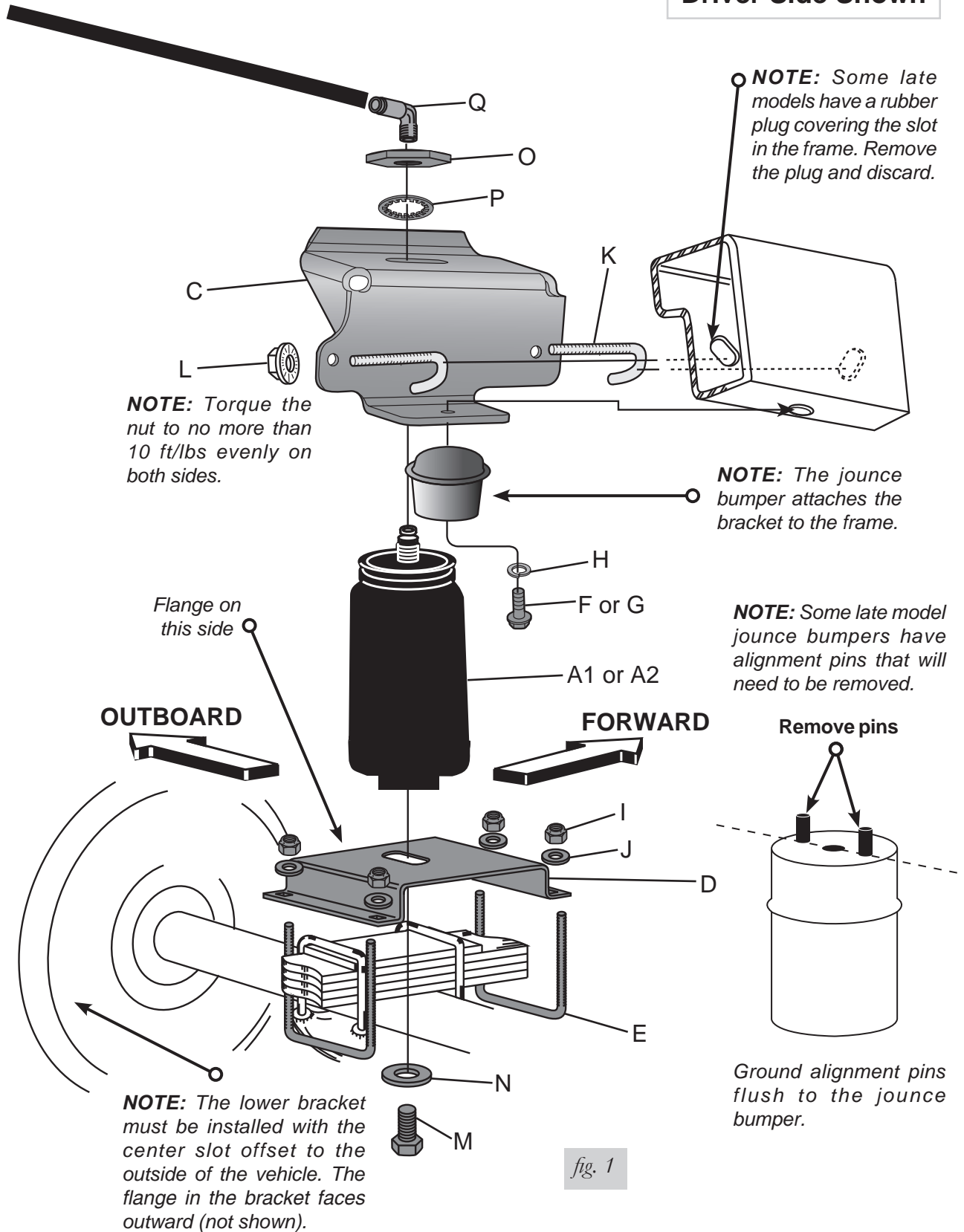

fig. 1

HARDWARE LIST

Item	Part #	Description.....Qty	Item	Part #	Description.....Qty
A1	58486	Air spring.....2	L	18422	3/8" Serrated flange nut.....4
A2	58571	Air spring.....2	M	17124	1/2" Bolt.....2
B	07028	Right upper bracket.....1	N	18414	1/2" Flat washer.....2
C	07329	Left upper bracket.....1	O	18454	3/4" Nylon nut.....2
D	03008	Lower bracket.....2	P	18450	3/4" Lock washer.....2
E	10583	3/8" U-bolt.....4	Q	21837	1/4" Elbow.....2
F	17297	M10-1.25 x 45 Bolt.....1	AA	20086 _{sub}	Air line assembly.....1
G	17330	M10-1.50 x 45 Bolt.....2	BB	10466	Zip tie.....6
H	18540	M10 Lock washer.....2	CC	21230	Valve cap.....2
I	18435	3/8" Nyloc nut.....8	DD	18405	5/16" Flat washer.....2
J	18444	3/8" Flat washer.....8	EE	21234	Rubber washer.....2
K	17309	3/8" J-bolt.....4	FF	18411	Star washer.....2
			GG	21233	5/16" Hex nut.....4



Missing or damaged parts? Call Air Lift customer service at (800) 248-0892 for a replacement part.

TOOLS LIST

Description.....Qty	Description.....Qty
Hoist or floor jacks.....1	Crescent wrench.....1
Safety stands.....2	Ratchet with 9/16", metric, & 1/2" deep well sockets.....1
Safety glasses.....1	Hose cutter, razor blade, or sharp knife.....1
Torque wrench.....1	Air compressor or compressed air source.....1
5/16" open-end or box wrench.....1	Spray bottle with dish soap/water solution.....1
7/16" open-end or box wrench.....1	
9/16" open-end or box wrench.....1	

Installing the RideControl System

INSTALLING THE AIR SPRING KIT

Your vehicle may be equipped with a rear brake proportioning valve. Any type of load assist product could affect brake performance. We recommend that you check with your dealer before installing this type of product. If your vehicle DOES NOT have a rear brake proportioning valve or is equipped with an anti-lock type brake system, installation of a load assist product will have NO EFFECT on brake performance.



UNBOLT THE LOWER BRACKET FROM THE LEAF SPRING IF THE VEHICLE IS TO BE SERVICED BY A FRAME CONTACT HOIST.

1. Remove the stock jounce bumper from under the frame (fig. 1).

NOTE

Some late model jounce bumpers have alignment pins that will need to be removed (fig. 1). Grind pins flush to the jounce bumper once removed.

2. Insert the J-bolts (K) through the upper bracket (B or C) with the curved part facing inboard.
3. Attach the lower portion of the upper bracket (B or C) to the frame using the stock jounce bumper. Secure in place with the supplied M10-1.25 x 45 bolt (F) or M10-1.50 x 45 bolt

(G) and M10 lock washer (H).

NOTE

The upper brackets are left- and right-side specific, designated by a "L" and "R" label.

4. Insert the curved part of the J-bolts (K) into the existing slots in the frame. Be sure the J-bolts lock onto the frame securely (fig. 2). Tighten the 3/8" serrated flange nut to attach.

NOTE

Some late models have a rubber plug covering the slot in the frame. Remove the plug and discard.

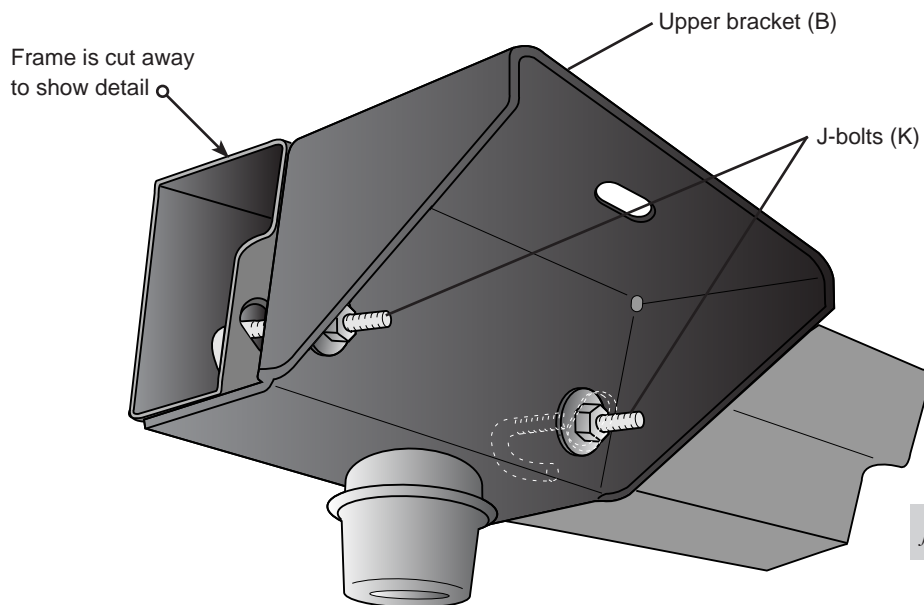
**NOTE**

Torque the bolts to no more than 10 ft/lbs evenly on both sides.

5. Cut the forward bolt flush to the nut.
6. Install the elbow fitting (Q) into the air port of the air sleeve. The fitting is pre-coated with thread sealant. Tighten finger tight plus two turns. Use a 7/16" open end wrench being careful to tighten on the metal hex nut only.

**CAUTION**

DO NOT OVERTIGHTEN.

7. Attach the air spring (A1 or A2) to the lower bracket (D) with the 1/2" flat washer (N) and lower mounting bolt (M). Leave loose for later adjustment.
8. Set the lower bracket on the leaf spring above the axle and attach using the supplied U-bolts (E), 3/8" flat washers (J), and 3/8" nyloc nuts (I) (fig. 1).
9. Guide the threaded post of the air fitting through the slot in the upper bracket.
10. Install the 3/4" nylon nut (O) and lock washer (P) on to the upper threaded post of the air spring. Leave loose for final adjustment.

INSTALLING THE AIR LINES

1. Choose a convenient location for mounting the inflation valves. Popular locations for the inflation valve are:
 - a. The wheel well flanges.
 - b. License plate recess in bumper.
 - c. Under the gas cap access door.
 - d. Through license plate itself.

NOTE

What ever the chosen location is, make sure there is enough clearance around the inflation valves for an air chuck.

2. Drill a 5/16" hole to install the inflation valves.
3. Cut the air line assembly (AA) in two equal lengths.

CAUTION

WHEN CUTTING OR TRIMMING THE AIR LINE, USE A HOSE CUTTER, A RAZOR BLADE OR A SHARP KNIFE. A CLEAN, SQUARE CUT WILL ENSURE AGAINST LEAKS. DO NOT USE WIRE CUTTERS OR SCISSORS TO CUT THE AIR LINE. THESE TOOLS MAY FLATTEN OR CRIMP THE AIR LINE, CAUSING IT TO LEAK AROUND THE O-RING SEAL INSIDE THE ELBOW FITTING (FIG. 3)

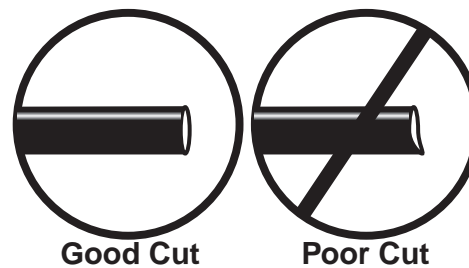

fig. 3

4. Place a 5/16" nut (GG) and a star washer (FF) on the air valve. Leave enough of the inflation valve in front of the nut to extend through the hole and have room for the rubber washer (EE), flat washer (DD), and 5/16" nut (GG) and cap (CC). There should be enough valve exposed after installation - approximately 1/2" - to easily apply a pressure gauge or an air chuck (fig. 4).
5. Push the inflation valve through the hole and use the rubber washer (EE), flat washer (DD), and another 5/16" nut (GG). Tighten the nuts to secure the assembly in place (fig. 4).

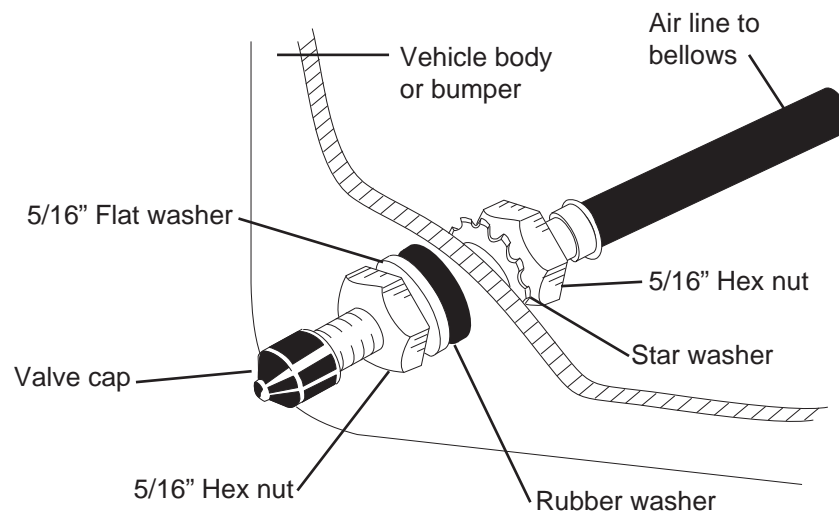
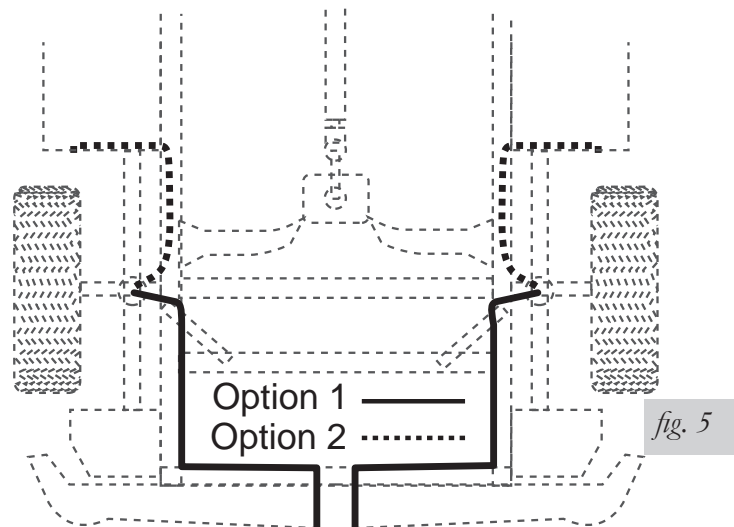

fig. 4

- Route the air line along the frame to the air fitting on the air spring (fig. 5). Keep AT LEAST 6" of clearance between the air line and heat sources, such as the exhaust pipes, muffler, or catalytic converter. Avoid sharp bends and edges. Use the plastic tie straps (BB) to secure the air line to fixed, non-moving points along the chassis. Be sure that the tie straps are tight, but do not pinch the air line. Leave at least 2" of slack to allow for any movement that might pull on the air line.



- Cut off air line leaving approximately 12" of extra air line. A clean square cut will ensure against leaks (see fig. 3). Insert the air line into the air fitting. This is a push to connect fitting. Simply push the air line into the 90° swivel fitting until it bottoms out (9/16" of air line should be in the fitting).
- IMPORTANT:** With the top and bottom still loose, inflate the air springs to approximately 10 PSI. Use the slots in the brackets to correctly align the air spring between the upper and lower brackets. this can be accomplished by tapping it inboard or outboard for proper alignment. There should be a symmetrical cushion of air around the base of the air spring when correctly positioned.

CHECKING FOR LEAKS

- Inflate the air spring to 30 PSI and spray all connections and the inflation valves with a solution of 1/5 liquid dish soap and 4/5 water to check for leaks. Spot leaks easily by looking for bubbles in the soapy water.
- After the test, deflate the springs to the minimum pressure required to restore the normal ride height, no less than 5 PSI.
- Check the air pressure again after 24 hours. A 2-4 PSI loss after initial installation is normal. Retest for leaks if the loss is more than 5 lbs.

FIXING LEAKS

- If there is a problem with the swivel fitting:
 - Check the air line connection by deflating the spring and removing the line by pulling the collar against the fitting and pulling firmly on the air line. Trim 1" off the end of the air line. Be sure the cut is clean and square (see fig. 12). Reinsert the air line into the push-to-connect fitting.
 - Check the threaded connection by tightening the swivel fitting another ½ turn. If it still leaks, deflate the air spring, remove the fitting, and re-coat the threads with thread sealant. Reinstall by hand tightening as much as possible, then use a wrench for an additional two turns.

2. If there is a problem with the inflation valve, then:
 - a. Check the valve core by tightening it with a valve core tool.
 - b. Check the air line connection by removing the air line from the barbed type fitting.

CAUTION

DO NOT CUT THE AIR LINE COMPLETELY OFF AS THIS WILL NICK THE BARB AND RENDER THE FITTING USELESS.

3. If the preceding steps have not resolved the problem, call Air Lift customer service at (800) 248-0892 for assistance.

THE ADDITION OF LIMITING STRAPS

If you intend to use the truck off-road or in situations where the suspension is extended, it will be necessary to install limiting straps due to the long extension travel of the rear suspension.

CAUTION

IF LIMITING STRAPS ARE NOT INSTALLED FOR VEHICLES USED OFF-ROAD, THE SUSPENSION COULD PULL THE AIR SPRINGS APART. THE DAMAGE TO THE AIR SPRINGS WILL NOT BE COVERED BY THE WARRANTY.

To determine the type of limiting straps needed for your vehicle:

1. Jack the vehicle up using the hitch or frame.
2. Measure the distance between the upper and lower air spring mounting brackets. (Maximum extension on the air spring is 10" or slightly longer.)
3. Then measure from the center of one shock bolt to the center of the other. (This is a common place to mount the limiting straps). This is the length needed to limit your suspension from overextension.
4. Contact your local auto parts retailer to purchase limiting straps in the correct length for your vehicle.
5. Follow the manufacturer's directions on installing the limiting straps.

Before Operating

INSTALLATION CHECKLIST

- Clearance test — Inflate the air springs to 60 PSI and make sure there is at least ½” clearance from anything that might rub against each sleeve. Be sure to check the tire, brake drum, frame, shock absorbers and brake cables.
- Leak test before road test — Inflate the air springs to 30 PSI and check all connections for leaks. Refer to “Checking for Leaks” on page 7. All leaks must be eliminated before the vehicle is road tested.
- Heat test — Be sure there is sufficient clearance from heat sources, at least 6” for air springs and air lines. If a heat shield was included in the kit, install it. If there is no heat shield, but one is required, call Air Lift customer service at (800) 248-0892.
- Fastener test — Recheck all bolts for proper torque.
- Road test — The vehicle should be road tested after the preceding tests. Inflate the springs to 25 PSI (50 PSI if the vehicle is loaded). Drive the vehicle 10 miles and recheck for clearance, loose fasteners and air leaks.
- Operating instructions — If professionally installed, the installer should review the operating instructions with the owner. Be sure to provide the owner with all of the paperwork that came with the kit.

Technician's Signature _____

Date _____

POST-INSTALLATION CHECKLIST

- Overnight leak down test — Recheck air pressure after the vehicle has been used for 24 hours. If the pressure has dropped more than 5 PSI, then there is a leak that must be fixed. Either fix the leak yourself or return to the installer for service.
- Air pressure requirements — I understand the air pressure requirements of my air spring system. Regardless of load, the air pressure should always be adjusted to maintain ride height at all times.
- Thirty day or 500 mile test — I understand that I must recheck the air spring system after 30 days or 500 miles, whichever comes first. If any part shows signs of rubbing or abrasion, the source should be identified and moved, if possible. If it is not possible to relocate the cause of the abrasion, the air spring may need to be remounted. If professionally installed, the installer should be consulted. Check all fasteners for tightness.

Maintenance and Servicing

Minimum Air Pressure	Maximum Air Pressure
5 PSI	100 PSI
FAILURE TO MAINTAIN CORRECT MINIMUM PRESSURE (OR PRESSURE PROPORTIONAL TO LOAD), BOTTOMING OUT, OVER-EXTENSION OR RUBBING AGAINST ANOTHER COMPONENT WILL VOID THE WARRANTY.	

MAINTENANCE GUIDELINES

NOTE

By following these steps, vehicle owners will obtain the longest life and best results from their air spring.

1. Check the air pressure weekly.
2. Always maintain normal ride height. Never inflate beyond 100 PSI.
3. If you develop an air leak in the system, use a soapy water solution to check all air line connections and the inflation valve core, before deflating and removing the spring.
4. When increasing load, always adjust the air pressure to maintain normal ride height. Increase or decrease pressure from the system as necessary to attain normal ride height for optimal ride and handling. Remember that loads carried behind the axle (including tongue loads) require more leveling force (pressure) than those carried directly over the axle.

CAUTION

FOR YOUR SAFETY AND TO PREVENT DAMAGE TO YOUR VEHICLE, DO NOT EXCEED MAXIMUM GROSS VEHICLE WEIGHT RATING (GVWR), AS INDICATED BY THE VEHICLE MANUFACTURER. ALTHOUGH YOUR AIR SPRINGS ARE RATED AT A MAXIMUM INFLATION PRESSURE OF 100 PSI, THE AIR PRESSURE ACTUALLY NEEDED IS DEPENDENT ON YOUR LOAD AND GVWR.

5. Always add air to the springs in small quantities, checking the pressure frequently. Sleeves require less air volume than a tire and inflate quickly.
6. Should it become necessary to raise the vehicle by the frame, make sure the system is at a minimum pressure (5 PSI) to reduce tension on the suspension/brake components. Use of on-board leveling systems do not require deflation or disconnection.

Troubleshooting Guide

1. Leak test the air line connections, threaded connection of the elbow into the air spring, and the inflation valves. See "Fixing Leaks" on page 10 for repair.
2. Check for dirt debris in the valve core.
3. Inspect the air lines to be sure none are pinched. Tie straps may be too tight. Loosen or replace the strap and replace leaking components.
4. Inspect the air line for holes and cracks. Replace as needed.
5. Look for a kink or fold in the air line. Reroute as needed.

If the preceding steps do not solve the problem, it is most likely caused by a failed air spring — either a factory defect or an operating problem. Please call Air Lift at (800) 248-0892 for assistance or a replacement air spring.

Product Use

FREQUENTLY ASKED QUESTIONS

Q. Will installing air springs increase the weight ratings of a vehicle?

No. Adding air springs will not change the weight ratings (GAWR, GCWR and/or GVWR) of a vehicle. Exceeding the GVWR is dangerous and voids the Air Lift warranty.

Q. Is it necessary to keep air in the air springs at all times and how much pressure will they need?

The minimum air pressure should be maintained at all times. The minimum air pressure keeps the air spring in shape, ensuring that it will move throughout its travel without rubbing or wearing on itself.

Q. Is it necessary to add a compressor system to the air springs?

No. Air pressure can be adjusted with any type of compressor as long as it can produce sufficient pressure to service the springs. Even a bicycle tire pump can be used, but it's a lot of work.

Q. How long should air springs last?

If the air springs are properly installed and maintained they can last indefinitely.

Q. Will raising the vehicle on a hoist for service work damage the air springs?

No. The vehicle can be lifted on a hoist for short-term service work such as tire rotation or oil changes. However, if the vehicle will be on the hoist for a prolonged period of time, support the axle with jack stands in order to take the tension off of the air springs.

TUNING THE AIR PRESSURE

Pressure determination comes down to three things — level vehicle, ride comfort, and stability.

1. Level vehicle

If the vehicle's headlights are shining into the trees or the vehicle is leaning to one side, then it is not level (fig. 6). Raise the air pressure to correct either of these problems and level the vehicle.

2. Ride comfort

If the vehicle has a rough and harsh ride it may be due to either too much pressure or not enough (fig. 7). Try different pressures to determine the best ride comfort.

3. Stability

Stability translates into safety and should be the priority, meaning the driver may need to sacrifice a perfectly level and comfortable ride. Stability issues include roll control, bounce, dive during braking and sponginess (fig. 8). Tuning out these problems usually requires an increase in pressure.



Bad headlight aim

fig. 6



Rough ride

fig. 7



Sway and body roll

fig. 8

GUIDELINES FOR ADDING AIR

1. Start with the vehicle level or slightly above.
2. When in doubt, always add air.
3. For motorhomes, start with 50-100 PSI in the rear because it can be safely assumed that it is heavily loaded.
4. If the front of the vehicle dives while braking, increase the pressure in the front air bags, if equipped.
5. If it is ever suspected that the air bags have bottomed out, increase the pressure (fig. 9).
6. Adjust the pressure up and down to find the best ride.
7. If the vehicle rocks and rolls, adjust the air pressure to reduce movement.
8. It may be necessary to maintain different pressures on each side of the vehicle. Loads such as water, fuel, and appliances will cause the vehicle to be heavier on one side (fig. 10). As much as a 50 PSI difference is not uncommon.



Bottoming out

fig. 9

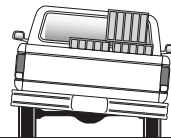

Unlevel

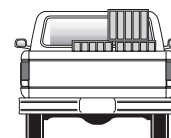

Level

fig. 10

Replacement Information

If you need replacement parts, contact the local dealer or call Air Lift customer service at (800) 248-0892. Most parts are immediately available and can be shipped the same day.

Contact Air Lift Company customer service at (800) 248-0892 first if:

- Parts are missing from the kit.
- Need technical assistance on installation or operation.
- Broken or defective parts in the kit.
- Wrong parts in the kit.
- Have a warranty claim or question.

Contact the retailer where the kit was purchased:

- If it is necessary to return or exchange the kit for any reason.
- If there is a problem with shipping if shipped from the retailer.
- If there is a problem with the price.

Contact Information

If you have any questions, comments or need technical assistance contact our customer service department by calling (800) 248-0892, Monday through Friday, 8 a.m. to 8 p.m. Eastern Time. For calls from outside the USA or Canada, our local number is (517) 322-2144.

For inquiries by mail, our address is PO Box 80167, Lansing, MI 48908-0167. Our shipping address for returns is 2727 Snow Road, Lansing, MI 48917.

You may also contact us anytime by e-mail at sales@airliftcompany.com or on the web at www.airliftcompany.com.

Warranty and Returns Policy

Air Lift Company warrants its products, for the time periods listed below, to the original retail purchaser against manufacturing defects when used on catalog-listed applications on cars, vans, light trucks and motorhomes under normal operating conditions for as long as Air Lift manufactures the product. The warranty does not apply to products that have been improperly applied, improperly installed, used in racing or off-road applications, used for commercial purposes, or which have not been maintained in accordance with installation instructions furnished with all products. The consumer will be responsible for removing (labor charges) the defective product from the vehicle and returning it, transportation costs prepaid, to the dealer from which it was purchased or to Air Lift Company for verification.

Air Lift will repair or replace, at its option, defective products or components. A minimum \$10.00 shipping and handling charge will apply to all warranty claims. Before returning any defective product, you must call Air Lift at (800) 248-0892 in the U.S. and Canada (elsewhere, (517) 322-2144) for a Returned Materials Authorization (RMA) number. Returns to Air Lift can be sent to: Air Lift Company • 2727 Snow Road • Lansing, MI • 48917.

Product failures resulting from abnormal use or misuse are excluded from this warranty. The loss of use of the product, loss of time, inconvenience, commercial loss or consequential damages is not covered. The consumer is responsible for installation/reinstallation (labor charges) of the product. Air Lift Company reserves the right to change the design of any product without assuming any obligation to modify any product previously manufactured.

This warranty gives you specific legal rights and you may also have other rights that vary from state-to-state. Some states do not allow limitations on how long an implied warranty lasts or allow the exclusion or limitation of incidental or consequential damages. The above limitation or exclusion may not apply to you. There are no warranties, expressed or implied including any implied warranties of merchantability and fitness, which extend beyond this warranty period. There are no warranties that extend beyond the description on the face hereof. Seller disclaims the implied warranty of merchantability. (Dated proof of purchase required.)

Air Lift 1000	Lifetime Limited	LoadController/Dual	2 Year Limited
RideControl	Lifetime Limited	Load Controller (I)	2 Year Limited
LoadLifter 5000*	Lifetime Limited	Load Controller (II)	2 Year Limited
SlamAir	Lifetime Limited	SmartAir	2 Year Limited
AirCell	Lifetime Limited	Wireless AIR	2 Year Limited
Air Lift Performance**	1 Year Limited	WirelessONE	2 Year Limited
LoadController/Single	2 Year Limited	Other Accessories	2 Year Limited

**formerly SuperDuty*

***formerly EasyStreet and LifeStyle & Performance*

Need Help?

Contact our customer service department by calling (800) 248-0892, Monday through Friday. For calls from outside the USA or Canada, our local number is (517) 322-2144.

**Register your warranty online at
www.airliftcompany.com/warranty**



Thank you for purchasing Air Lift products — the professional installer's choice!

Air Lift Company • 2727 Snow Road • Lansing, MI 48917 or PO Box 80167 • Lansing, MI 48908-0167
Toll Free (800) 248-0892 • Local (517) 322-2144 • Fax (517) 322-0240 • www.airliftcompany.com

Printed in
the USA