

PSHS-XXXX-10

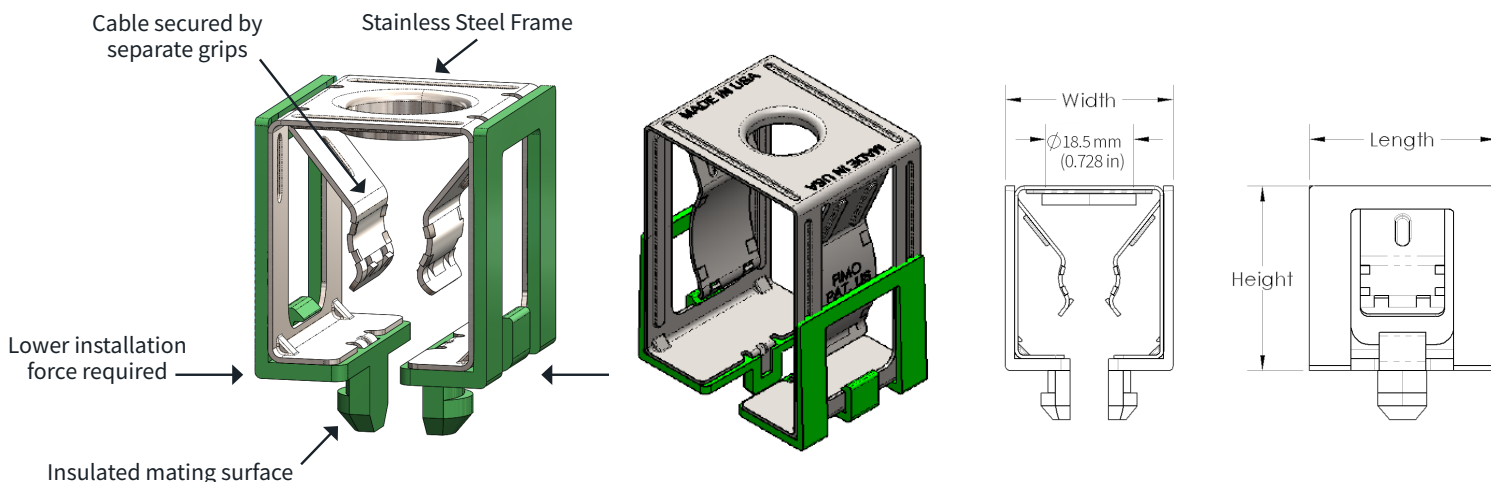

**SPECIFICATIONS**

For patents see [www.cf-pat.com](http://www.cf-pat.com)

<b>General</b>	PIM Shield Hybrid Snap-ins provide a low passive intermodulation method to secure RF, fiber, power and RET cables in high risk PIM zones. ConcealFab's Patent Pending design provides insulation at the mating surfaces to prevent undesired metal-to-metal contact.
<b>Mounting</b>	Hybrid Snap-ins are designed to insert into support bars (sold separately) that are 0.118-inch to 0.169-inch thick with 0.71-inch to 0.76-inch diameter holes. ConcealFab offers a variety of low PIM Support Bar options for use in the high risk PIM zone.
<b>System PIM performance (when tested at next higher assembly)</b>	IM3 <-100 dBm when tested in accordance with proposed IEC 62037-8, near field test, 2x 20W test tones, while subjected to dynamic stimulus
<b>Material</b>	Frame – Stainless steel Insulation - UV stable, glass filled Nylon
<b>Plastic Color</b>	Green
<b>Operating Temperature</b>	-40°C to +70°C
<b>Quantity per Package</b>	10

Part Number	Description	Cable Diameter	Height	Length	Width
PSHS-1319-10	PIM Shield Hybrid Snap-In, 13 to 19 mm (1/2 in)	13 to 19 mm	40 mm (1.57 in)	40 mm (1.57 in)	36 mm (1.42 in)
PSHS-2630-10	PIM Shield Hybrid Snap-In, 26 to 30 mm (7/8 in)	26 to 30 mm	40 mm (1.57 in)	40 mm (1.57 in)	36 mm (1.42 in)
PSHS-3642-10	PIM Shield Hybrid Snap-In, 36 to 42 mm (1-1/4 in)	36 to 42 mm	75.3 mm (2.96 in)	45 mm (1.77 in)	62 mm (2.44 in)
PSHS-4852-10	PIM Shield Hybrid Snap-In, 48 to 52 mm (1-5/8 in)	48 to 52 mm	75.3 mm (2.96 in)	45 mm (1.77 in)	62 mm (2.44 in)