



**TP&E National
RAN Field Notice**

RF Product General Availability Notice

Product Name : ANT_Laird_CMD69423P
Product Description : MULTI-BAND MIMO CEILING MOUNT ANTENNA
ATT Nomenclature : [LHC]B-[2]P-[2LHC]A-[VH]

HQ TP&E RAN_ET Contact: Ming Ho (mh8532), Effendi Jubilee (ej9883)
HQ CTO RAN Contact: Shane Morrison (pm6337)
HQ TP&E RAN_Design Contact: Robert Clark (rc6164), Olumide Ajayi (oa5860)
HQ SCM Contact: Jeremy Lara (jl8840)
HQ C&E Contact: Scott Whitney (sw1707)
HQ TP&E Asset Opt. Contact: Ben Simon (bs8514)

Review & Approval Committee

Ben Simon	Olumide Ajayi
Biggs, Troy D	Rob Seawright
Derrick Smith	Robert Clark
Effendi Jubilee	Ron Oliver
Ian Rochester	Scott Whitney
Jeremy Lara	Shane Morrison
Julius Fodje	Thomas Land
Kip Turner	Vicki Littlefield
Matt Karcher	William Frazier
Ming-ju Ho	Saadij Haque

Date: **July 29, 2020**

Summary: The following Laird MULTI-BAND MIMO CEILING MOUNT Antenna has achieved General Availability Status.

Description of product(s) being made Generally Available:

Model/Part Number	Item Master Number	Description
CMD69423P-30D43F	ANT.47465	698-960 MHz / 1300-4200 MHz (AWS-3, WCS, CBRS Band and Full C-Band support), 2-Port MIMO CEILING MOUNT ANTENNA, 4.3-10 Female

Rationale/How is the product used?

- These antennas support ultra-broadband operation: 700MHz (B12/17, B29, B14), 850MHz, PCS, AWS-1 & 3, WCS and B48 (3.5G) and Full C-Band. Antenna pattern files are available in Atoll antenna library.

F:\GlobalData\Antenna_Library

All antenna comparison information such as patterns and SPR can be found in the root directory of the antenna library on the Atoll server.

- **This antenna utilizes two 4.3-10 female connector**

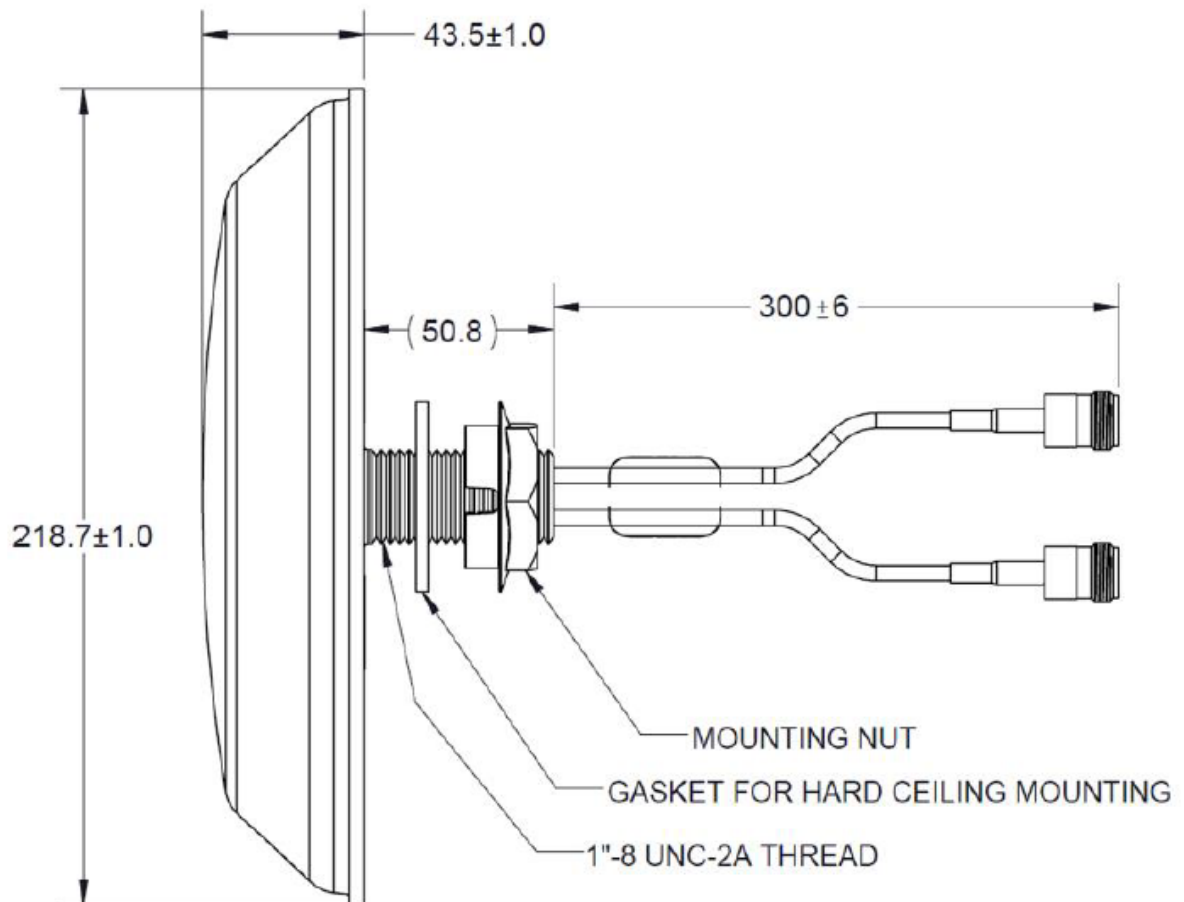

- **This antenna has 2 arrays: Linier Horizontal. IM analysis must be performed to ensure no IM3 when transmit multiple carriers into the same antenna array. For detail IM guidance, please refer to IM Guidelines ATT-002-290-319 [10].**
- Input Power per Port: 50W
- VSWR-max= 1.8 - 2.0 depends on freq. band; PIM= < -150 dBc
- B14, B29 and/or B12/17 deployment shall not be in the same physical Radome, please refer to the

© 2020 AT&T

AT&T Proprietary (Internal Use Only) Not for use or disclosure outside the AT&T companies, except under written agreement.

Collocation Guideline, ATT-002-290-105

- Due to close connector spacing, traditional Butyl/tape weatherproofing may be challenging. It is recommended to use an approved closure type device (“clam shell”), cold shrink or jumper boot for weatherproofing. Unused antenna ports shall be protected with an appropriately sized protective cap which includes an O-ring. The cap shall have tape applied to protect the connector threads and ensure the cap remains attached over time.
- Dimensions: 1.71” (L) x 8.6” (Diameter)
- Net Weight: 0.95 lbs

Additional Information/Technical References

➤ Identification and Treatment of Assets Removed from Service

The goal of the Mobility Network Asset Acceleration program is to manage, minimize financial impact when the business dictates a high probability a network element(s) will be retired prior to the end of its useful life. In-Service RAN equipment associated with pre-identified company directed decommission initiatives, not defined by the enterprise for reuse or sparing will qualify for accelerated depreciation treatment when retired. Eligible items must meet one of the following criteria:

- Part of a Technology turndown (e.g. TDMA, GSM, and CDMA)
- Part of an exception process (Battery Replacement, Antenna Turndown)
- On the Excess & Obsolete list
 - Item/part numbers that are on the E&O list are preapproved for retirement

Please note:

- Idle/spare equipment, Destroyed/Damaged Sites, Cancelled Projects are not eligible for re-class to depreciation expense

➤ Refer to website: [RF Hardware Equipment Engineering](#) for more detailed information:

1. Approved Antenna List
2. Datasheets
3. Qualification test reports
4. [4T4R Antenna Radio Port Connections](#) (RF-HW-2016-234)
5. Collocation Guideline, ATT-002-290-105
6. Antenna Guidelines, ATT-002-290-106
7. RET Guidelines, ATT-002-290-125
8. PIM Measurement MOP, ATT-002-290-316
9. Antenna/Cable System Sweep MOP, ATT-002-290-043
10. UMTS RF Design Guidelines, ATT-002-290-278
11. LTE RF Design Guidelines, ATT-002-290-329
12. IM Analysis, ATT-002-290-319
13. Weatherproofing guidelines, ATT-002-290-041

Vendor Contact Information

Steve Bruegger	214-668-8860	Steven.Bruegger@lairdconnect.com
----------------	--------------	----------------------------------