

MT-221L

Adjustable Wall Mount for hollow walls, 12 in stand-off

Product Classification

Product Type Wall mount kit

General Specifications

Mounting Hollow walls

Dimensions

Height 203.2 mm | 8 in

Width 203.2 mm | 8 in

Length 304.8 mm | 12 in

Pipe Outer Diameter 114.3 mm | 4.5 in | 60.96 mm | 2.4 in | 73.66 mm | 2.9 in | 88.9 mm | 3.5 in

Stand-off Distance 304.8 mm | 12 in

MT-221L

Outline Drawing

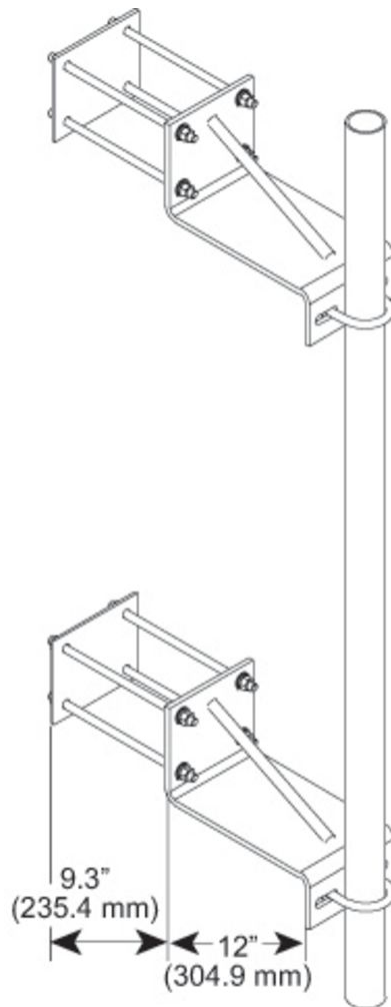

Material Specifications

Material Type Hot dip galvanized steel

Mechanical Specifications

Wind Rating For Specifications, please contact steelproducts@commscope.com or call 800-255-1479

Packaging and Weights

Included Backing plates or anchors | Wall brackets (2)

Packaging quantity 2

Weight, net 34.2 kg | 75.398 lb

MT-221L

Regulatory Compliance/Certifications

Agency

ISO 9001:2015

**Classification**

Designed, manufactured and/or distributed under this quality management system

* Footnotes

Wind Rating

BWS—w Base Wind Speed; FBC—Florida Building Code