

# P-100

---

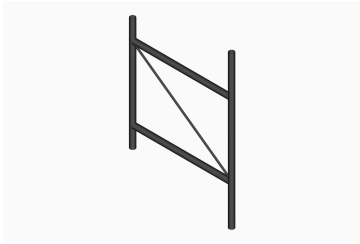

Panel Antenna Stand-Off Bracket, 12 in

## Product Classification

**Product Type** Stand-off mount

## General Specifications

**Note** One 72 in x 8 in panel antenna per sector

## Dimensions

**Height** 1778 mm | 70 in

**Width** 76.2 mm | 3 in

**Length** 304.8 mm | 12 in

**Stand-off Distance** 304.8 mm | 12 in

# P-100

## Outline Drawing

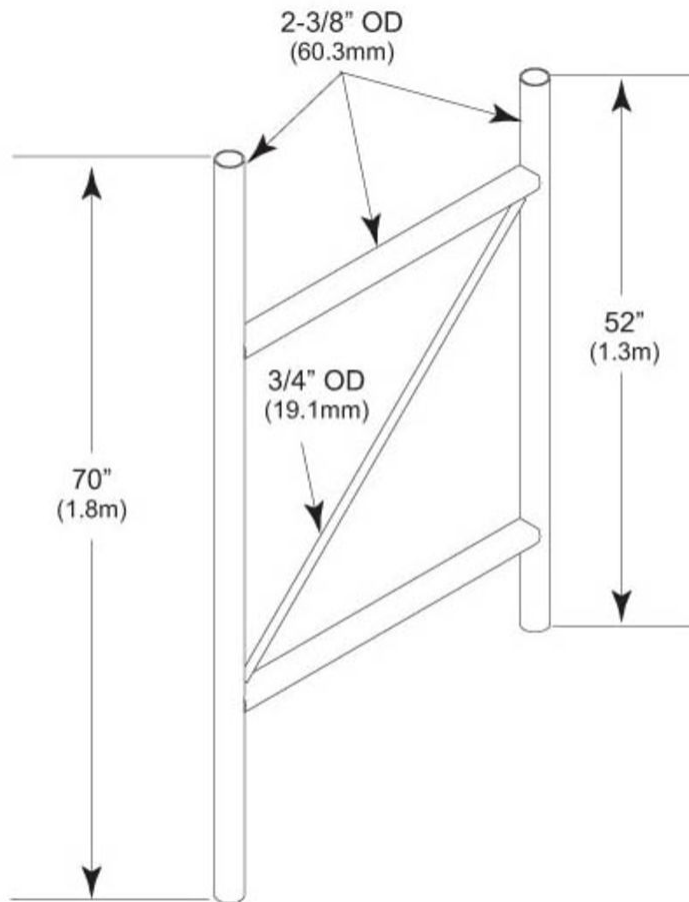

## Material Specifications

**Material Type** Hot dip galvanized steel

## Mechanical Specifications

**Wind Rating** 120 mph (BWS) at 150 ft AGL

**Wind Rating Test Method** TIA/EIA-222

## Packaging and Weights

**Included** Stand-off

**Packaging quantity** 1

# P-100

---

**Weight, net**

19 kg | 41.888 lb

## Regulatory Compliance/Certifications

**Agency**

CHINA-ROHS

ISO 9001:2015

REACH-SVHC

ROHS

**Classification**

Below maximum concentration value

Designed, manufactured and/or distributed under this quality management system

Compliant as per SVHC revision on [www.commscope.com/ProductCompliance](http://www.commscope.com/ProductCompliance)

Compliant



## \* Footnotes

**Wind Rating**

BWS—w Base Wind Speed; FBC—Florida Building Code