

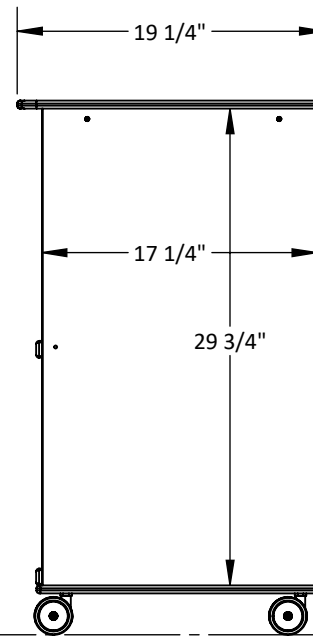

Drawer Inside Dimensions:
 W - 11 1/2
 H - 3 1/2
 D - 15 7/5

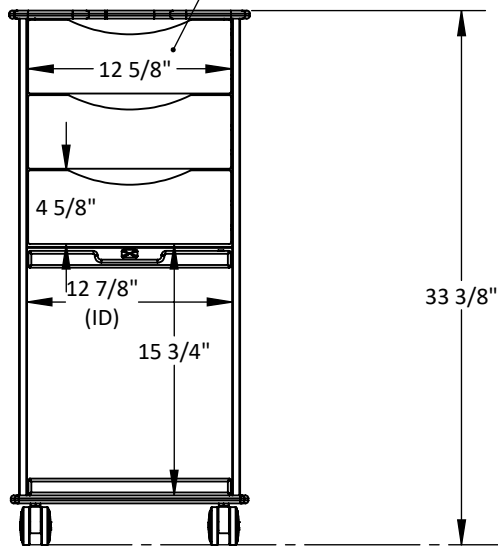

<p>PROPRIETARY AND CONFIDENTIAL</p> <p>THE INFORMATION CONTAINED IN THIS DRAWING IS THE SOLE PROPERTY OF TRIPPNT. ANY REPRODUCTION IN PART OR AS A WHOLE WITHOUT THE WRITTEN PERMISSION OF TRIPPNT IS PROHIBITED.</p>			<p>DIMENSIONS ARE IN INCHES</p> <p>TOLERANCES:</p> <p>FRACTIONAL ± 1/8"</p> <p>ANGULAR: MACH ± BEND ±</p> <p>TWO PLACE DECIMAL ±</p> <p>THREE PLACE DECIMAL ±</p> <p>Outside dimensions rounded up to nearest 1/8"; inside dimensions rounded down to nearest 1/8"</p>	<table border="1"> <tr> <td></td> <td>NAME</td> <td>DATE</td> </tr> <tr> <td>DRAWN</td> <td>JH</td> <td>4/22/21</td> </tr> <tr> <td>CHECKED</td> <td></td> <td></td> </tr> <tr> <td>ENG APPR.</td> <td></td> <td></td> </tr> <tr> <td>MFG APPR.</td> <td></td> <td></td> </tr> <tr> <td>Q.A.</td> <td></td> <td></td> </tr> </table>		NAME	DATE	DRAWN	JH	4/22/21	CHECKED			ENG APPR.			MFG APPR.			Q.A.			 <p>This document and the information contained therein are the property of TRIPPNT, Kansas City, Missouri. Recipient agrees NOT TO: (1) Use such information for purposes other than those expressly authorized by TRIPPNT. (2) Furnish such information to any other person in whole or in part for any purpose whatsoever without express written permission of TRIPPNT. (3) Reproduce or copy this document either in whole or in part without the express written permission of TRIPPNT.</p>
		NAME	DATE																				
	DRAWN	JH	4/22/21																				
	CHECKED																						
ENG APPR.																							
MFG APPR.																							
Q.A.																							
NEXT ASSY	USED ON	MATERIAL	<p>COMMENTS:</p>																				
		HDPE, PETG, ABS																					
		FINISH																					
		Smooth, no rough edges		<table border="1"> <tr> <td>SIZE</td> <td>DWG. NO.</td> <td>REV.</td> </tr> <tr> <td>A</td> <td>21 - 51726.1</td> <td>10</td> </tr> </table>	SIZE	DWG. NO.	REV.	A	21 - 51726.1	10													
SIZE	DWG. NO.	REV.																					
A	21 - 51726.1	10																					
APPLICATION		DO NOT SCALE DRAWING	Weight: 60 lbs	SHEET 1 OF 1																			