

Installation Instructions to Install a KM 1000/1003 Air Suspension in a John Deere 8000 Series Tractor

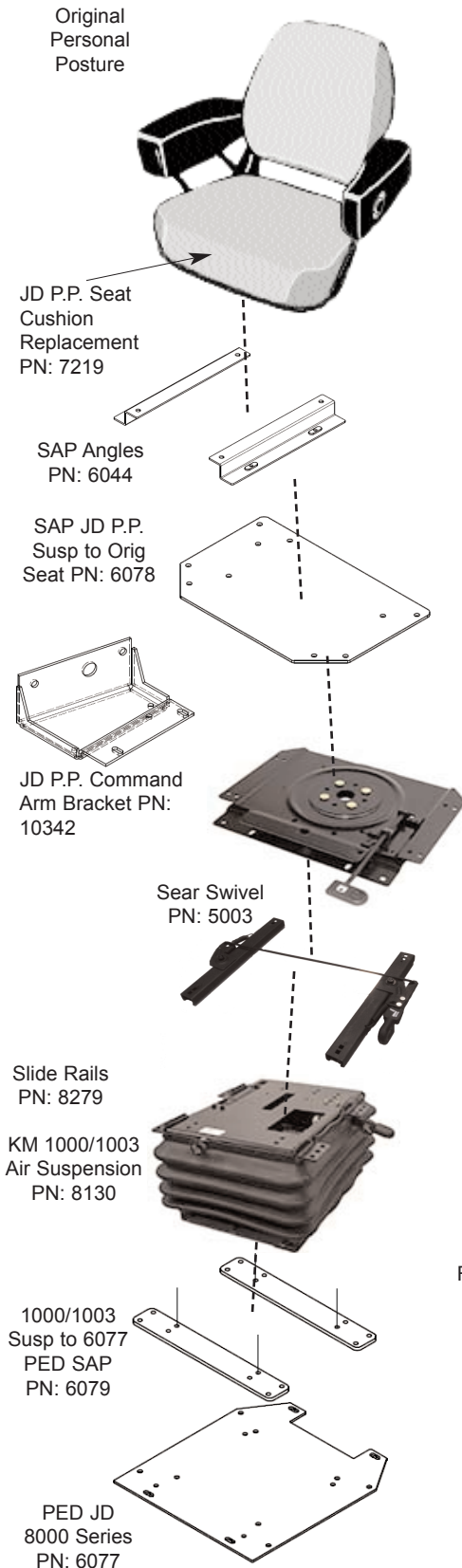

1. Unplug power connector from back side of the seat by the lower corner of the cab.
2. Remove the original seat and suspension. Keep the original 8mm mounting bolts. Mount the 6077 plate to the pedestal in the cab using the original bolts.
3. Outside of the cab, attach plates 6079 to the bottom of the suspension PN: 8130 using the 8mm x 20mm flat head socket cap bolts. The plates should form a 15" wide by 11-13/16" front to back bolt pattern outside of the suspension profile.
4. Tie the two slide rails together by attaching the connecting rod to the slide rails. Mount the slide rails PN: 8279 to the top of the suspension using four 5/16" x 5/8" socket head bolts and flange nuts. The slide rail adjustment handle goes to the left.
5. Install the swivel PN: 5003 on to the slide rails using four 5/16" x 5/8" bolts and flange nuts. Run the bolts from the bottom up.
6. Install the suspension assembly with the 6079 plates, Slide Rails, and Swivel into the tractor and fasten to the 6077 plate using four 3/8" x 1" bolts and flange nuts.
7. Outside of the cab, replace the old seat cushion with the new one included PN: 7219. Remove the old operator presence switch (JD PN: RE43526) from the old seat and install it in the new cushion. Fasten the SAP Angles to the seat with four 5/16" x 3/4" bolts and lock washers.
8. Fasten the JD P.P. Command Arm Bracket to the SAP 6078 using two 5/16" x 3/4" bolts and flange nuts. Do not tighten. See detail below.
9. Fasten the SAP 6078 to the SAP Angles using four 5/16" x 3/4" bolts and lock washers. The rear bolt will run through the JD P.P. Command Arm.
10. Move the seat into the tractor and fasten it to the suspension assembly. You will use two of the four 1" tube spacers, four 5/16" x 1 3/4" bolts, and flange nuts that came with the swivel. The tube spacers go in between the swivel and the SAP 6078 on the left side. The JD P.P. Command arm bracket will act as the spacer on the right. Run the bolts from the bottom up. The bolts go in the inner four holes of the swivel. It may help to put the run the bolts through the swivel first then install the seat assembly.
11. Tighten all hardware. Mount your command arm to the Command Arm Bracket with the two 12mm bolts provided.
12. Connect the wiring harness that was included to the seat and suspension and then to the tractor. The red and black wires go to the suspension and the green and yellow to the seat.

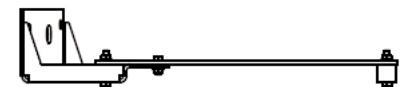
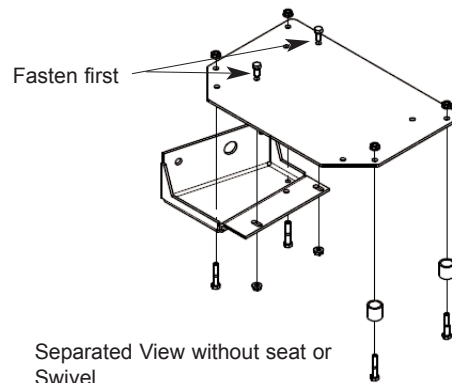

Front View without seat or swivel

JD P.P. Command Arm Bracket to 6078 Details