

UPLAY TODAY™

PLAY SYSTEMS

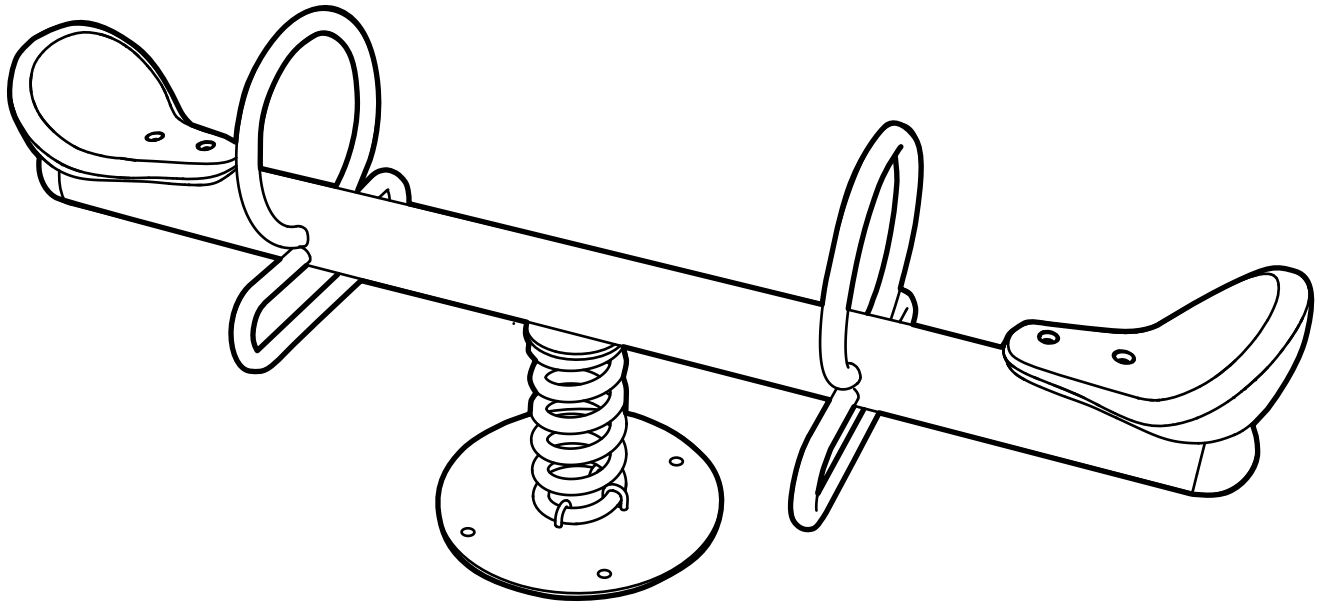

MODEL # 02-07-0055

See Saw

**ASSEMBLY
INSTRUCTIONS**

DETAILS PAGE (Surface Mount)

FOOTING DETAIL

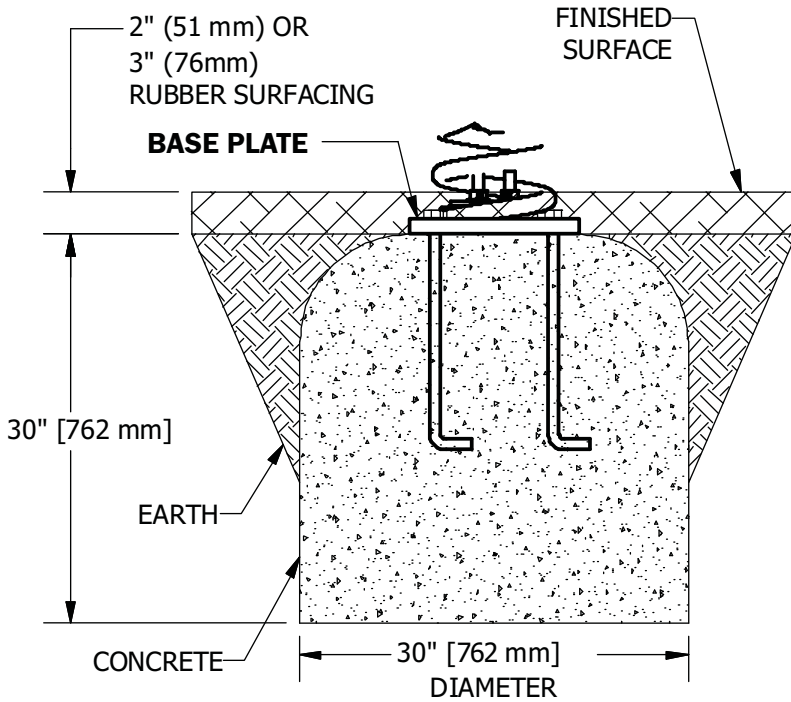

NOTE:

- Hole depths indicated on all ground plans are measured from the finished surface. See *Footing Detail*.

- All Footer dimensions are based on level finished surface.

Concrete Required :
 Approx. .5 Cubic Yards (.35 Cubic Meters)
 Suggested Min. concrete rating: 3000PSI

USE ZONE: 12'(3658mm) x 19'(5791mm)

Top View

Note: Use zones can overlap for sitting type of equipment only if designated play surface height is 30"(762mm) or less.

Spring Riders and See Saw can be placed 6'(152mm) apart.

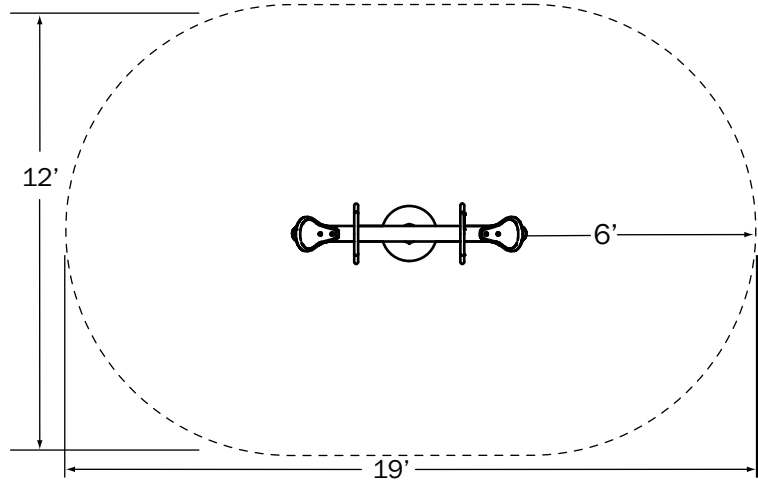

Specifications:

- Pipe Arm:** 5" Diameter(128mm) galvanized pipe, powder coated after fabrication.
- Handles/Foot Rests:** Formed from 1.0625(30mm) Galvanized Pipe, powder coated after fabrication.
- Spring:** Free height 13"(32mm), 6"(146mm) O.D. steel tempered, powder-coated.
- Seats:** Molded polyethylene
- Hardware:** Primary hardware is stainless steel.
- Base:** 3/16" thick steel plate, powder coated after fabrication.
- Wt:** 90lbs.

INSTRUCTIONS (Surface Mount)

Parts List			
Letter	Description	Quantity	Part Number
	Hardware Complete	1	33-12-0064
A	1/2"x10-1/2" Anchor Bolt	4	33-11-0703
B	1/2" Flat Washer	4	33-02-0003
C	1/2" Hex Nut	4	33-01-0004

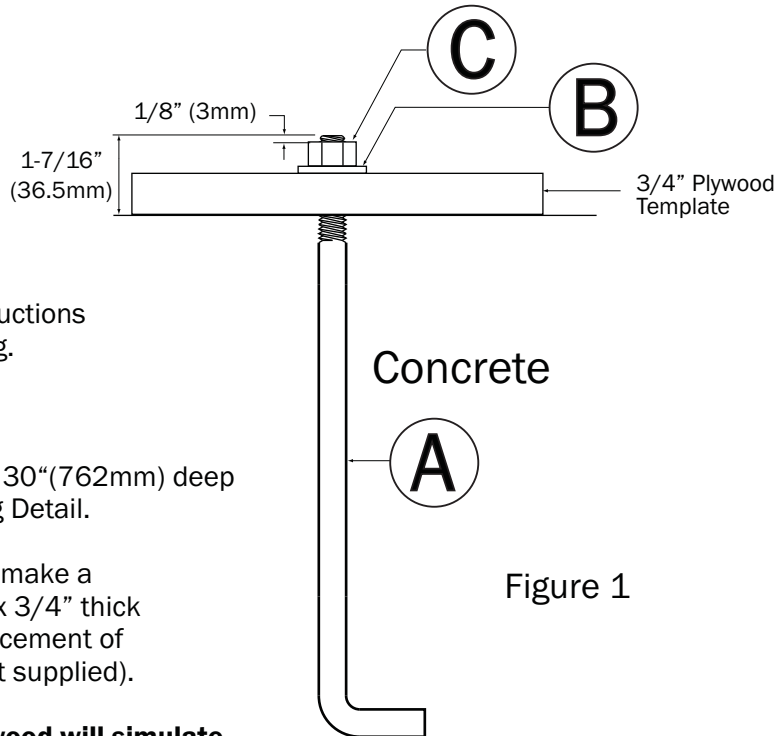



Figure 1

 Read all installation instructions thoroughly before starting.

Instructions:

1. Dig 30" (762mm) diameter x 30" (762mm) deep hole according to the Footing Detail.
2. Use the spring base plate to make a approx. 36" long x 36" wide x 3/4" thick plywood template for the placement of (4) Anchor Bolts (plywood not supplied).

NOTE: Thickness of plywood will simulate thickness of Base Plate until concrete has cured.

3. From center of plywood, mark (4) holes from Base Plate onto plywood and drill 1/2" thru holes.
4. Insert (4) 1/2" Anchor Bolts (A) into holes in plywood and secure with (4) Flat Washers (B) and (4) Hex Nuts (C).

 **Tighten Hex Nuts (C) onto Anchor Bolts until thread extends 1/8" beyond nut . (See Figure 1).**

5. Pour concrete footing and lay template on surface in a level position while forcing anchor bolts into concrete. Allow 72 hours of curing time before removing template.
6. After concrete has cured, loosen and remove Hex Nuts (C) and Flat Washers (B). Remove Plywood Template.
7. Align holes in Base Plate of Spring Rider with Anchor Bolts (A) in concrete.
8. Secure Spring Rider to concrete footer with (4) Flat Washers and (4) Hex Nuts.

DETAILS PAGE (In-ground Mounting Kit)

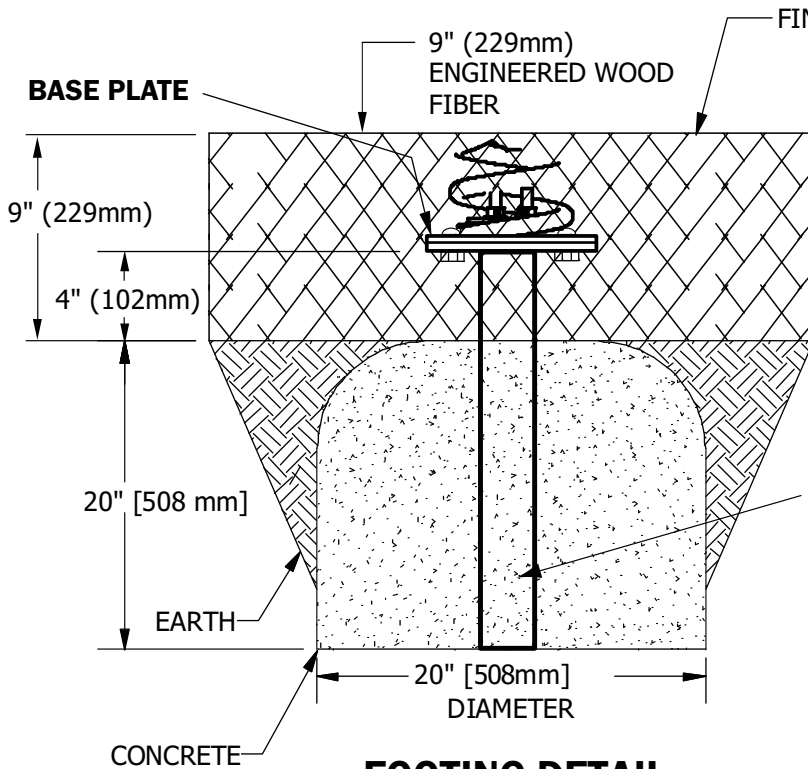

NOTE:

- Hole depths indicated on all ground plans are measured from the finished surface. See *Footing Detail*.

- All Footer dimensions are based on level finished surface.

Concrete Required :

Approx. .14 Cubic Yards (.1 Cubic Meters)
Suggested Min. concrete rating: 3000PSI

FOOTING DETAIL

USE ZONE: 12'(3658mm) x 19'(5791mm)

Top View

Note: Use zones can overlap for sitting type of equipment only if designated play surface height is 30"(762mm) or less.

Spring Riders and See Saw can be placed 6'(152mm) apart.

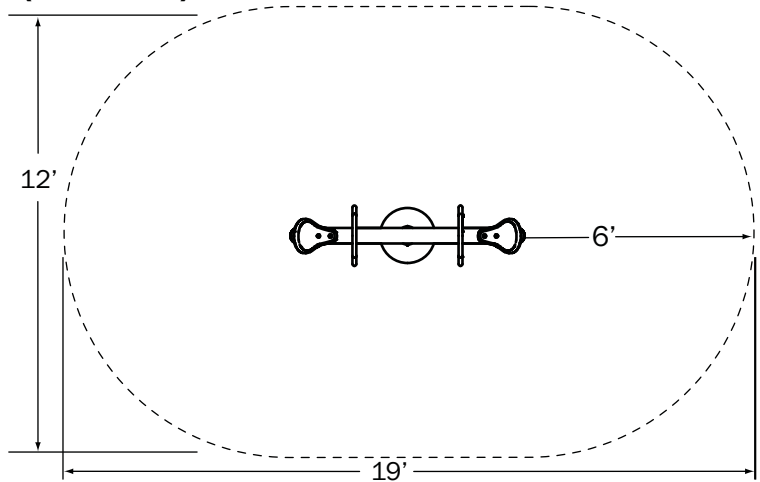



Specifications:

- Pipe Arm:** 5" Diameter(128mm) galvanized pipe, powder coated after fabrication.
- Handles/Foot Rests:** Formed from 1.0625(30mm) Galvanized Pipe, powder coated after fabrication.
- Spring:** Free height 13"(32mm), 6"(146mm) O.D. steel tempered, powder-coated.
- Seats:** Molded polyethylene
- Hardware:** Primary hardware is stainless steel.
- Base:** 3/16" thick steel plate, powder coated after fabrication.
- Wt:** 90lbs.

INSTRUCTIONS (In-ground Mounting Kit)

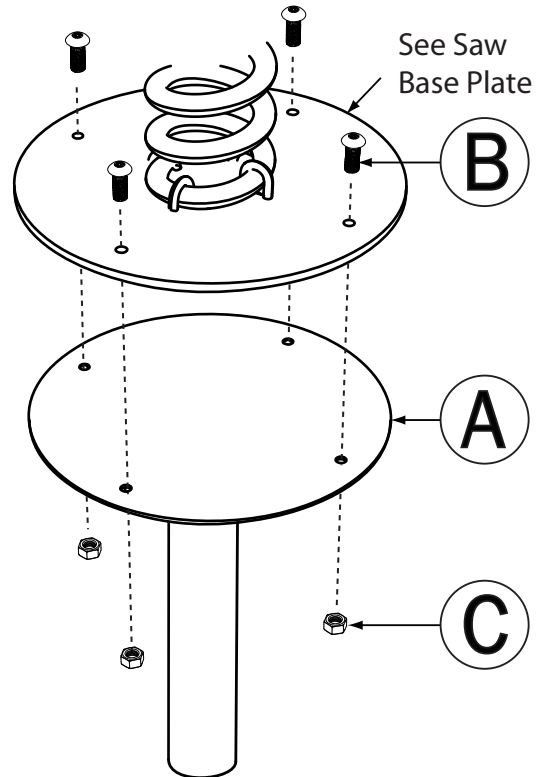
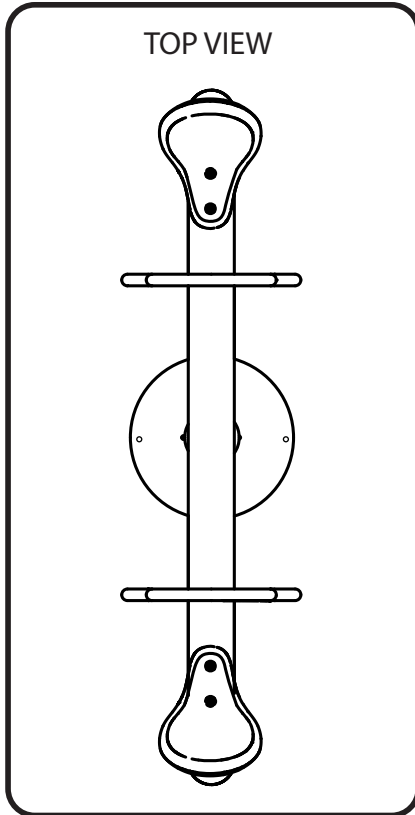
Parts List			
Letter	Description	Quantity	Part Number
A	In-ground Footer Post	1	G-02-07-0104
B	3/8" x 1-1/4" B.H.C.S. Bolt	4	33-05-0002
C	3/8" Hex Nut	4	33-01-0002



 Read all installation instructions thoroughly before starting.

Instructions:

1. Dig 20"(508mm) diameter x 20"(508mm) deep hole according to the Footing Detail.
2. Place In-ground Mounting Bracket(A) into center of hole and fill hole with concrete.
3. Level mounting plate. Allow 48 hours for concrete to cure before installing See Saw.
NOTE: In-ground footer plate may need to be supported while concrete cures.
4. Once concrete has cured, insert (4) 3/8"x 1-1/4" Bolts(B) into holes in See Saw Base Plate and into In-ground Mounting Bracket(A). Secure with (4) 3/8" Hex Nuts(C).