



Pond-free Instruction Manual

Includes Products:

PV1700

PV1800

PV2300

PV18EXT

PX23EXT

SP1600

SP1900

SP2600

SP3800

1.330.274.8317

www.ATLANTICWATERGARDENS.com

Table of Contents

Eco-blox vs. Gravel	Page 2
Streambed Construction	Page 3
Streambed Volume	Page 3
Basin Volume	Page 3

Pump Vault

Oasis Pump Vault Installation (PV1700)	Page 4
Excavating and setting the Pump Vault (Waterfall or Stream)	Page 4
Plumbing the Pump Vault (Waterfall or Stream)	Page 4
Excavating and setting the Pump Vault (Fountain)	Page 5
Plumbing the Pump Vault (Fountain)	Page 5
Excavating and setting the Pump Vault (PV1800/PV2300)	Page 6
Plumbing the Pump Vault (PV1800/PV2300)	Page 7

FastFalls

Setting the FastFalls (SP1600/1900/2600/3800)	Page 8
Liner and Plumbing Attachment	Page 8
Hiding the FastFalls	Page 9

Accessories

Triton Check Valve	Page 10
Discharge Pipe 'Perfect Cut' Reference Chart	Page 10
AF1000 Auto Fill	Page 11

Pond-Free

Pond-free features exchange the open water of the pond for a gravel-topped excavation, maximizing visual impact while minimizing headaches and maintenance. Typically, a pump placed in a protective vault inside a lined reservoir continuously recirculates water over a stream or waterfall. A bed of gravel hides the basin, vault and plumbing from view, leaving only the stream and waterfall visible.

ECO-BLOX vs. GRAVEL BASIN for a WATERFALL or STREAM

Eco-Blox basins consist of 10% Eco-Blox and 90% water. Gravel basins consist of 70% rock and only 30% water. As a rule of thumb, your pond-free basin should hold three times the amount of water as the waterfalls and streambeds above it. It is critical to calculate the water volume that the basin can hold before you begin construction of the waterfalls or streambed.

Why should the basin be three times the size of the stream? Upon start-up, the pump sends water from the bottom reservoir to the top of the waterfall and/or streambed.

The water must then fill, from top to bottom, the waterfall and streambed until it eventually re-enters the basin and the water levels equalize. During this filling process, the water level of the bottom reservoir is continually dropping.

If the streambed is built improperly, or is built too big, the water level of the bottom reservoir may drop below the top of the pump before the water levels equalize. This would result in the top of the pump being exposed to air. Pumps must be completely submersed in water or they can overheat causing damage to the pump.

STREAMBED CONSTRUCTION

Using proper streambed construction techniques can limit the transitional water needed to fill the streambed and enables the system to function optimally. Transitional water is determined by the height that the weir rock extends above the liner at the spillway opening. Maintaining the shortest distance possible between the top of the weir rock and the liner is a crucial component to a properly functioning water garden.

The drawings below displays two examples of proper construction techniques for minimal transitional water.

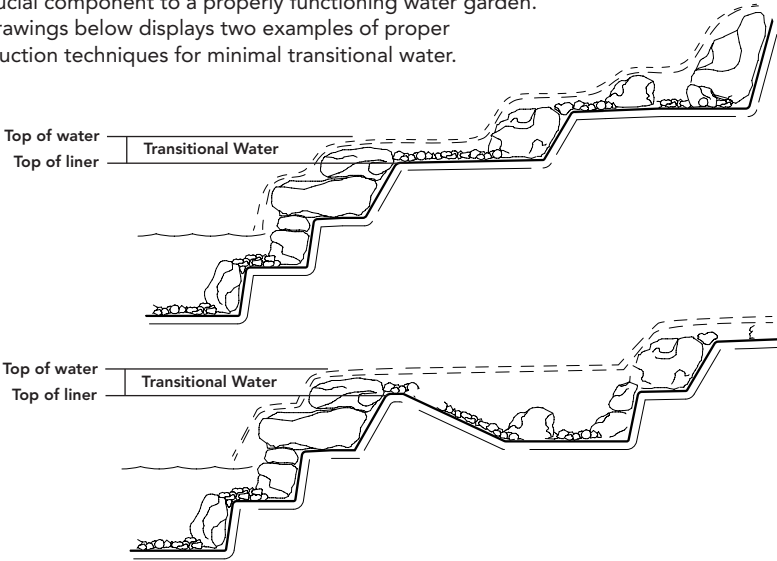

Below is an example of improper streambed construction. Stone, gravel and foam can be combined to make a barrier and create a waterfall, but that barrier will never be watertight. When the pump is turned off, the water will always drain down to the highest point of the liner. Improper construction greatly increases the water in transition.

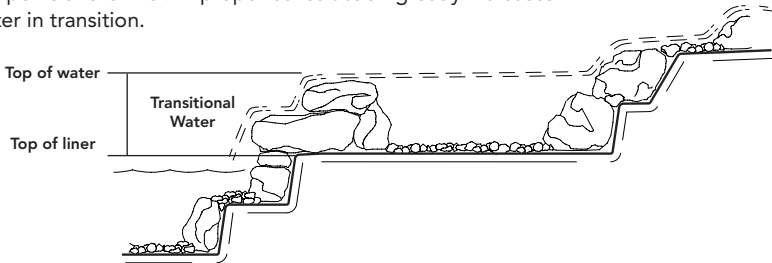

STREAMBED VOLUME

Multiply (in feet) the average length x the average width x the average depth to find cubic feet of streambed volume

2" DEEP = 0.16'

3" DEEP = 0.25'

4" DEEP = 0.33'

Don't forget that the thickness of your rocks will add extra depth to the water. (e.g. if you have rocks 1" deep covering the bottom of your stream, be sure to incorporate that 1" into your total depth)

BASIN VOLUME

For Eco-Blox: Multiply the cubic feet of the streambed x 3 = cubic feet needed for the basin
Cubic feet ÷ 4.2 = the number of Eco-Blox

For Gravel: Multiply the cubic feet of the streambed x 9 = cubic feet needed for the basin
Cubic feet ÷ 19 = the number of tons of gravel

Oasis Pump Vault Installation (PV1700)

The PV1700 is Atlantic's most compact, easy to install pump vault. The PV1700's features include an incredibly strong enclosure, recessed panels on the front that can accommodate Triton 3-Way Diverters, cut lines on the back for 1½" and 2" pump discharges, and marked drill points on the left and right sides for an Auto Fill.

EXCAVATING AND SETTING THE PUMP VAULT (WATERFALL or STREAM)

Once you have determined the proper size basin for your project, begin by deciding the placement of the vault. The vault should be placed away from the waterfall where the lid can be accessed easily.

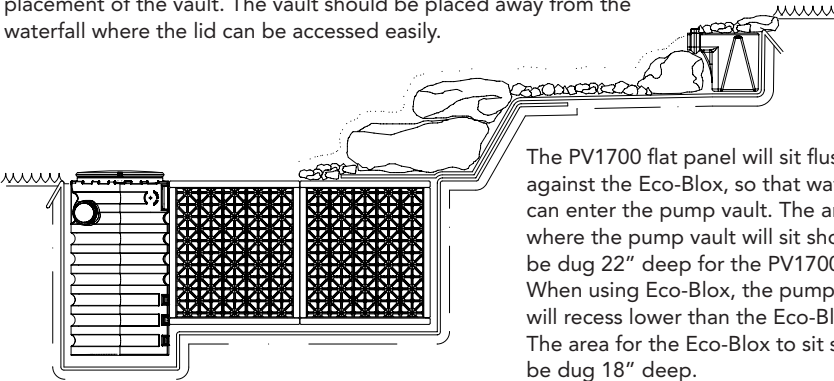

Once excavation is complete, install underlayment, pond liner, Eco-Blox and pump vault. Backfill the space between the Eco-Blox and the excavation to lock them into place, either outside the liner with sand or clean fill, or inside the liner with gravel ¾" or larger in diameter. Top the liner and basin with ¾" or larger gravel or decorative stone. Smaller, more decorative gravel, landscape glass, etc. can be used to cover the top of the basin, provided a denser mesh is installed beneath the material.

PLUMBING THE PUMP VAULT (WATERFALL or STREAM)

The PV1700 has pump discharge step fittings molded into each side of the enclosure. The step fittings are labeled for 1½" or 2" PVC pipe and have cut lines molded in for each size. This allows the installer the flexibility to exit out the left or right side. Use a hand saw to remove the appropriate step fitting, using the cut lines as a reference. The flat panel on the back is for an overflow. The two drill points near the top of the left and right sides are for the installation of an AF1000 Auto Fill (See Auto Fill instructions on pg. 11).

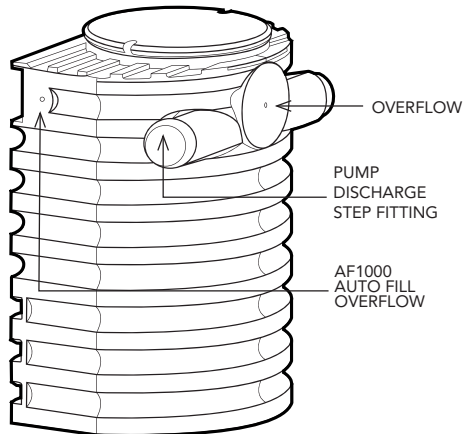

EXCAVATING AND SETTING THE PUMP VAULT (FOUNTAIN)

The capacity of the basin will vary depending on the size, height and number of the decorative fountain elements. For a general rule of thumb, make the basin at least twice the width of the fountain piece or fountain pieces at their widest point. To capture the splash from taller pieces or more aggressive flows, where added storage capacity isn't desired or needed, excavate a shallow 2-3" deep bowl around the basin and extend the liner out to at least twice the height of the decorative elements. This technique will recapture as much water as possible with minimum additional excavation. Consider increasing the storage capacity by incorporating Rainwater Harvesting into your design. For further information see our website www.atlanticwatergardens.com.

Once you have determined the approximate size of the basin, lay out the Eco-Blox and PV1700. The PV1700 should be placed away from the fountain piece where the lid can be accessed easily. Place the flat panel of the PV1700 up against the Eco-Blox so water can enter through the ports. Tailor the excavation to the shape of the Eco-Blox and PV1700 so the vertical walls of the basin will support the outside walls of the Eco-Blox, leaving a few extra inches all of the way around to make installation easier.

Dig the entire basin down to 20" below grade and carefully level the bottom of the excavation. This depth ensures the plumbing fittings exit out on top of the Eco-Blox. Install the underlayment and liner, then the Eco-Blox and PV1700.

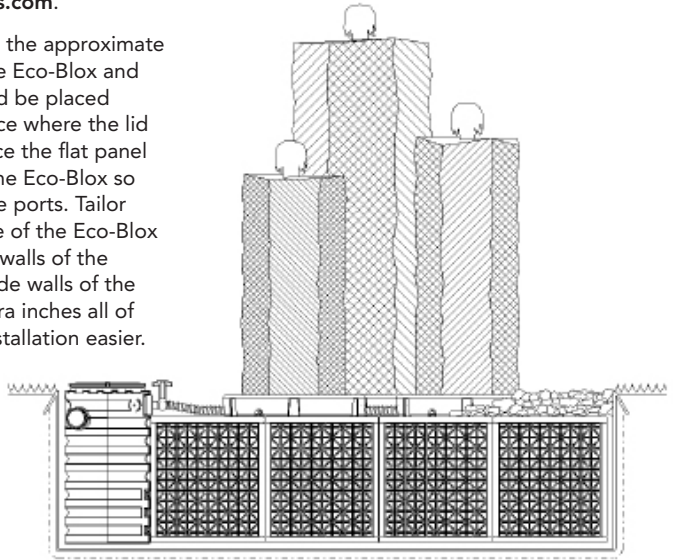

Backfill the space between the Eco-Blox and the excavation to lock them into place, either outside the liner with sand or clean fill, or inside the liner with gravel $\frac{3}{4}$ " or larger in diameter. Top the liner and basin with $\frac{3}{4}$ " or larger gravel or decorative stone. Smaller, more decorative gravel, landscape glass, etc. can be used to cover the top of the basin, provided a denser mesh is installed beneath the material.

PLUMBING THE PUMP VAULT (FOUNTAIN)

The recessed panels on the front right and left are designed to accommodate up to two optional Triton 3-Way Diverters, to allow plumbing and individual valving of up to six separately controlled decorative elements. To install, drill a $2\frac{1}{4}$ " hole with a hole saw (not included). The center point of the hole is marked on the panel.

The center raised area on the front of the PV1700 can be drilled for a single discharge of up to $1\frac{1}{2}$ " PVC pipe. Your pipe size will determine the size of the hole to drill. The flat panel on the back is designed to accommodate an overflow. The two drill points near the top of the left and right sides are for the installation of an Auto Fill (See Auto Fill instructions on pg. 11).

Pro Series Pump Vault Installation (PV1800/PV2300)

EXCAVATING AND SETTING THE PUMP VAULT

Once you have determined a proper sized basin for your project, begin by deciding the placement of the vault. The vault should be placed away from the waterfall where the lid can be accessed easily. Excavate the entire area of the basin to a depth of 18". This will accommodate one layer of Eco-Blox. The area where the pump vault will sit should be dug deeper to provide a sump area for the pump to sit, ensuring the pump will remain completely submersed. If using a PV1800, dig this area to a depth of 22", and for a PV2300, a depth of 28".

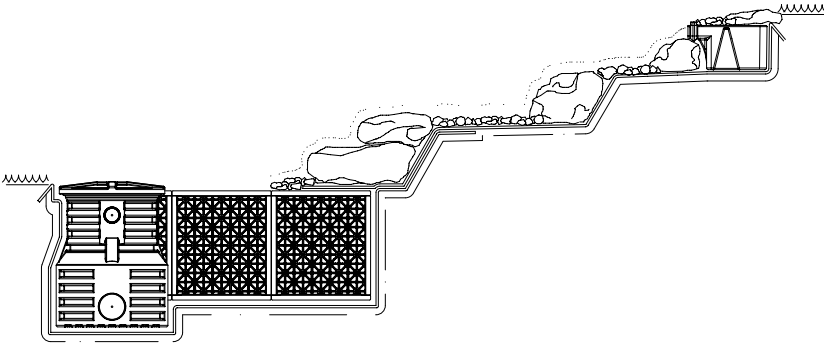

For installations where a larger basin volume or deeper basin is required, Atlantic offers pump vault extensions for both the PV1800 and PV2300. Each extension will add the height of one Eco-Blox. For each additional Eco-Blox layer, increase the depth of your excavation by 17".

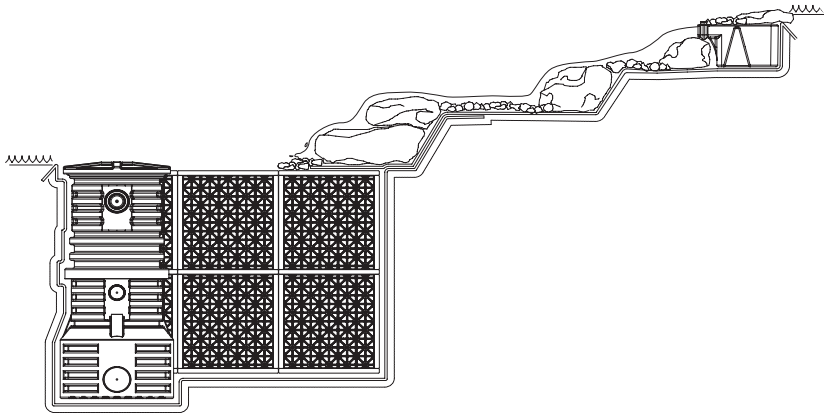

Once excavation is complete, install underlayment, pond liner, properly oriented Eco-Blox and Pump Vault. Backfill the space between the Eco-Blox/ Pump Vault and the excavation to lock them into place, either outside the liner with sand or clean fill, or inside the liner with gravel $\frac{3}{4}$ " or larger in diameter. Top the liner and basin with $\frac{3}{4}$ " or larger gravel or decorative stone.

PLUMBING THE PUMP VAULT

Atlantic's Pro Series Pump Vaults do not come pre-drilled for the pump outlet. Not having a pre-drilled pump outlet gives the professional installer the flexibility to choose which side of the enclosure to exit and with what size pipe. Drill points and cut lines have been provided for 2" and 3" flex PVC. Two panels at the top have been left flat for custom plumbing applications as well as the installation of an AF1000 Auto Fill and/or overflow. Recessed areas and cut lines for 4" and 6" SDR35 have been provided on two bottom panels. Pipe extensions can be added to increase the flow of water into the vault and also increase the ability to channel debris into the vault.

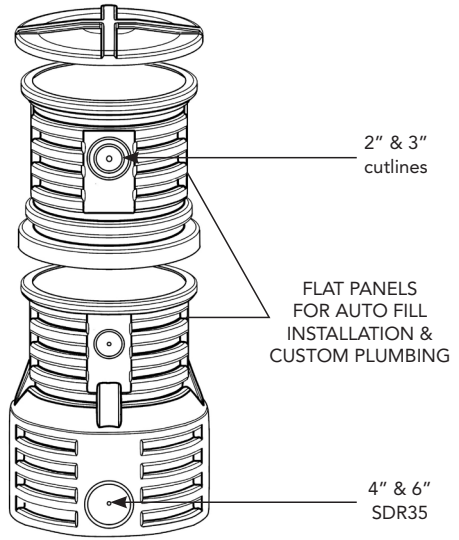

FastFalls Installation (SP1600/1900/2600/3800)

SETTING THE FASTFALLS

Place the FastFalls on a level bed of undisturbed soil if possible, to avoid settling. If installing above existing grade, compact the area thoroughly. This critical step will ensure that the FastFalls will not settle out of level over time. Blocks or bricks set on virgin soil can also be used to raise the FastFalls while reducing the chance of settling.

Place the FastFalls right at the basin's edge to create a single dramatic fall, or pull the FastFalls back from the edge to create a stream. Leave plenty of liner around the FastFalls to make it easy to camouflage with rock later.

To ensure a leak-proof installation, test place the FastFalls in the desired location and level it from side-to-side and front-to-back. The closed design of the FastFalls ensures that water will only exit the unit over the spillway, so there is no need to tilt the FastFalls forward.

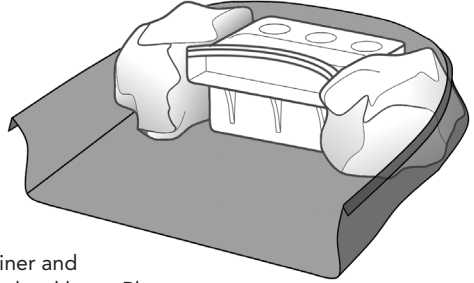

When you are satisfied with the placement of the FastFalls, remove the unit and install the liner and underlayment, being careful not to disturb the level base. Place the FastFalls on top of the liner in its original position. Check the unit for level to ensure that nothing has changed. Once the FastFalls is level and positioned correctly, place a couple of large stones on top of the FastFalls. This will ensure that the FastFalls does not move when backfilling and attaching liner.

LINER AND PLUMBING ATTACHMENT

Hold the liner up against the flat panel on the back of the FastFalls enclosure. Leave some excess slack in the liner below the spinweld. This will help alleviate any future strain on the liner connection. Make sure the back surface of the FastFalls, and the back side of the liner is clean and free of debris. Once you are satisfied with the position of the liner, lower it down and prepare to apply the silicone sealant.

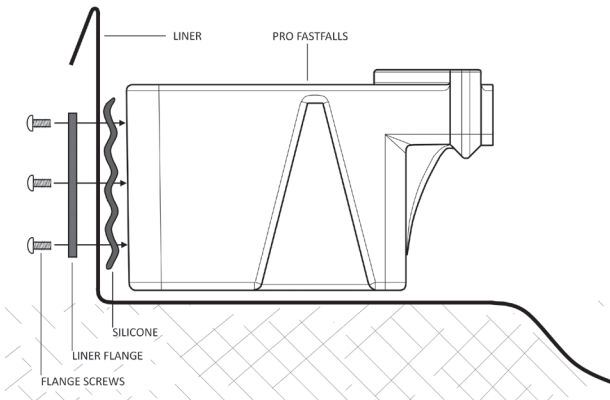

Apply Atlantic's Silicone Sealant in a continuous, consistent bead along the center of the threaded inserts. Once completed, return the liner to its dry-fit position.

Attach the supplied flange to the FastFalls, starting with the top screw first, working around the flange. If needed, use an awl or nail to pierce the liner before inserting the screws. Do not fully tighten any screws until all of the screws have been installed. Once completed, trim away the liner on the inside of the flange to expose the threaded inlet.

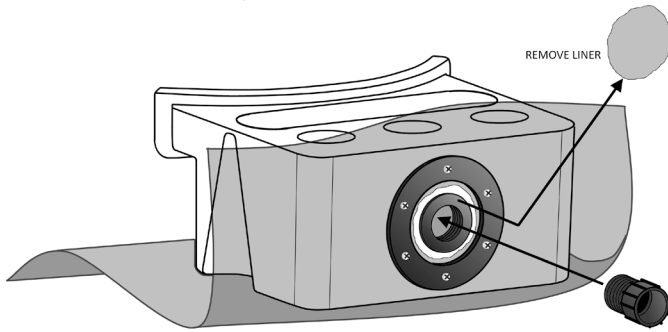

Tighten flange screws with a hand held screwdriver only. Over tightening the screws could strip out the inserts or crack the liner flange. The screws need only to be snug for the silicone to make a seal.

Apply silicone on the threads of the Male Thread Adaptor (MTA). Screw the MTA into the spinweld until tight. Use PVC Glue (not included) to glue the PVC flex hose into the MTA.

HIDING THE FASTFALLS

Position rocks on either side of the FastFalls, inside the liner. Start working the rock in and around the front of the FastFalls, building up to the lip of the FastFalls, which will provide support for a lip rock. The Fastfalls will support the weight of gravel and rocks, stacked directly on top of the unit. The FastFalls easily supports the weight, so consider covering the whole unit with a single size-able overhanging capstone, or stack individual smaller stones and gravel on top to completely conceal the FastFalls. For a 'grown-in' look, cover the FastFalls with soil and plant small evergreens and perennials right on top. The raised lip will keep the gravel or soil from washing into the water.

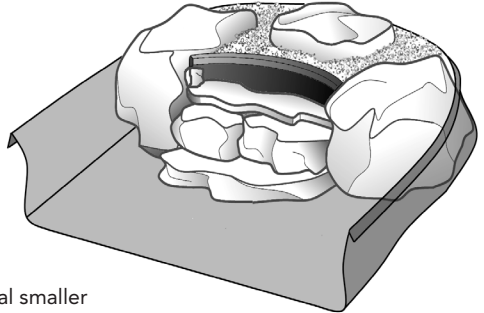

Accessories

TRITON CHECK VALVE

Locate the model number of the Atlantic Pump Vault and TidalWave pump used for this installation on the chart on the next page. Follow the corresponding column down and row across until they intersect. The number or letter at the intersection point is the 'perfect cut' reference mark for this installation. If the corresponding reference mark is a letter, then the 1½" threaded end of the discharge pipe will be used. If the corresponding reference mark is a number, then the 2" threaded end of the discharge pipe will be used.

DISCHARGE PIPE 'PERFECT CUT' REFERENCE CHART

Shaded areas denote pumps that exceed maximum flow rates or dimension for use with the corresponding Pump Vault. Use of this equipment combination is not recommended and could void the warranty.

* The discharge pipe can be extended with the 2" PVC pipe and a coupling for use with Pump Vaults extensions.

Locate the correct reference mark for this installation on the discharge pipe. Using a hacksaw or PVC saw, cut the pipe at this mark being careful to make a clean, square cut. Discard the end of the discharge pipe that will not be used.

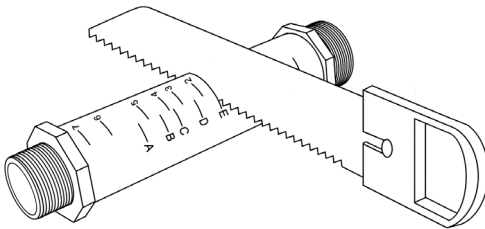

Use a small piece of sandpaper to smooth out the cut end of the discharge pipe. Clean the 2" socket fitting on the bottom of the check valve and the cut end of the discharge pipe with PVC cleaner/primer. Apply PVC glue and insert the discharge pipe into the 2" socket fitting. Hold the discharge pipe firmly in place for a few seconds, giving the glue time to set.

	PV1700	PV1800	PV2300
TT1500	B	B	H
TT2000	B	B	H
TT3000	B	B	H
TT4000	B	B	H
TT5000	0	0	5
TT6000	0	0	5
TT9000	N/A	0	4
TW1200	B	B	G
TW1900	B	B	G
TW2400	B	B	G
TW3700	A	A	F
TW4800	A	A	F
TW6000	1	1	5
SH1450	E	E	I
SH2050	E	E	I
SH3600	E	E	I
SH5000	C	C	H
SH6500	C	C	H
PAF-20	3	3	7
PAF-25	3	3	7
PAF-40	3	3	7
PAF-75	3	3	7
A-05	3	3	7
A-05L	2	2	6
A-21	2	2	6

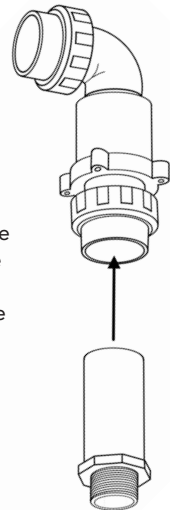

Attach the Triton Check Valve to the TidalWave pump by threading the discharge pipe into the pump discharge.

Place the TidalWave pump with installed Triton Check Valve into the Pump Vault. Connect the outlet fitting of the Triton Check Valve to the PVC supply line that feeds the waterfall using PVC glue and cleaner. For your convenience; 2" and 1½" outlet fittings are supplied with the Triton Check Valve.

Complete installation by tightening the union nuts on the Triton Check Valve. Hand tighten only. Do not use channel locks to tighten the union nuts.

AF1000 AUTO FILL KIT

Drill points or flat areas have been provided for the proper Auto Fill location on either side of the Pump Vault. It is a good idea to completely install the pump, check valve assembly, and discharge hose before you drill for the Auto Fill. This will help you determine the best side of the Skimmer or Pump Vault to place the Auto Fill so that it has proper clearance on all sides. The center point of the Auto Fill should be located approximately 1½ to 2" above the normal operating water level of the basin.

Once you have determined the location of the Auto Fill, drill a 7/8" hole using a spade bit or hole saw. Insert the Auto Fill, making sure the gasket is on the water side of the unit, and the plastic retaining nut is on the outside. Thread the retaining nut onto the Auto Fill Valve, being careful not to over-tighten.

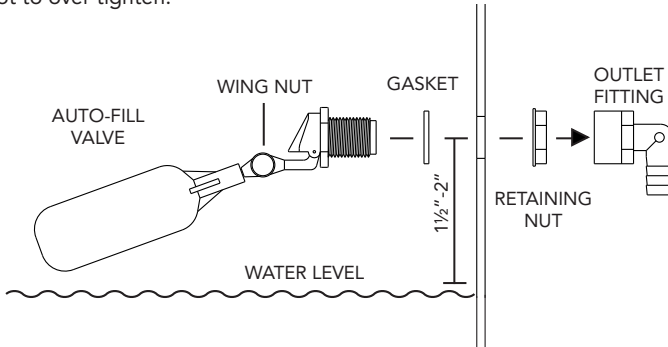

The Auto Fill Kit includes fittings for connection to a garden hose, ½" irrigation line, and ½" Sch 40 PVC. Wrap the ½" male threads on the Auto Fill with thread sealant and install the fitting of your choice. Once water is supplied to the Auto Fill it will maintain the set water level by automatically adding water when the level drops. This level can be adjusted by loosening the wing nut and raising and lowering the height of the Auto Fill float.

Flow Rate: 0.5 to 1.5 gpm / Inlet Pressure: 80 psi max



1.330.274.8317

www.ATLANTICWATERGARDENS.com