

Mini Aeration System

Aeration

Matala®
"Make water alive"

MEA Pro Mini 2000

Pond Aeration is now easier than ever!



INSTALLATION INSTRUCTIONS



Features and benefits:

- Breathe life into your pond !
- Reduce algae growth and sludge build up.
- De-ice to prevent winter fish kill.
- Self-weighted disc with low back pressure and durable material.
- Silicone material surface of self-weighted disc.
- Simple maintenance.
- Simple replacement.
- Silent operation.
- Long life expectancy.
- Improve fish health.
- High efficiency and capacity.

WARRANTY

Limited Warranty:

Matala will repair or replace for the original owner any portion of a new MEA Pro Mini 2000 Air Pump only (warranty does not include replacement the diaphragm set, air hose, check valves or air filter) which proves defective due to materials or workmanship within 3 year of purchase date. Warranty period for the silicone membrane diffuser discs is 1 year of purchase date. Proof of purchase required. Please keep a copy of the original sales receipt in the event of a warranty claim.

Contact the nearest authorized dealer for warranty service.

Matala shall possess the sole right to determine whether to repair or replace defective equipment, parts or components.

When the air pump is losing air pressure, it is recommended to replace the air diaphragm and can be obtained from an Authorized Distributor.

THIS WARRANTY DOES NOT COVER DAMAGE DUE TO LIGHTNING OR OTHER CONDITIONS BEYOND THE CONTROL OF Mini Air Pump.

THE WARRANTY WILL NOT APPLY:

- (a) to defects or malfunctions resulting from failure to properly install, operate, or maintain the unit in accordance with printed instructions provided.
- (b) to failures resulting from abuse, accident, or negligence.
- (c) to normal maintenance services and the parts used in connection with such service such as the diaphragm set, air hose, check valves and air filter.
- (d) to units which are not installed in accordance with applicable local codes, ordinances, and good trade practices.
- (e) if unit is used for purposes other than for what it was designed and manufactured for.
- (f) if unit or components have been tampered with or modified in any way by an unauthorized dealer or repair shop.

INSTALLATION INSTRUCTIONS

Step 1 The pump should be placed indoors and in a stable place. The location should be dry and less dust, and can not be soaked.

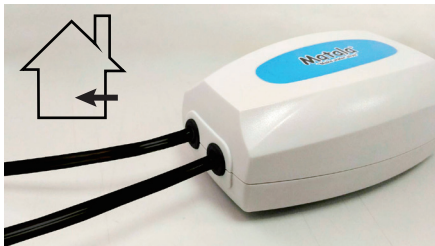

Step 2 Connect the air hoses to the outlets of the MEA Pro Mini 2000. Make sure the air hose is not twisted or kinked.



Step 3 Install the check valves between the air pump and the diffusers. Make sure the arrow on the check valve is pointing to the diffuser discs.

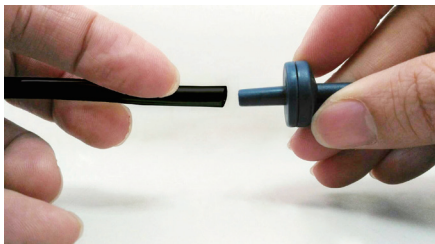

Step 4 Plug into the power 110~120V GFCI protected outlet. Do not use extension cords.



Notice Failure to plug unit into GFCI outlet and/or improper location of air pump will void warranty.

PRODUCT CONTENTS

Model:MEA Pro Mini 2000

NO.	DESCRIPTION	SPEC	Q'TY
1	Air pump	0.34CFM	1
2	Air hose	ØID5/32inchx30ft ØID4mmx9m	2
3	Check valve	—	2
4	Diffuser disc	MD-3W (3.5")	2

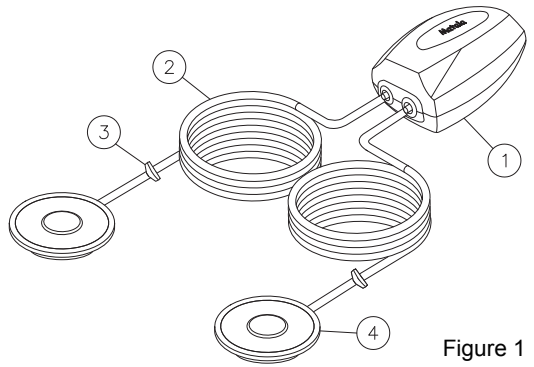
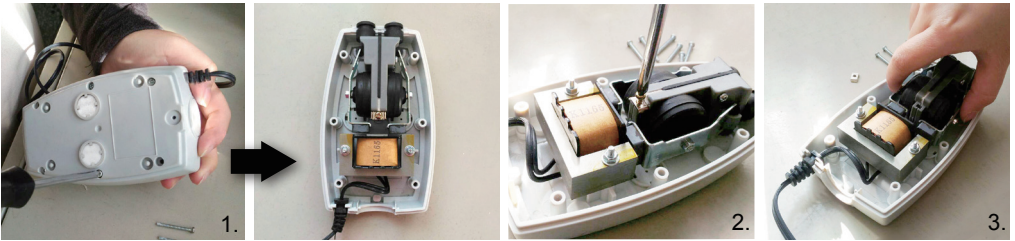

Figure 1

OPERATION AND MAINTENANCE

When the air pressure drops(wear and tear), change the diaphragm set to bring the air pump back to work. It is recommended to change the diaphragm set once per year to maintain optimal flow. Be sure to unplug the power before doing the replacement.(Figure 2)

1. Remove the six screws(item no.12) located at the bottom and open the pump cover(item no.1).
2. Remove the screw(item no.10) and holding plate(item no.11) that secure the diaphragm set(item no.6) to the base.
3. Installing the new diaphragm set, and reassemble all parts by reversed orders.



Notice: Don't place the diffuser disc at the bottom of the pond in winter. The fish are overwintering in the deeper portions of the pond. Instead, place the diffuser about 1 to 1-1/2ft below the water surface.

ITEM	DESCRIPTION	Q'TY
1	Pump cover	1
2	Plug	1
3	Electromagnet	1
4	Power cord	1
5	Bushing	2
6	Diaphragm set	1
7	Base	1
8	Rubber feet	4
9	Filter	2
10	Screw (diaphragm set)	1
11	Holding plate	1
12	Screw (housing)	6

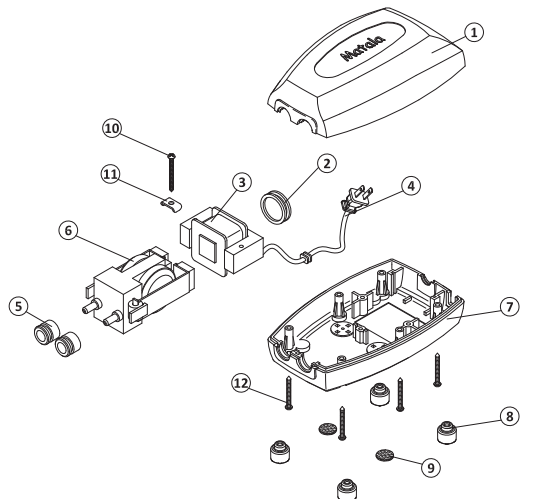

Figure 2

MEA Pro Mini 2000

Pond Aeration is now easier than ever!

SPECIFICATIONS

Mini Aeration System

Specification	Item	MEA Pro Mini 2000
Max flow	(cfm) / (lpm)	0.34 / 9.5
Rated voltage	(V)	110~120V
Power supply frequency	(Hz)	50 / 60
Closed pressure	(psi) / (bar)	3.1 / 0.21
Power	(W)	6W
Outlet		2 ways
Maximum air depth		8.5ft
Suggested pond size		Up to 2,000 gallons
Silicone membrane diffuser discs		MD-3W (3.5") x2 pcs
Air hose		ØID5/32inchx30ftx2rolls / ØID4mmx9mx2rolls
Check valve		2 pcs
Mini air pump dimensions: LxWxH	(inch) / (mm)	5.9x3.5x2.4 inch / 148x90x65 mm
G.W.	(lbs) / (kg)	4.4 / 2.0

* The above specification are subject to change without prior notice.

TROUBLESHOOTING

Problems	Possible Cause	Remedy
Loss of airflow	Check valves	Arrow pointing in the direction of the air flow
	Air hose	Not kinked, restricted, leaks or clogging
	Diaphragm set	Replace
	Air filter	Replace or clean

DISTRIBUTED BY



161118

Matala[®]
"Make water alive"

MATALA WATER TECHNOLOGY CO., LTD.
www.matala.com.tw

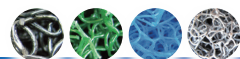

Think Progressive !