

Black 60" x 24" Table Top

Instruction Manual

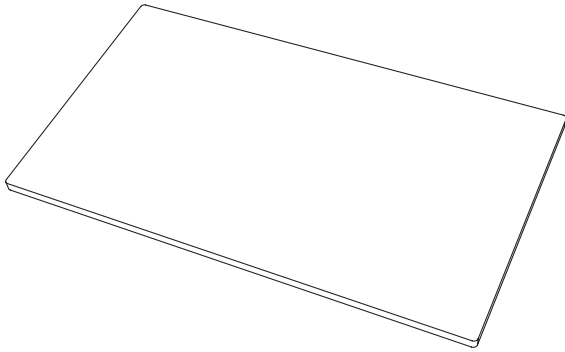

SKU: DESK-TOP60B



Scan the QR code with your mobile device or follow the link for helpful videos and specifications related to this product.

<https://vivo-us.com/products/desk-top60b>



help@vivo-us.com



www.vivo-us.com



309-278-5303

WARNING!

If you do not understand these directions, or if you have any doubts about the safety of the installation, please call a qualified technician. Check carefully to make sure there are no missing or defective parts. Improper installation may cause damage or serious injury. Do not use this product for any purpose that is not explicitly specified in this manual and do not exceed weight capacity. We cannot be liable for damage or injury caused by improper mounting, incorrect assembly, or inappropriate use.

PACKAGE CONTENTS

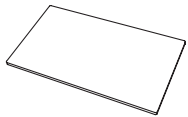

A (x1)
Desktop

TOOLS NEEDED



Drill



**Phillips
Screwdriver**

ASSEMBLY STEPS

STEP 1

Mount the desktop to the desk frame using screws. If necessary, drill pilot holes for the screws to match your desk frame.



Please note that mounting screws are not included with this desktop. Use the mounting hardware included with your standing desk frame to mount the desktop.

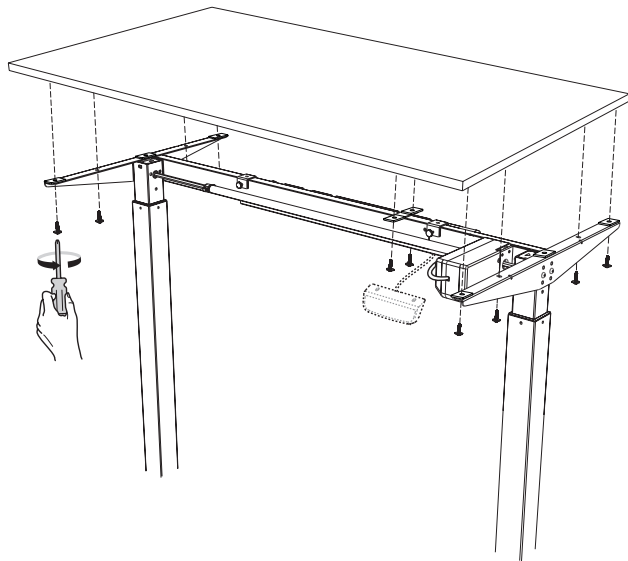

This desktop is pre-drilled to match the mounting holes in most VIVO electric desk frames with two legs. Please note that holes for a controller are not pre-drilled, as the controller location is determined by user preference.

STEP 2

Use a bubble level to make sure the desktop is level. If necessary, adjust the foot pads on the standing desk frame to level the desktop.

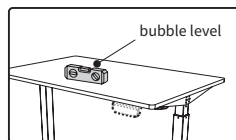
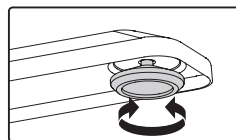

STEP 3

If installed to an electric height adjustable desk frame, the desk may now be plugged into a power outlet.

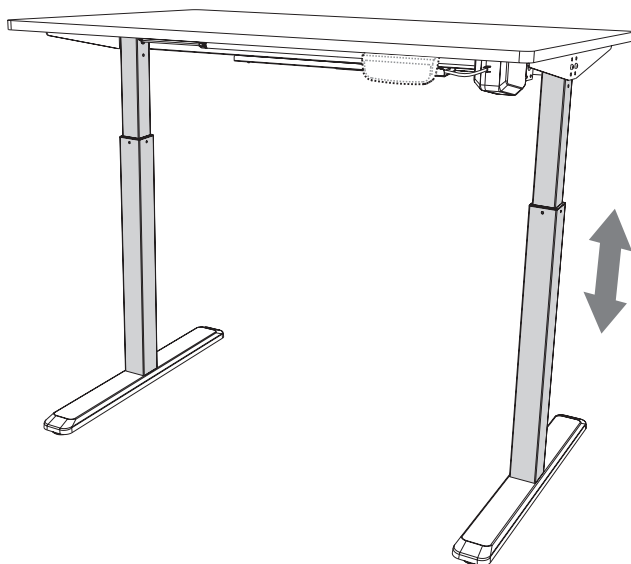
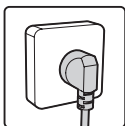



Love your new VIVO setup and want to share?

Tag us in your photo! [@vivo_us](#)

LAST UPDATED: 09/13/2019



Open **Monday-Friday from 7:00am-7:00pm CST**,
our dedicated support team can offer immediate assistance with rapid response times.
If any parts are received damaged or defective, please contact us.
We are happy to replace parts to ensure you have a fully functioning product.



help@vivo-us.com

AVG. RESPONSE TIME (*within office hrs*): **1HR 8M**

- 23% within < 15m
- 38% within < 30m
- 61% within < 1hr
- 83% within < 2hr
- 92% within < 3hr



www.vivo-us.com

AVG. RESOLUTION TIME (*within office hrs*): **< 15 M**



309-278-5303

AVG. RESOLUTION TIME (*within office hrs*): **5M 4S**

FOR MORE VIVO PRODUCTS, CHECK OUT OUR WEBSITE AT: www.vivo-us.com