

---

## Triple Monitor Mount

### Instruction Manual

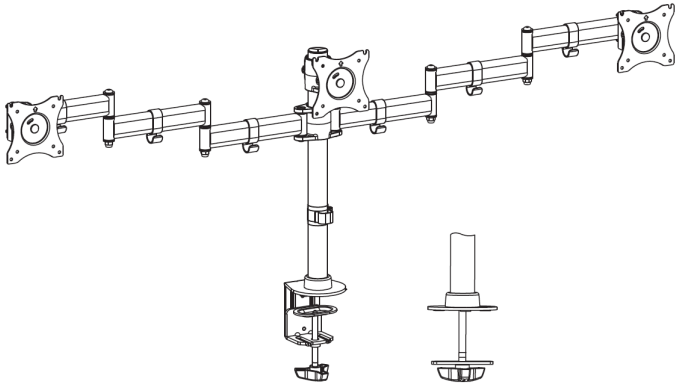

**SKU: STAND-V003M**



Scan the QR code with your mobile device or follow the link for helpful videos and specifications related to this product.

<https://vivo-us.com/products/stand-v003m>



help@vivo-us.com



www.vivo-us.com



1-800-371-5654

**WARNING!**

If you do not understand these directions, or if you have any doubts about the safety of the installation, please call a qualified technician. Check carefully to make sure there are no missing or defective parts. Improper installation may cause damage or serious injury. Do not use this product for any purpose that is not explicitly specified in this manual. Do not exceed weight capacity. We cannot be liable for damage or injury caused by improper mounting, incorrect assembly or inappropriate use.

**TIPOVER WARNING**

SERIOUS OR FATAL CRUSHING INJURIES CAN OCCUR FROM TIPOVER. TO HELP PREVENT TIPOVER:

- NEVER ALLOW CHILDREN TO CLIMB, STAND, HANG, OR PLAY ON ANY PART OF MONITOR OR STAND.
- USE TIPOVER RESTRAINT OR ANCHOR STAND TO WALL

USE OF TIPOVER RESTRAINTS MAY ONLY REDUCE, BUT NOT ELIMINATE RISK OF TIPOVER.

**WARNING: CHOKING HAZARD**

SMALL PARTS - NOT FOR CHILDREN UNDER 3 YEARS. ADULT SUPERVISION IS REQUIRED.

**PACKAGE CONTENTS**

<b>A (x1)</b> Arm	<b>B (x1)</b> Pole	<b>C (x1)</b> VESA Bracket	<b>D (x1)</b> C-Clamp
<b>E (x1)</b> Grommet Plate	<b>F (x6)</b> Cable Clip	<b>G (x1)</b> Cable Clip	<b>H (x1)</b> Base Cover
<b>I (x5)</b> Soft Pad	<b>J (x1)</b> Support Plate	<b>K (x1)</b> 3mm Allen Wrench	<b>L (x1)</b> 5mm Allen Wrench
<b>M (x1)</b> 6mm Allen Wrench	<b>M-A (x12)</b> M4x12	<b>M-B (x12)</b> M5x12	<b>M-C (x12)</b> D5 Washer

NOTE: NOT ALL HARDWARE INCLUDED WILL BE USED

**TOOLS NEEDED**



DO NOT EXCEED WEIGHT CAPACITY.  
Failure to do so may result in serious injury.

**17.6 lbs  
Per Arm  
(7.98 kg)**

**ASSEMBLY STEPS**

**STEP 1**

**OPTION A: Clamp Installation**

Stick soft pads (I) to bottom of clamp base (D). Slide cable management clip (G) and base cover (H) on to bottom of pole (B). Thread pole (B) onto clamp (D). Tighten grub screws in bottom of clamp (D) using 3mm allen wrench (K). Secure clamp (D) to desktop as shown in diagram.

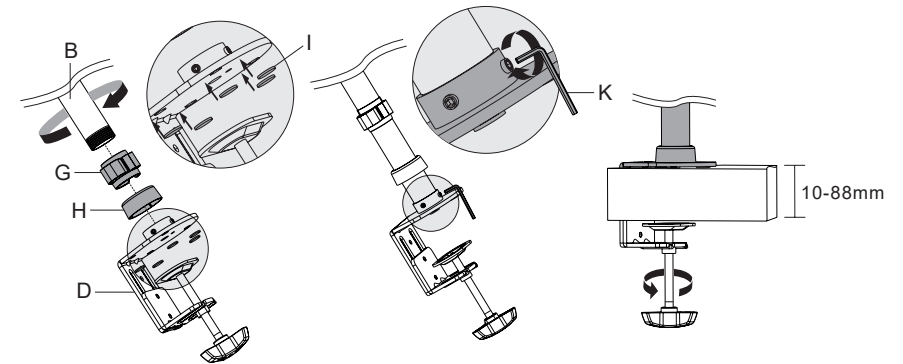

**OPTION B: Grommet Base Installation**

Remove screw from top of bolt in clamp (D). Stick soft pads (I) to bottom of grommet base (E). Slide cable management clip (G) and base cover (H) on to bottom pole (B). Thread bottom pole (B) onto grommet base (E). Tighten grub screws in bottom of grommet base (E) using 3mm allen wrench (K). Slide metal pad (J) over bolt and slide through grommet hole in bottom of desktop. Thread into bottom of pole (B).

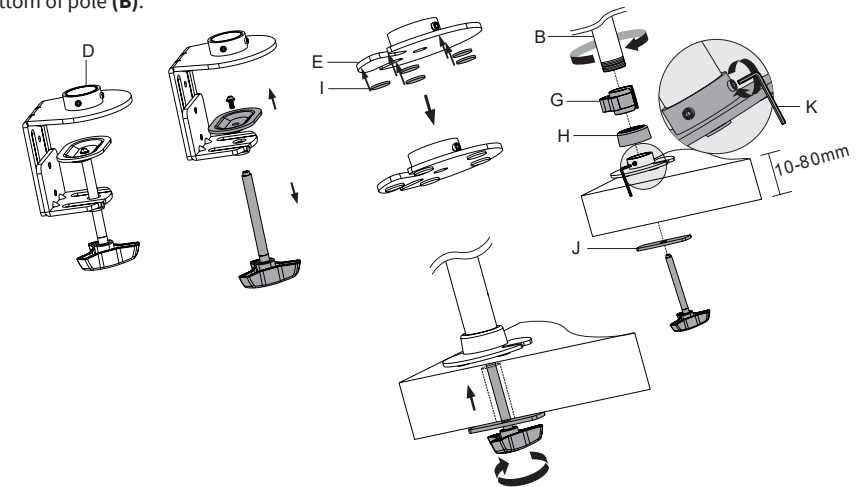

## STEP 2

Slide arm (A) and bracket (C) over top of pole and tighten using 5mm allen wrench (L).

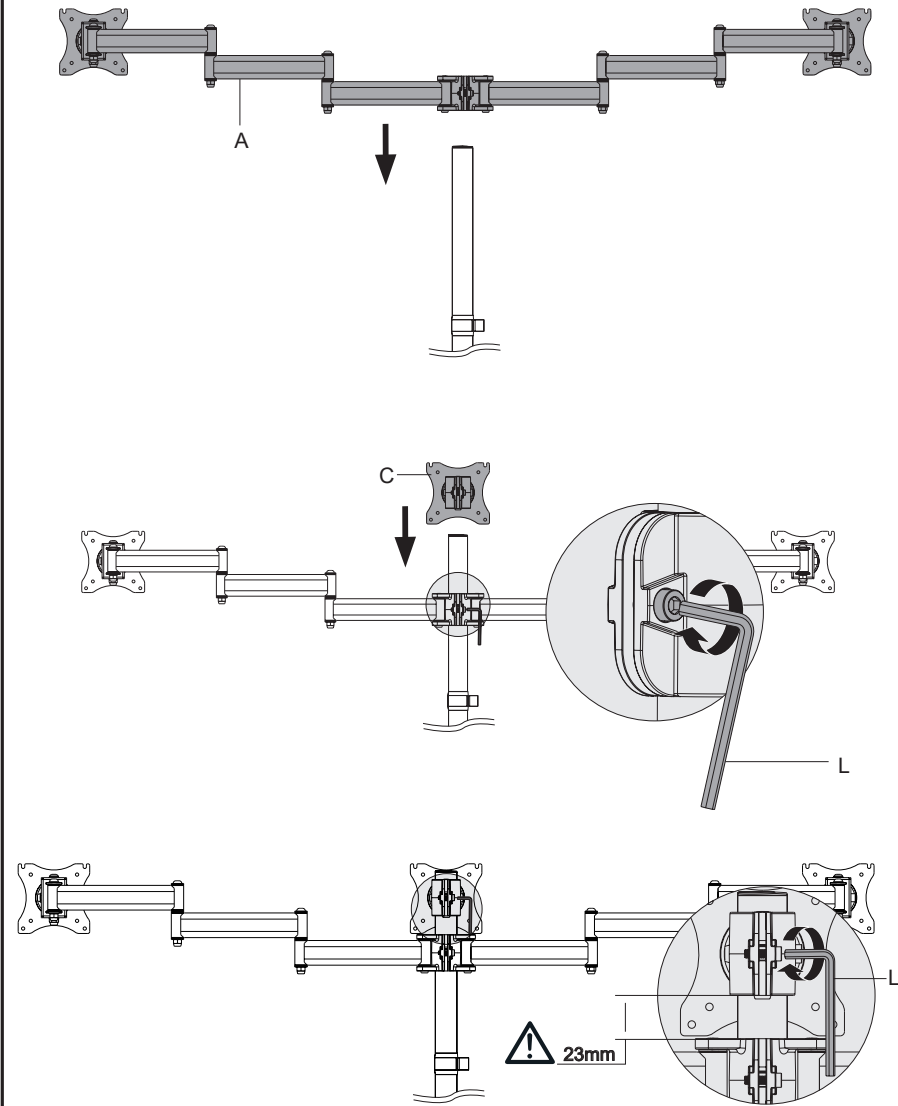

## STEP 3

Attach cable management clips (F) as shown in diagram.

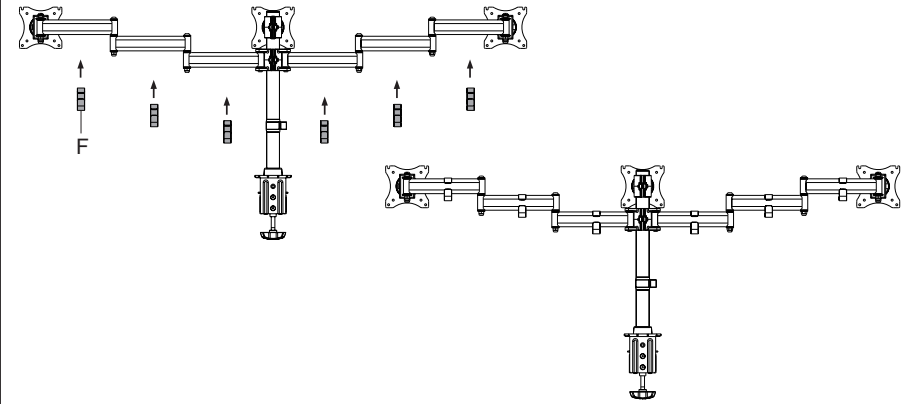

## STEP 4

Attach two bolts (M-A or M-B) and washers (M-C) to top mounting holes of monitor, making sure to leave 3mm of threads exposed. Align bolts (M-A or M-B) in VESA plate. Secure using two more bolts (M-A or M-B) and washers (M-C) in the bottom two holes. Tighten all four bolts using phillips screwdriver.

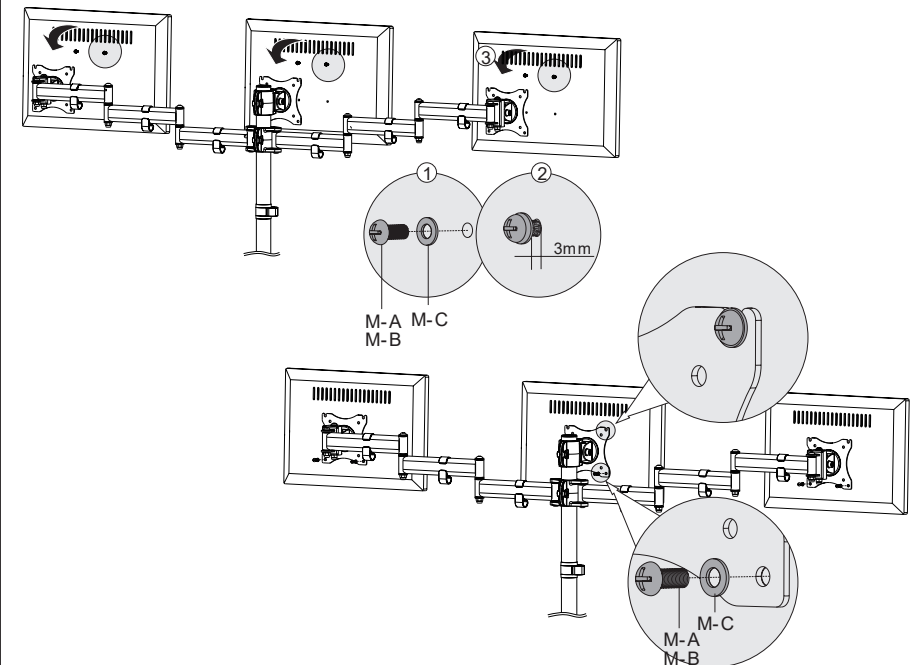

### STEP 5

Adjust tension in monitor bracket with 6mm allen wrench (**M**) as shown in diagram.

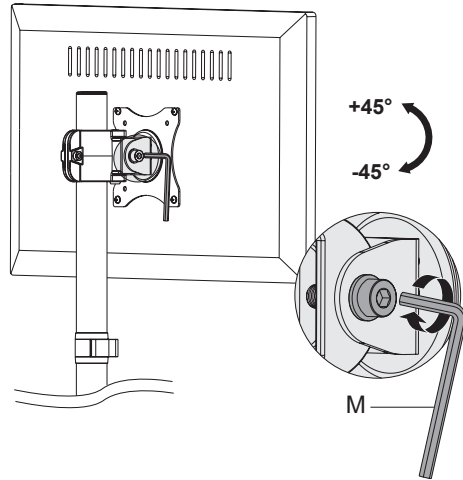

### STEP 6

Store allen wrenches (**M, L**) in cable management clip (**G**) for future adjustment.

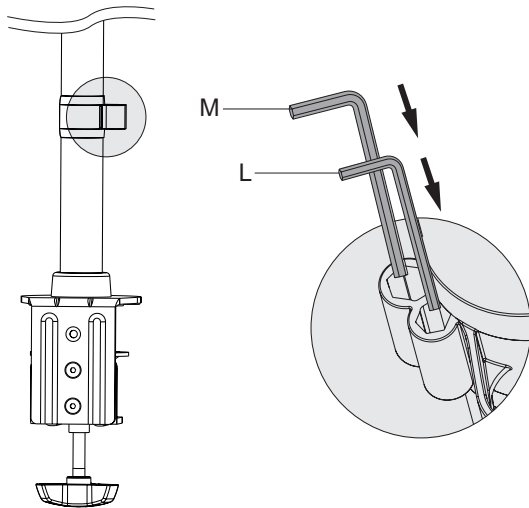

### STEP 7

Adjust height of monitors using 5mm allen wrench (**L**) as shown in diagram.

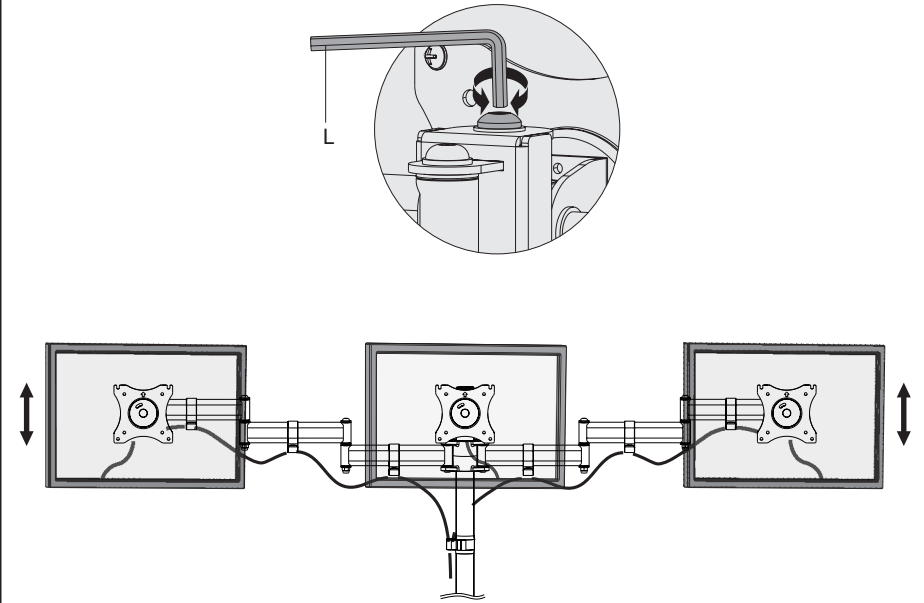



Love your new VIVO setup and want to share?

Tag us in your photo! **@vivo\_us**

Last Updated: 11/06/2018



If any parts are received damaged or defective, please contact us. We are happy to replace parts to ensure you have a fully functioning product.



[help@vivo-us.com](mailto:help@vivo-us.com)



[www.vivo-us.com](http://www.vivo-us.com)



1-800-371-5654

For more VIVO products, check out our website at:  
[www.vivo-us.com](http://www.vivo-us.com).