

# 316 Stainless Steel Flush Cup Holder with No Hose Barb

PN# S-3511AV

## INSTALLATION INSTRUCTIONS:

- 1: Mark the center of the cut out hole for drilling with a pencil.
- 2: Drill 3-5/8" hole through the mounting surface using the drill hole bit (Figure.1)
- 3: Place cup holder into the whole to ensure it fits. Adjust the hole size if needed.

Note: Ensure that the surface you are cutting into is atleast 3-1/8" thick. (Figure.2)

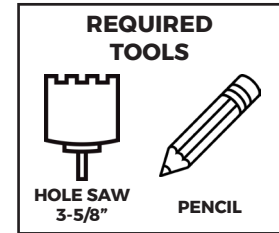

FIGURE.1

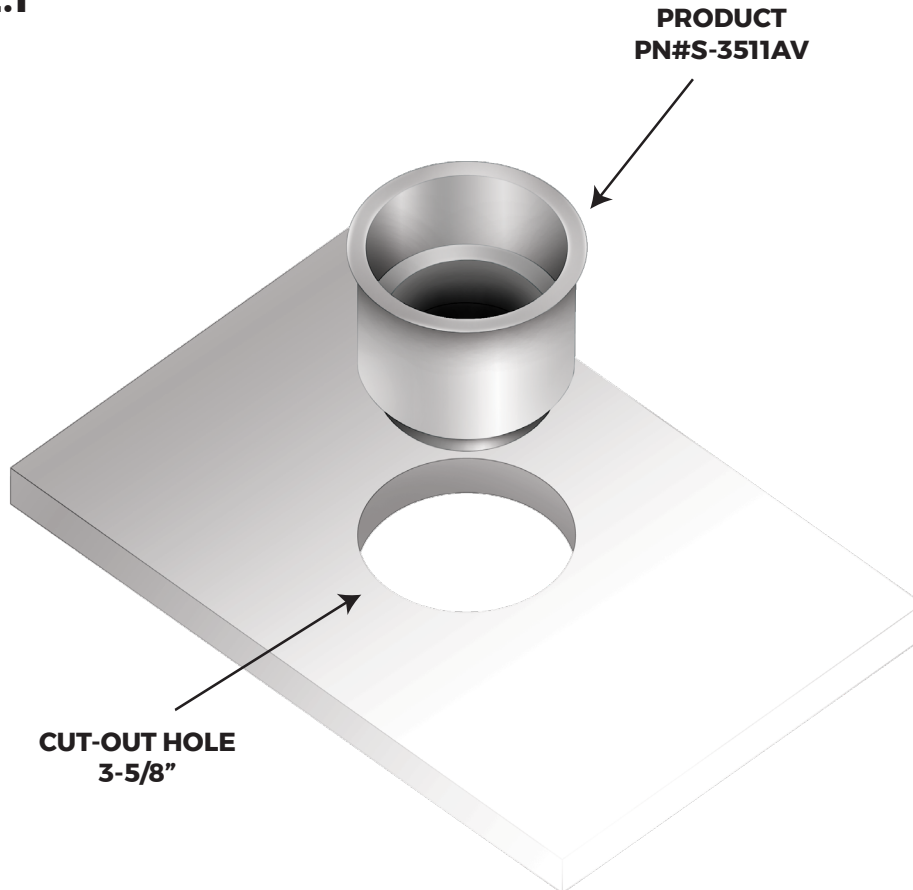

FIGURE.2

